



INSTALLATION INSTRUCTIONS

Locking rear storage compartment assembly #143

Please read and fill out the enclosed warranty registration card to activate your warranty.

Shipment Contents

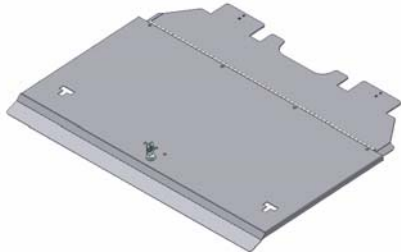

Main lid assembly



#7 (2) Clamps



#1 Lock bracket

Shipping Package



#8.1 (2) 5/16-18x1 1/4" Screw



#8.4 (4) 10-32x1/2 Screw

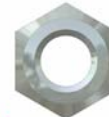

#8.3(2) 5/16 Nuts



#8.2 (2) 5/16 Washers



#8.5 (4) #10 Washers

TOOLS NEEDED

- 1/8" Allen Wrench
- Ratchet, 1/2" socket and 1/2" Wrench

PLEASE READ ALL INSTRUCTIONS THOROUGHLY BEFORE STARTING INSTALLATION.

1. Insert the #1 Lock bracket under the flanges in the jack storage compartment with the main flat surface on the lock bracket against the side of the storage compartment. (See Figure 1)
2. Using the (2) 5/16x1 1/4 bolts #8.1, (2) 5/16 washers #8.2, and (2) #8.3 nuts fasten both #7 clamps to the #1 lock bracket. This should sandwich the flanges on the tub between both clamps and the lock bracket. (See Figure 1)
3. Slide the tabs on the Main lid assembly into both of the brackets mounted in the tub and fasten it using (4) 10-32 x 1/2 screws #8.4 and (4) #10 washers #8.5. The location of the bracket in the tub can vary slightly. If the nuts in the Main lid assembly do not line up with the holes in the tub brackets the holes in the tub brackets may have to be elongated or drilled out to a larger size. (See Figure 2)
4. Test the lock. Some pressure may have to be applied to the lid to enable the lock cam to rotate into the locked position.

FIGURE 1

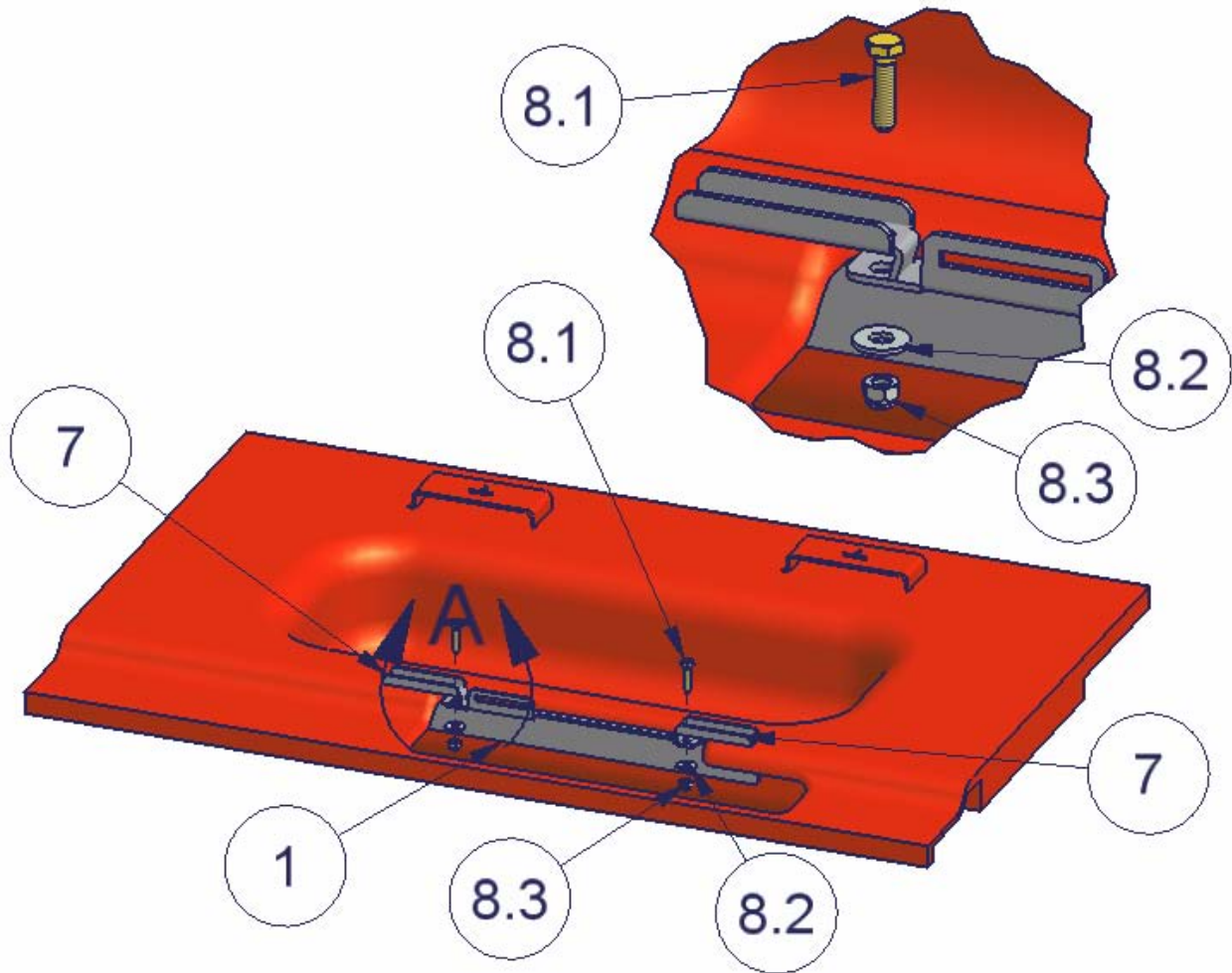
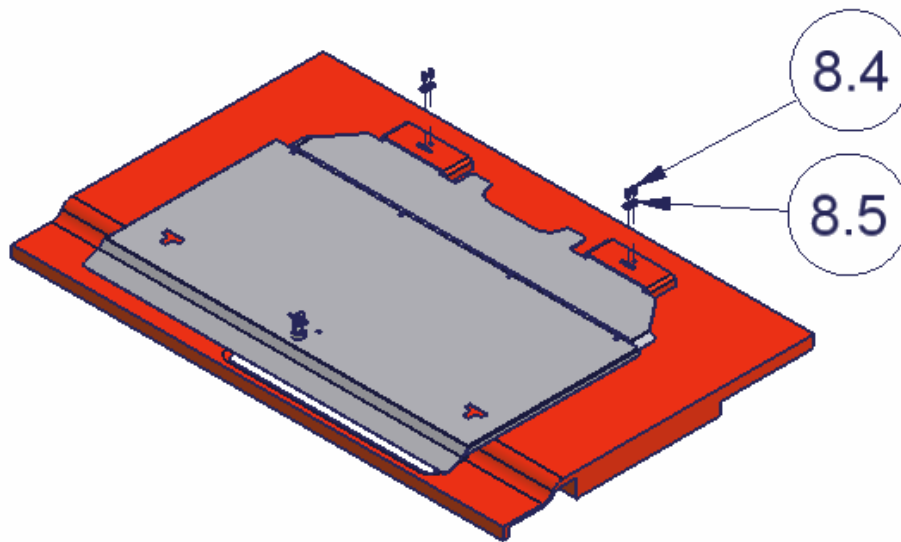

FIGURE 2



Call (970) 564-1762 for Technical Support