



# Installation Instructions

## Kit, Base Rail Bracket Part # 31397

### GM 2500/3500 Kit

**Dealer / Installer:** Provide a copy of these Instructions to the end user of this product. These Instructions provide important operating and safety information for proper usage of this product. Demonstrate the proper use of the product with the end user. Have the end user demonstrate that they understand the proper use of the product.

**End User:** Read and follow all instructions included in this manual. Ask your Dealer / Installer for assistance if you do not understand the proper use of the product. Never remove any decals from the product.

**NOTE:** This bracket kit is to be used with the 31323 4 Bolt Bed Rail Kit or 30686 10 Bolt Bed Rail Kit.

Complete Parts List		
Item No.	Description	Quantity
1	Bracket Left Frame Weldment	1
2	Bracket Right Frame Weldment	1
3	Plate, Spacer	4
4	Spacer Center Alignment	2
5	Spacer Offset Alignment	2
6	Spacer, Plate 1"	4
7	Bolt, Wheel 1/2-13 x 1-1/2"	2
8	Lock Nut Serrated 1/2-13	2
9	Bolt, Hex 5/8-11 x 3.25"	4
10	Washer, Lock, 5/8	4
11	Washer, Flat, 5/8	4
12	Clip Nut, 5/8-11	4
13	Bolt, Hex 3/4-10 x 2"	2
14	Washer, Lock, 3/4	2
15	Washer, Flat 3/4	2
16	Nut, Hex 3/4-10	2
17	Pull Wire 1/2"	1
18	Plate, Spacer 3/16"	2
19	**Spacer, Tube x 7/8"	2
20	**Screw, 6mm x 55mm	2
21	**Washer, Flat 6mm	2

**WARNING!** Never exceed the towing capacity of the tow vehicle.

**Center Bolt Kit 32059 must be used when towing with a 26K hitch, Goose Neck, or Maneuvering System (not included).**

Base Rails Not Included

Tools Required
3/4" Socket & Wrench
15/16" Socket & Wrench
5/8" Drill Bit
17/32" Drill Bit
Torque Wrench
Safety Glasses

\*\*Not used on vehicles that do not come equipped with the integrated brake control.

**CAUTION:** Do not install mounting rails over plastic bed liners. Plastic bed liners must be cut out of the way. Rails may be installed on spray in liners.

**NOTE:** Consult spray liner installer for recommended curing time.

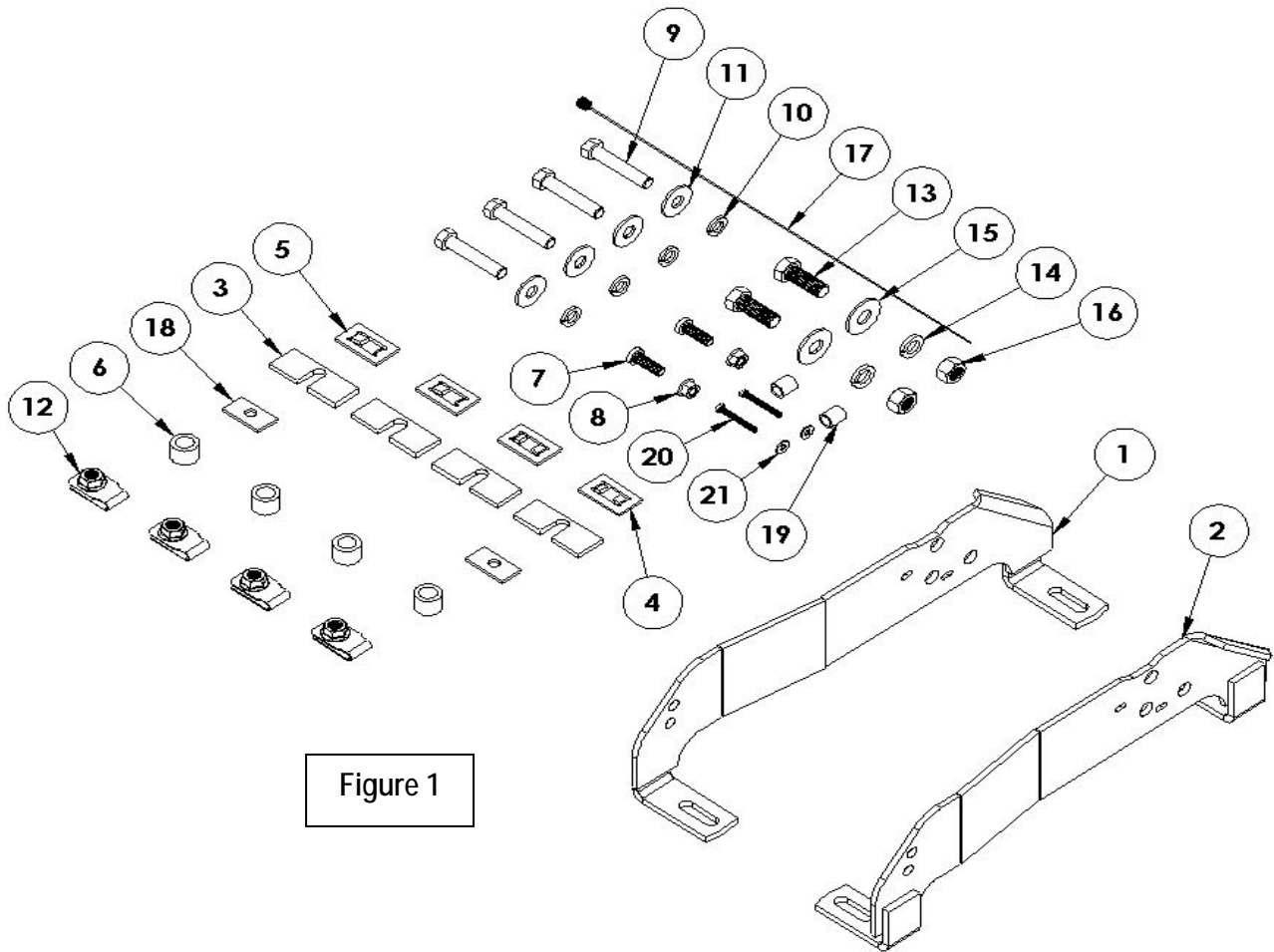
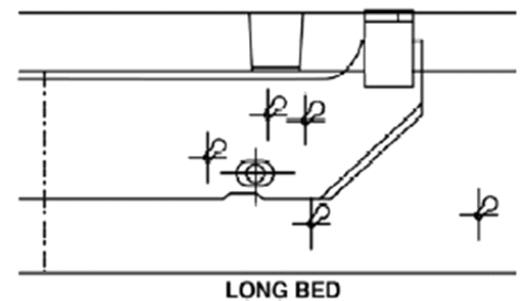
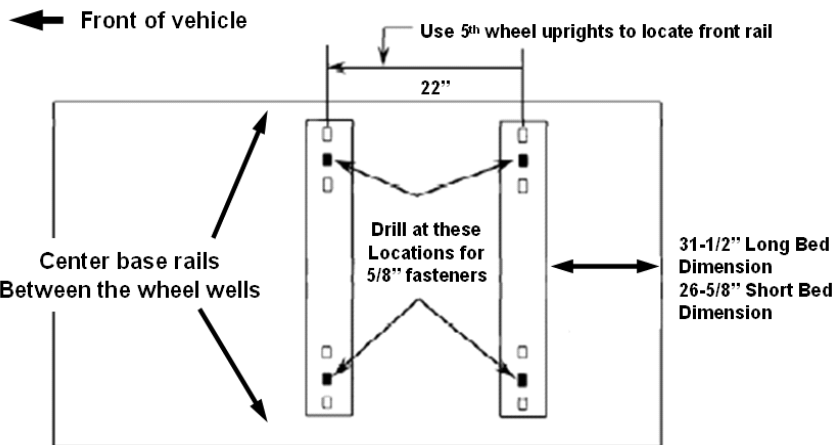
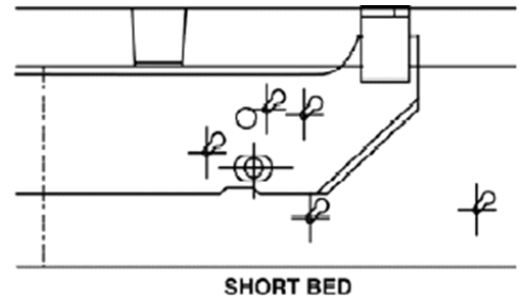
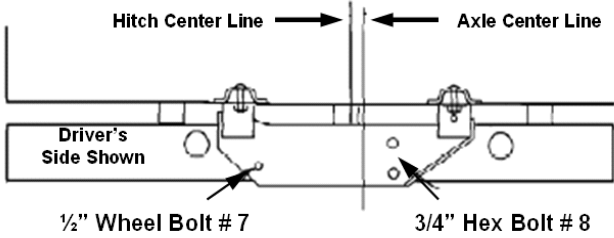

Figure 1

1-3/8" in front of axle on short bed applications  
 1-5/8" in front of axle on long bed applications



Note: Check cab clearance requirements before installing the hitch. The distance from the Cab to the hitch center line is approximately 56" for 8' long beds & 43" for 6.5' short beds.

Figure 2

1. Place the two bed rails across the truck bed between the wheel wells. Position the 5<sup>th</sup> wheel uprights between the bed rails so that the tabs in the base of each upright will fit into the slots in the ends of the bed rails. Secure the uprights in place with the rail hitch pins and hair pins supplied with the 5<sup>th</sup> wheel installation kit. Securely attach 5<sup>th</sup> wheel cross member to uprights.
2. Position the bed rail assembly in truck bed as shown in Figure 2. When hitch is correctly positioned in the bed and the bed rails are parallel, mark four attachment points on the truck bed using the 5/8" square holes indicated on the layout in Figure 2. Check below the bed before drilling holes to see that all wiring, brake lines or other obstructions are moved out of the way and will not be contacted by the drill. Move the hitch assembly out of the way and drill four 5/8" diameter attachment holes down through the bed at the previously marked points.
3. Reposition the bed rails in the bed so that the square 5/8" hole in the end of each rail is lined up over the drilled holes. Place a 3/4" thick spacer block (#6) under ends of each bed rail, in line with the drilled holes as shown on Figure 3.

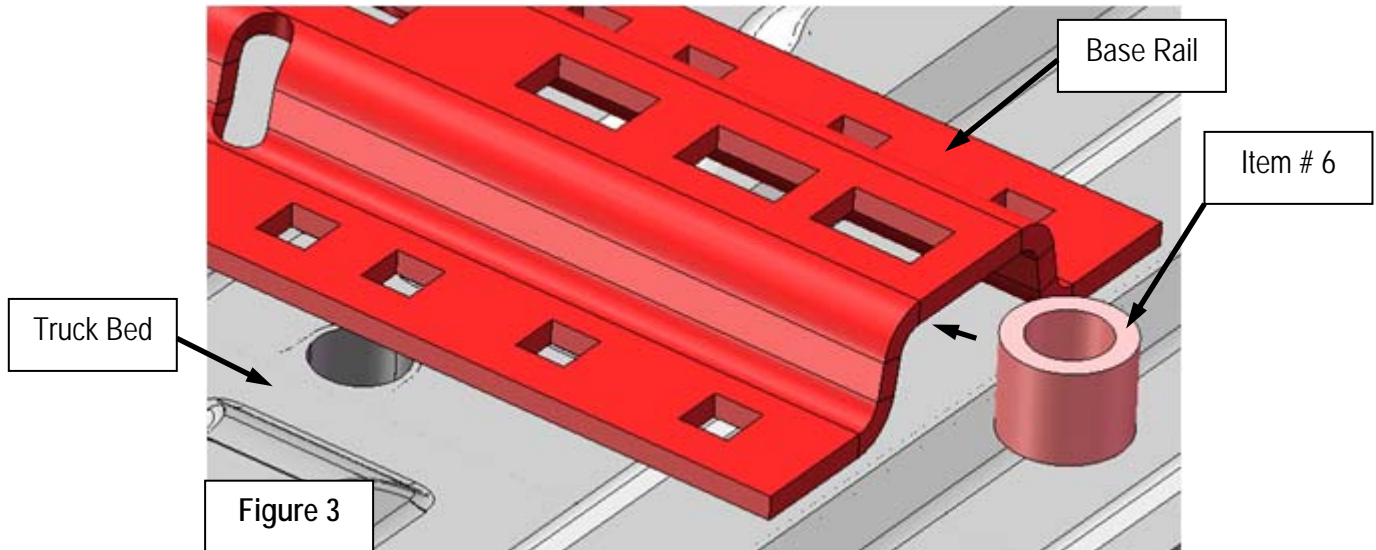

4. If the bed corrugation above the frame is UP, leaving a space above the frame bracket, place a spacer plate (#3) in the bed, under the base rail as shown on Figure 4.

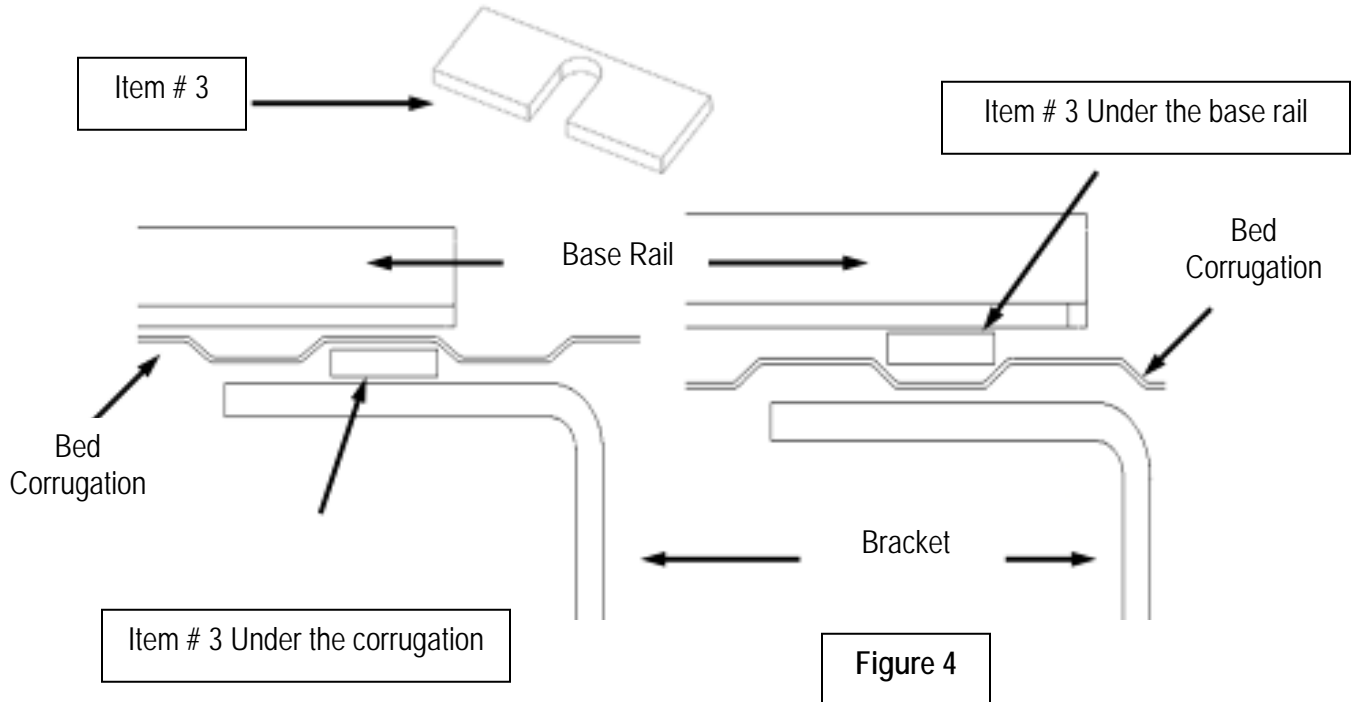

- Remove the two existing screws holding the forward IBC Unit onto the frame at the large 3/4" diameter bolt hole. Complete the installation then re-install the forward IBC Unit using longer 6mm bolts, flat washers, and tube spacers. See Figure 5.

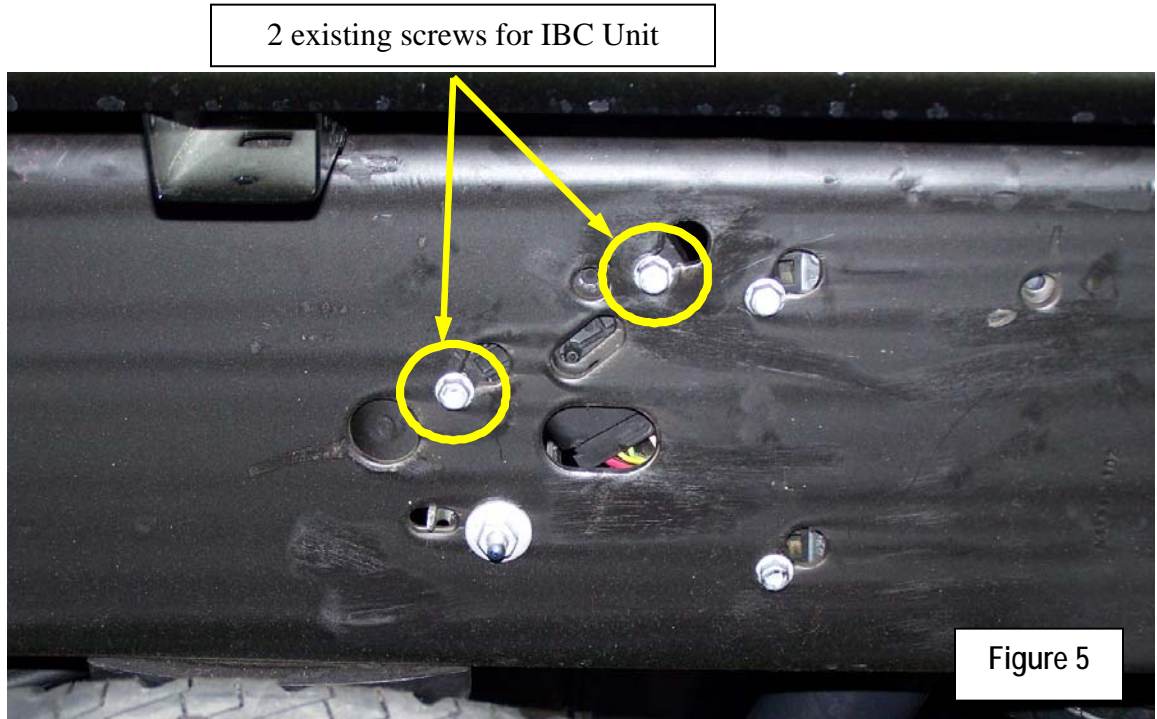

- Position the left and right frame brackets (#1) and (#2) up against the outer surface of the truck frame with the mounting tabs positioned over the frame and under the bed in line with previously drilled holes in bed. See Figure 6.

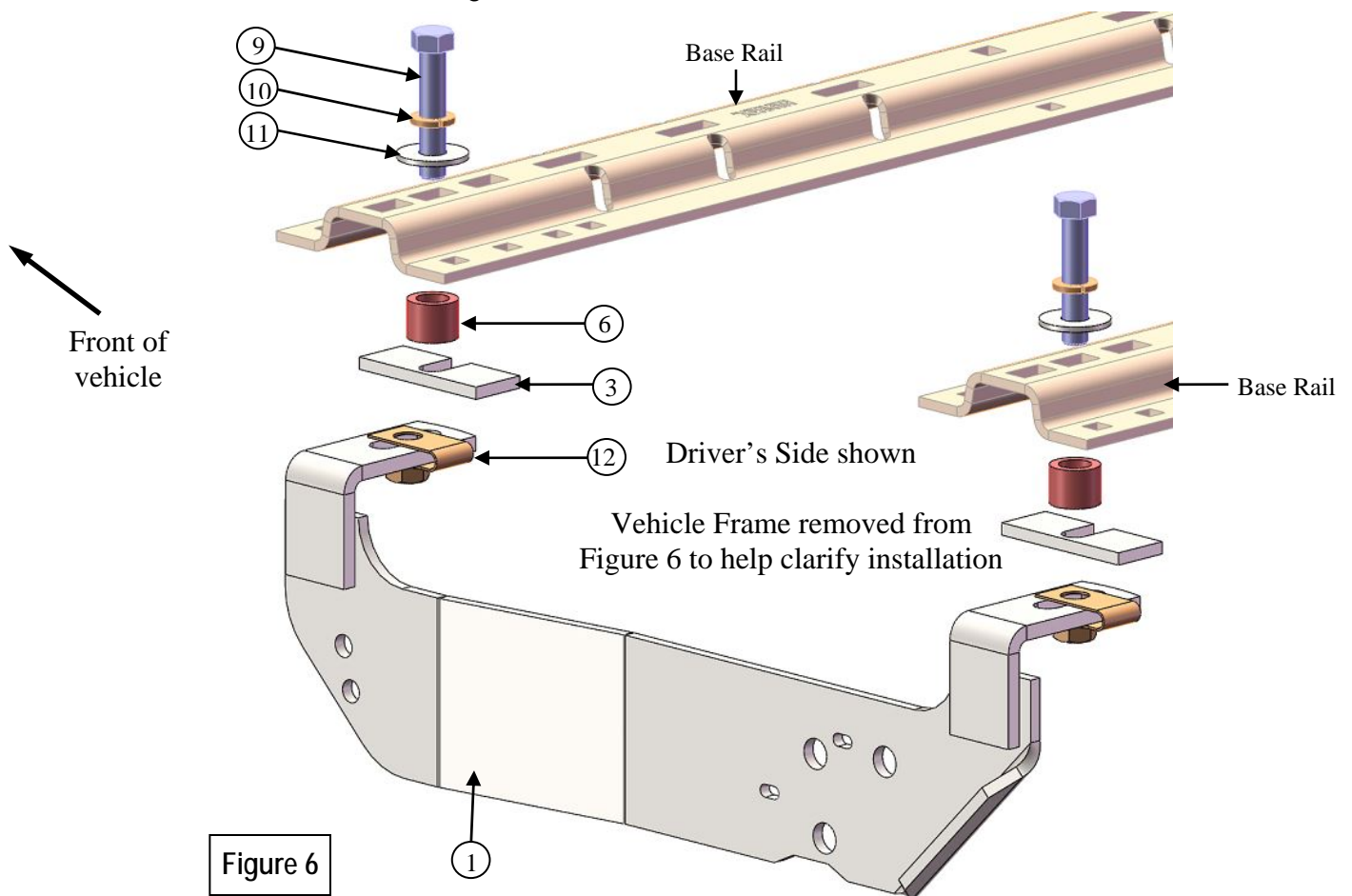

7. Move the frame brackets so that they rest tightly against the flat side of the truck frame and underneath surface of truck bed. Drop the 5/8" hex bolts down through 5/8 lock washer (#10), 5/8 flat washer (#11) and the bed rails and angle bracket. Thread bolts into clip Nuts (#12) placed over frame bracket tabs. See figure 6 & 6A .Securely bolt frame brackets in place.

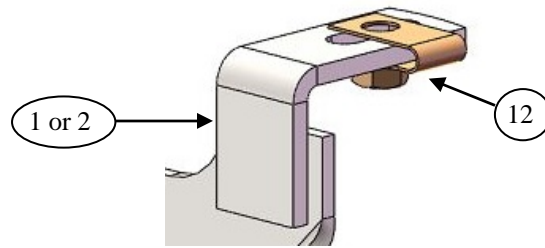

Figure 6 A

Be sure they are tight against the side of truck frame. See Figure 6. Tighten each 5/8" bed rail attachment bolt (#9) to 150 ft-lbs. torque. Failure to tighten bolts as described may result in fastener loss or failure. DO NOT apply torque to the nut portion of the clip nuts (#12). You will DAMAGE it.

8. Before drilling any holes, check inside the frame to be sure that there are no wires, brake lines or other obstructions in the frame which may be contacted by the drill. Also, check the forward frame bracket attachment hole to see if there is a hole in the truck frame that is aligned with hole in the frame bracket. Each of the frame brackets must be attached to the side of the frame of the truck with a special 1/2" wheel bolt at the forward hole and a 3/4" bolt at the rear hole.

- 8a. If there is no hole in the truck frame at the front attachment point, drill a 17/32" hole through the side of the truck frame using the hole in each frame bracket as a guide.

**CAUTION:** Holes MUST be drilled 17/32" diameter, so that the special wheel bolts will seat properly. If holes are too small, the bolt may break. If holes are too big, the bolt will not grip properly.

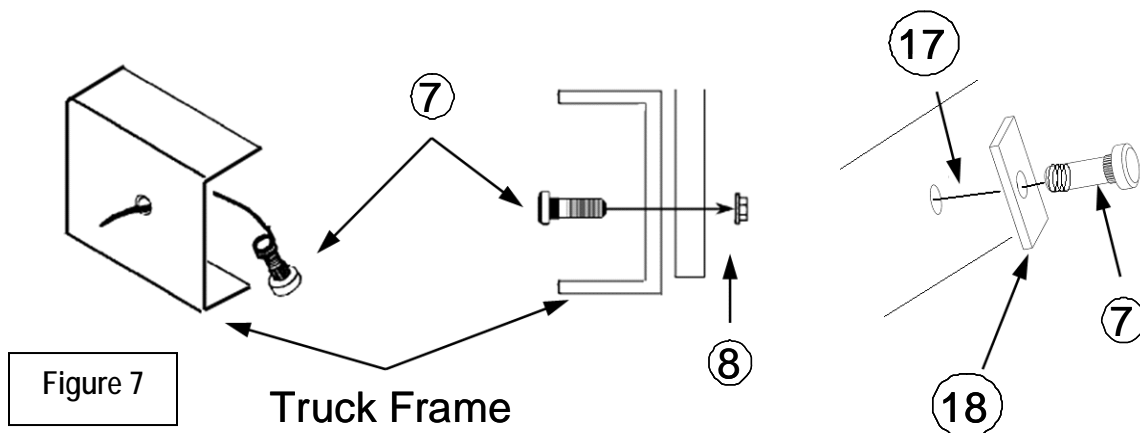

Figure 7

9. Place the wheel bolt into the frame first and then out through the frame brackets. See Figure 7. On applications with existing slots in frame, insert a 3/16" spacer on the pull wire before the bolt. Thread the pull wire coil over the end of the wheel bolt and pull through frame and frame bracket. See Figure 7. Secure each bracket to the truck frame. The knurled portion of the bolts will lock into the frame holes as the nuts are tightened. Use of an air wrench will make installation much better.

10. At the rear of each frame bracket there are two large attachment holes. Choose the one hole which lines up with the existing hole in the truck frame. Bolt frame bracket to truck frame with 3/4" fasteners as shown in Figure 8. Be sure to use one of the alignment spacers (#4 or #5) that will best line up with the bolt and large slot in the truck frame. Alignment spacer must rest fully into the large frame slot. See Figure 8.

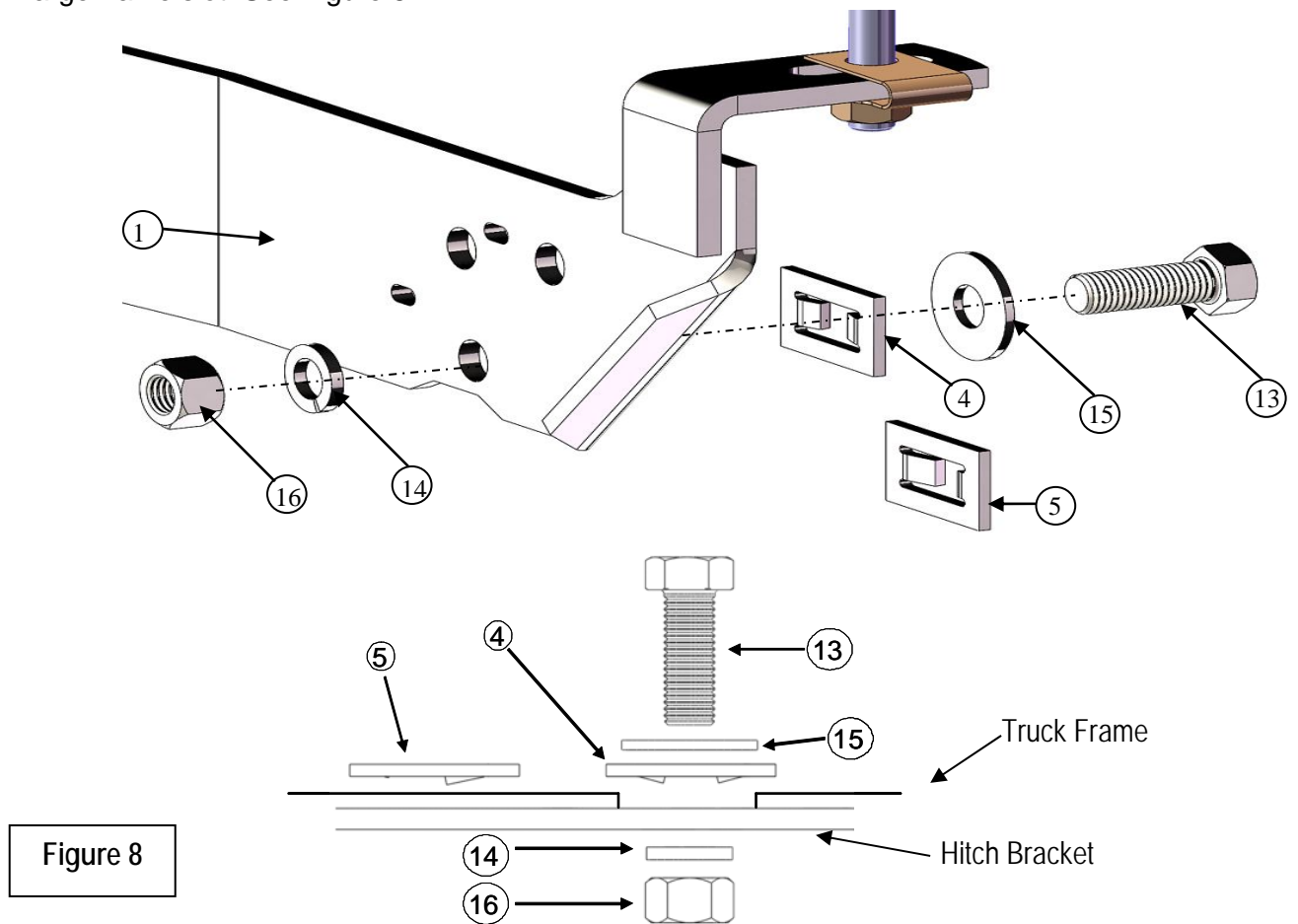

Figure 8

11. Tighten all 1/2" attachment bolts to 75 ft.-lbs. torque and the 3/4" bolts to 260 ft.-lbs. torque. Failure to tighten bolts as described may result in fastener loss or failure.
12. Check each rail hitch pin for freedom of movement in the bed rail connection before tightening the 5/8" carriage bolts. Adjust uprights, if necessary, by placing shim 30703 between the upright and the cross member to obtain free pin movement. See Figure 9.

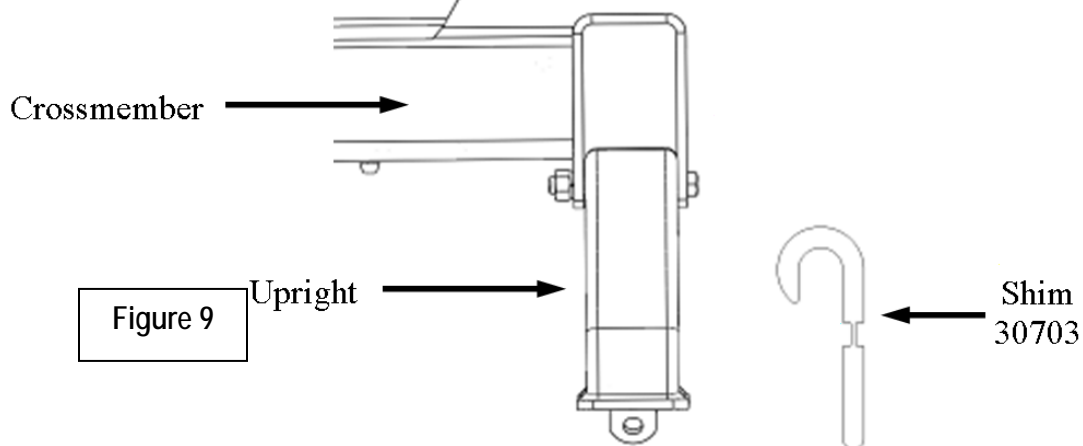

Figure 9

13. Tighten each 5/8" bed rail attachment bolt (#9) to 150 ft.-lbs. torque.

# Warranty Terms:

## 5 Year Limited Warranty:

This warranty applies solely to Husky 5<sup>th</sup> Wheel Installation Kit manufactured by LKQ Specialty Products Group for Husky Towing Products.

Husky Towing Products and LKQ Specialty Products Group make no guarantees or warranties for products not manufactured by LKQ Specialty Products Group. Such products are covered solely under any applicable warranty of the manufacturer. It is always recommended that the operating instructions and guarantee instructions provided by the manufacturer are followed.

LKQ Specialty Products Group warrants its products to be free from manufacturing and material defects to the original purchaser for the length of warranty stated above from the date of retail purchase. If any products are found to have a manufacturing or material defect, the product will be replaced or repaired at the option of Husky Towing Products and LKQ Specialty Products Group with proof of purchase by the original purchaser. The original purchaser shall pay all transportation and shipping costs associated with the return of the defective product and the defective product shall become the property of LKQ Specialty Products Group.

The Warranty applies to LKQ Specialty Products Group products used for individual and recreational purposes. Commercial usage of the LKQ Specialty Products Group products limits the warranty to 90-days from date of purchase.

The Warranty applies only to LKQ Specialty Products Group products which are found to be defective in manufacturing or material. This warranty does not apply to normal wear and tear of the finished product placed on LKQ Specialty Products Group products.

Husky Towing Products and LKQ Specialty Products Group are not responsible for any labor costs incurred for removal or replacement of the defective product. Husky Towing Products and LKQ Specialty Products Group are not responsible for repair or replacement of any product under the limited warranty where the product was improperly installed, misapplied, altered, abused, neglected, overloaded, misused or damaged as a result of an accident, including any use of the product not in accordance with all product operating and safety instructions.

Without limiting the generality of the foregoing, Husky Towing Products and LKQ Specialty Products Group shall under no circumstances be liable for any incidental or consequential loss or damage whatsoever arising out of, or in any way relating to any such breach of warranty or claimed defect in, or non-performance of the products. Some states do not allow the exclusion or limitation of incidental or consequential damages, so the above exclusion or limitation may not apply to you.

This limited warranty gives you specific legal rights, and you may also have other rights that vary from state to state.