

INSTALLATION INSTRUCTIONS

37031

80 – 96 Ford F-Series P.U. Reg. Cab, Bronco

Parts List :

QTY	(1) Hardware kit including :		
(1) Sidebar set (Driver & Passenger)	(6) 1/2 x 1 1/2" Hex head bolt	(2) 7/16-20h x 1" Hex head bolt	
(2) Front mounting bracket (Driver & Passenger)	(6) 1/2" Flat washer	(2) 7/16-14h X 1" Hex head bolt	
(2) Rear mounting bracket	(6) 1/2" Lock washer	(2) 7/16" Flat washer	
(2) Rear frame mounting bracket	(2) 1/2" Hex nut	(4) 7/16" Lock washer	
(2) Auxiliary mounting bracket	(2) 3/8 x 1" hex head bolt	(2) 7/16-20h x 1 3/4" Coupling nut	
(2) Spacer tubes	(2) 3/8" Flat washer	(2) 7/16-14h x 1 3/4" Coupling nut	
	(2) 3/8" Lock washer	(2) 3/8 x 1" Square head bolt	

Tools Required :

9/16" Socket	5/8" Socket	3/4" Wrench
3/4" Socket	5/8" Wrench	Ratchet

Instructions :

Approximated installation time: 30 min.

1. Read and understand instructions completely before beginning installation.
2. Sidebar set consist of a driver and passenger side. Be sure to determinate the correct side before installation.
3. Attach the following hardware to the vehicle:
 - Bolt the 7/16 - 14h x 1 3/4" hex coupling nut onto the front body mount and torque it to 40 ft./lbs.
 - Bolt the 7/16 - 20h x 1 3/4" hex coupling nut onto the seat belt bolt located near the rear of the door under the vehicle rocker panel and torque it to 40 ft./lbs.
4. Bolt the 3/8 x 1" square head bolt into the frame mounting bracket with a couple of turns. Attach the rear frame mounting bracket to the rear mounting bracket using 1/2 x 1 1/2" hex head bolts, 1/2" lock washers, 1/2" flat washers, and 1/2" hex nuts. The frame mounting bracket should be rotated forward about 10 degrees to match the angle of the vehicle frame. Hand tighten the 1/2" fasteners until snug.
5. Place the sidebar up to the vehicle. Hook the rear frame mounting bracket on the lower flange of the vehicle frame (Inclined area of vehicle frame) so that the front mounting bracket is directly below the coupling nut on the front body mount. Tighten the 3/8 x 1" square head bolt in the frame mounting bracket to hold the sidebar into place.
6. At the front of the sidebar, locate the spacer tube over the front body mount coupling nut and then insert the 7/16 - 14h x 1" hex head bolt with 7/16" lock washer and 7/16" flat washer up through the hole in the front mounting bracket and thread it into the 7/16 - 14h x 1 3/4" hex coupling nut. Torque the 7/16 - 14h x 1 3/4" hex head bolt to 40 ft./lbs.
7. Secure the auxiliary mounting bracket on the sidebar to the 7/16 - 20h x 1 3/4" hex coupling nut using a 7/16 - 20h x 1" hex head bolt, 7/16" lock washer, and 7/16" flat washer so that the hole in the bracket aligns with the hole in the center sidebar auxiliary mounting bracket. Make sure that the sidebars are aligned with the vehicle and then fasten the auxiliary mounting bracket to the sidebar using 3/8 x 1" hex head bolts, 3/8" lock washers, and 3/8" flat washers. Torque to 20 ft./lbs.
8. Make any final adjustments to the alignment of the sidebar and tighten all bolts. Repeat for the opposite side.
9. You may need to re-tighten the bolts periodically.

INSTALLATION INSTRUCTIONS

37031

80 – 96 Ford F-Series P.U. Reg. Cab, Bronco

Assembly Diagram :

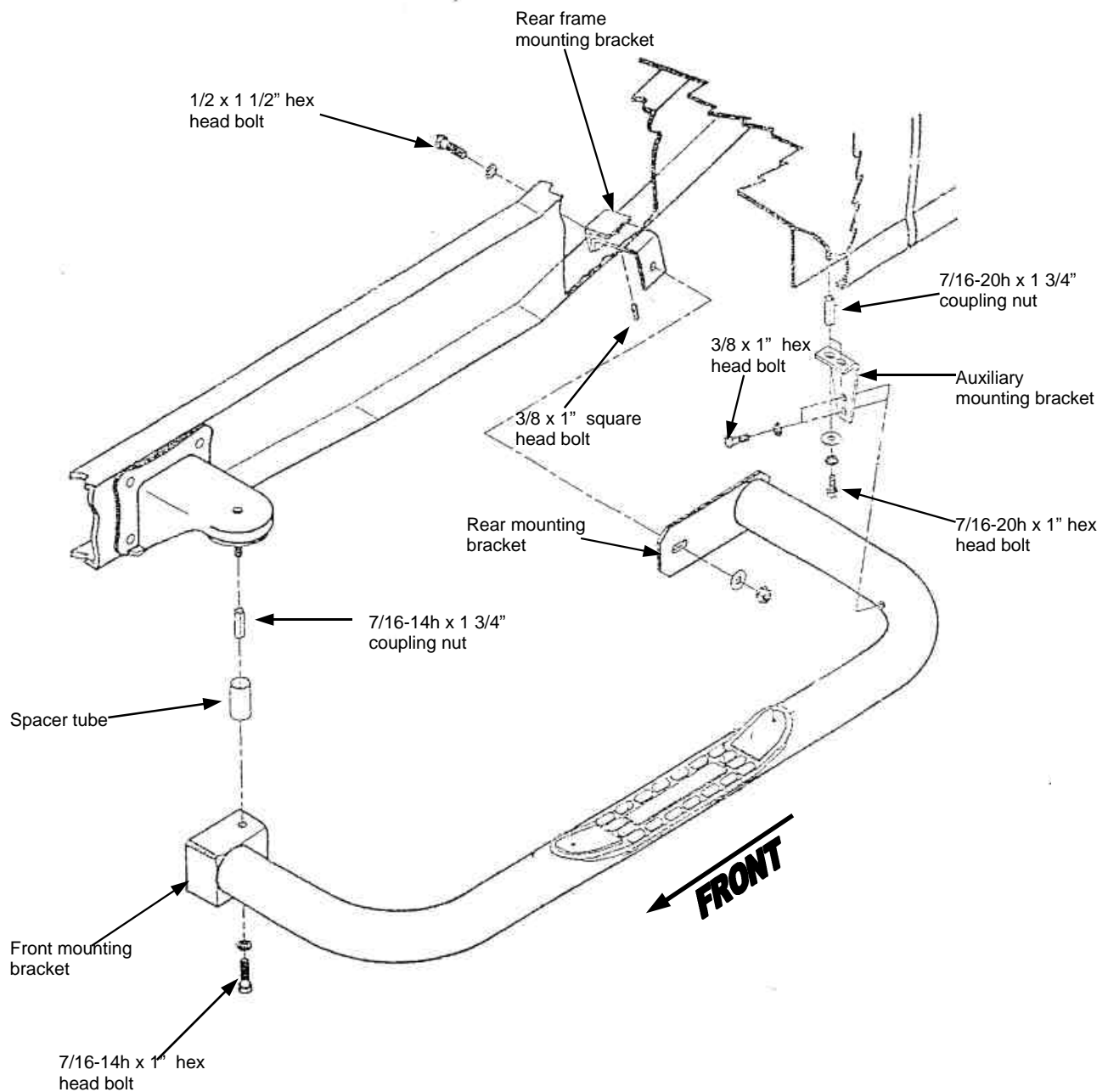

Cleaning and care instructions :

Protect the finish with a non-abrasive automotive wax, (e.g. Pure Carnauba) on a regular basis. The use of any soap, polish, or wax that contains an abrasive is detrimental to the finish, as the compounds scratch the finish and cause corrosion.