

INSTALLATION INSTRUCTIONS

BRK

TOYOTA RAV-4  
LIMITED 2007-2012

391865

PARTS LIST

Item	Qty.	Code	Description	Max. Torque
1	1	3911860AA	FRONT BRACKETS SET	
2	1	3911860BA	REAR PASSENGER SIDE BRACKET	
3	1	3911860CA	REAR DRIVER SIDE BRACKET	
4	2	-	1/2 " PLATE BOLT	
5	4	-	3/8 " PLATE BOLT	
	1	KTE-3911865	HARDWARE KIT	
6	4	-	FLAT WASHER 1/2	
7	4	-	LOCK WASHER 1/2 "	
8	2	-	FLAT WASHER 3/8 "	
9	2	-	LOCK WASHER 3/8"	
10	4	-	1/2 " HEX NUT	
11	2	-	3/8" HEX NUT	
12	2	-	1/4 X 1 " HEX BOLT	5.8 FT/LB
13	4	-	1/4 " FLAT WASHER	
14	2	-	1/4 " ALUMINIUM RIVET NUT	
15	2	-	M6 X 20 mm HEX BOLT	

TOOL REQUIRED:

- A. Ratchet: 3/8 "
- B. Socket: 9/16", 3/8", 3/4"
- C. Wrench: 9/16"

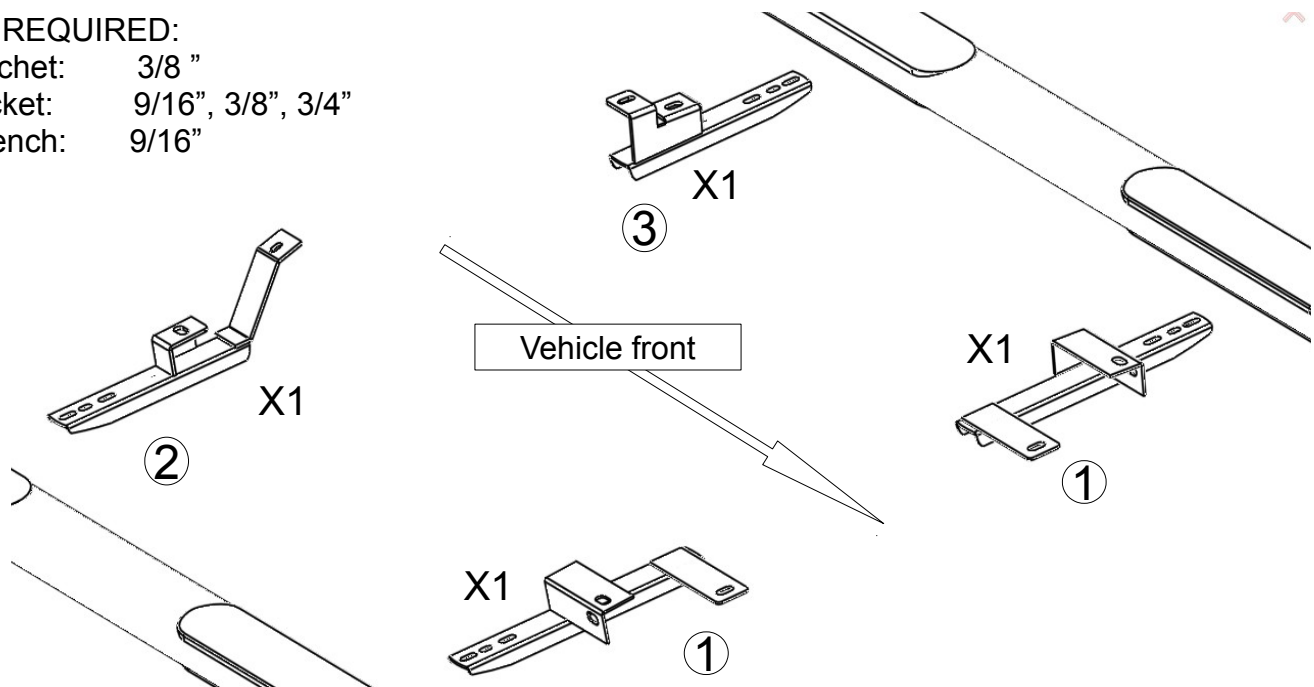

1. Before beginning the installation read all instructions Carefully and verify that all the hardware is accounted for. If there are any listed part missing please notify your distributor immediately.
2. To maintain and care this product keep it clean and do not use abrasive cleaners or polish waxes. We recommend to use only non-abrasive automotive wax such as pure carnauba to avoid scratches and rust.
3. The approximated installation time is 40 min.
4. Install the front bracket on the front side of the vehicle (img. 4) and secure it with a 3/8" plate bolt, flat washer, lock washer and hex nut. A 1/2" plate bolt, flat washer, lock washer and hex nut. And a M6X 20mm bolt. img.3

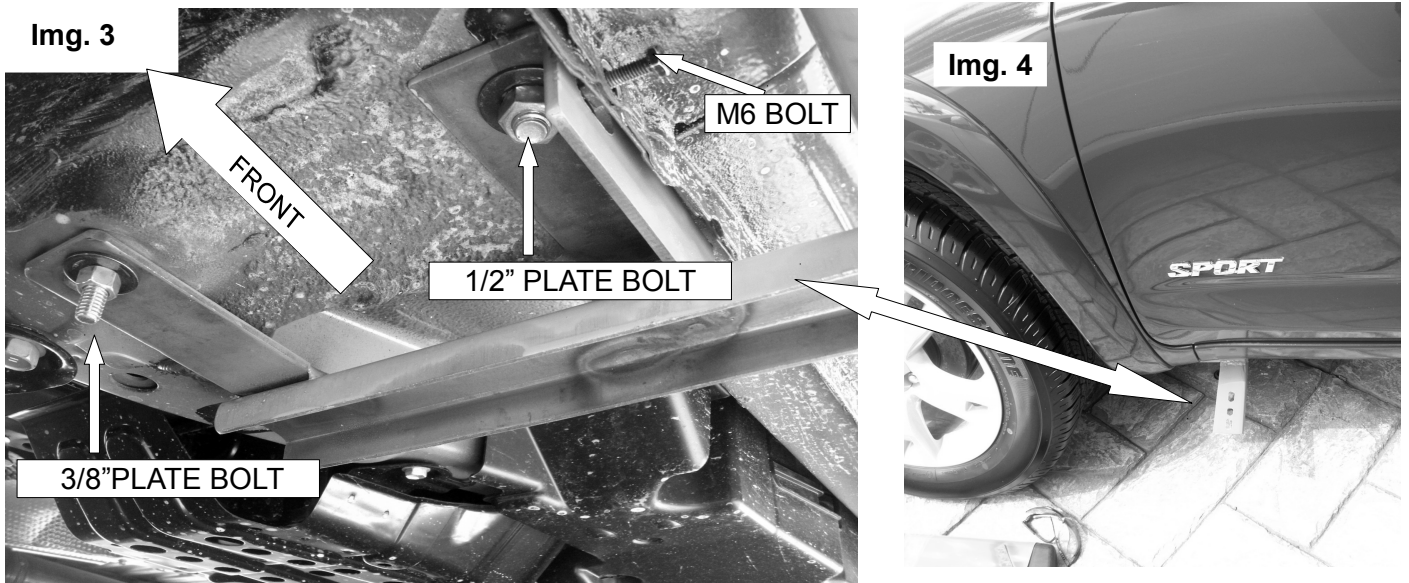

5. Install the rear driver side bracket, removing the gas tank support bolt img.5. Place the bracket and secure it with a 1/2 " bolt plate, flat and lock washers and the factory bolt previously removed. img. 5

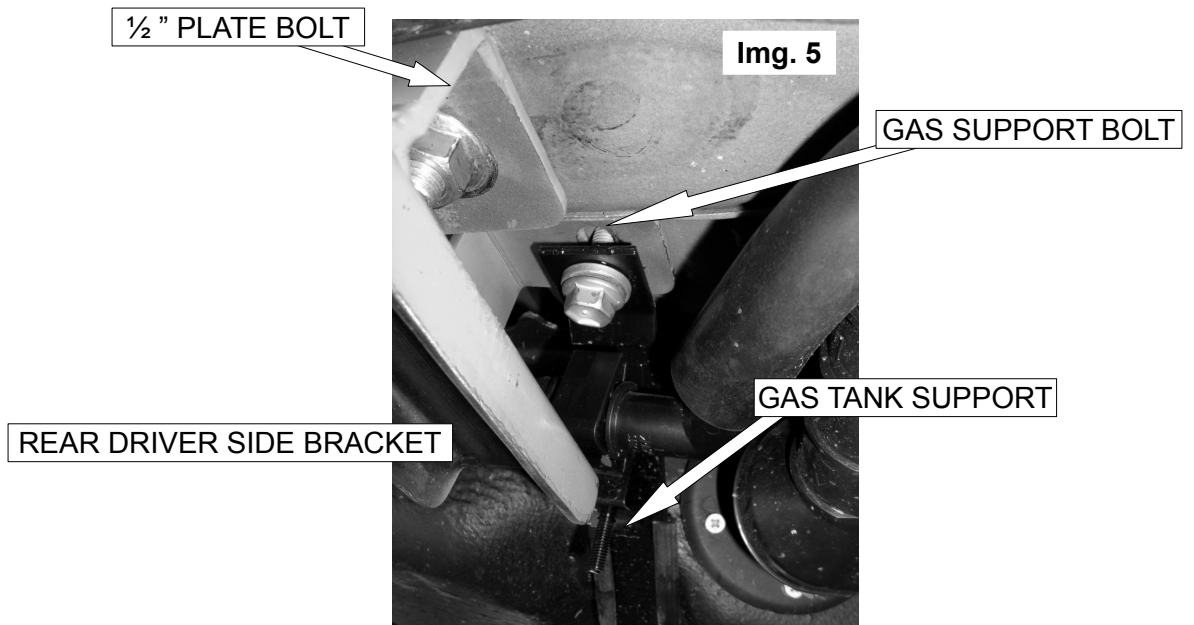

6. Assemble a ¼ " bolt, ¼ " flat washer, the rear passenger bracket, another ¼ " flat washer, and the rivet nut (img. 6) . Place the bracket in position img. 7 .Tight the bolt until the insert nut get fixed to the chasis. Remove the bolt and the washers to see the insert nut is fixed on the vehicle.

7. Secure the bracket using a ¼ " hex bolt, flat and lock washers and 3/8" plate bolt, flat and lock washers. " img 8.

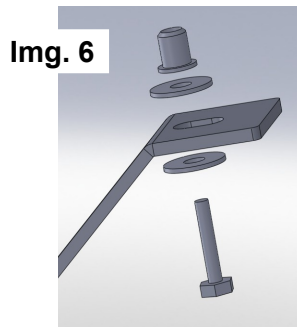

Img. 6

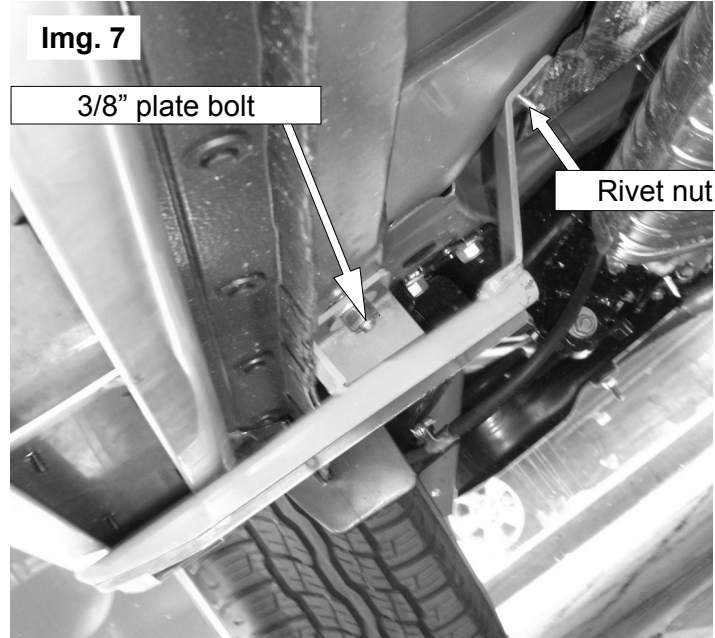

Img. 7

3/8" plate bolt

Rivet nut

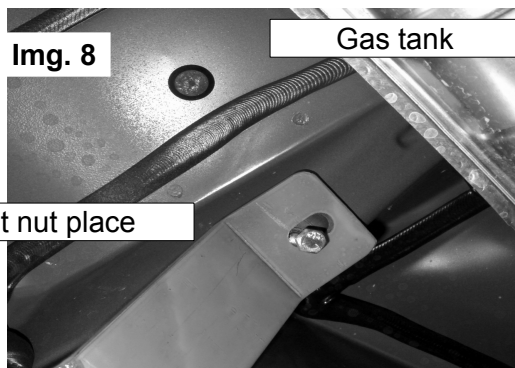

Img. 8

Gas tank

Rivet nut place

9. Place the side bar and adjust the wanted position between wheels. Tight all the hardware.



Wheels border