

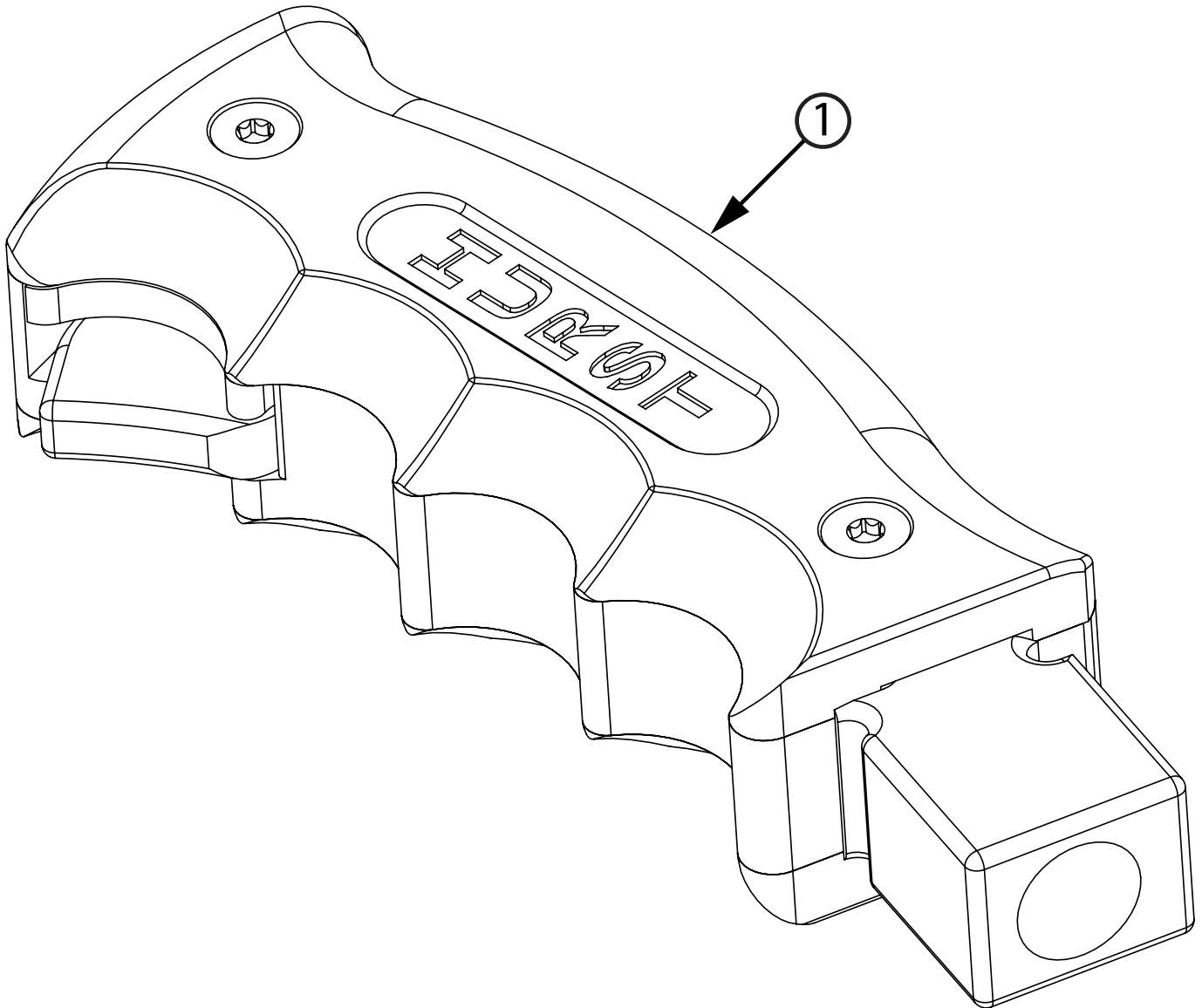

Installation Instructions for

Part No. 5380437

BILLET/PLUS® AUTO SHIFT HANDLE
FOR 2015-2020 DODGE CHALLENGER & CHARGER;
2018-2020 DODGE DURANGO



ITM #	PART #	DESCRIPTION	QTY.
1	5380437-39	Pistol Grip Assembled Handle	1
N/A	5380437BA-01	Hardware Pack includes:	1
2	97003157	M5-0.8 x 5MM Set Screw	1
3	5000116-99	Tie Wrap	1

OVERVIEW:



1. Please take a moment to read and understand these instructions before installing your Flowmaster performance system.

NOTE: Please inventory all parts before starting the installation process and call our tech line to report any missing parts. This will help avoid potentially stranding your vehicle until any missing replacement parts arrive.

WARNING:

For maximum safety, perform this installation on a clean, level surface with engine turned off.

CAUTION:

To avoid bodily injury or vehicle damage, chock wheels and do not attempt installation until you are confident your vehicle will not move.

REMOVE VEHICLE STOCK COMPONENTS:



NOTE: Challenger models do not require this step.

2. Remove forward rubber tray from center console.



3. Pry up front corners on console bezel then work your way around it to release remaining clips.



4. Lift up on bezel then unplug shift handle harness connector.



5. Remove factory set screw located at base of shift handle. Pull straight up on shift handle to remove handle and bezel assembly.



6. Release clips (x4) to remove shift boot and factory handle from bezel.



9. Separate shift boot from shift handle and wire harness.



7. Detach shift handle wire harness from mount on shift boot then pull it through boot loop.



10. The shift boot collar is attached to shift boot with glue. Separate collar from boot, being cautious not to tear boot.



8. Release clips (x2) that mount shift boot retaining collar to shift handle.



- NOTE:** Challenger models do not require this step.
11. Remove screws (x2) from front console storage tray.



NOTE: Challenger models do not require this step.

12. Pull straight back on upper part of storage tray to release clips. Remove tray from console.



13. The factory shifter features a computer chip for illuminated gear select indicator. If disconnected, the vehicle ECM will not see it and an error light will be generated. To remedy this, plug factory shift handle back into factory connector.

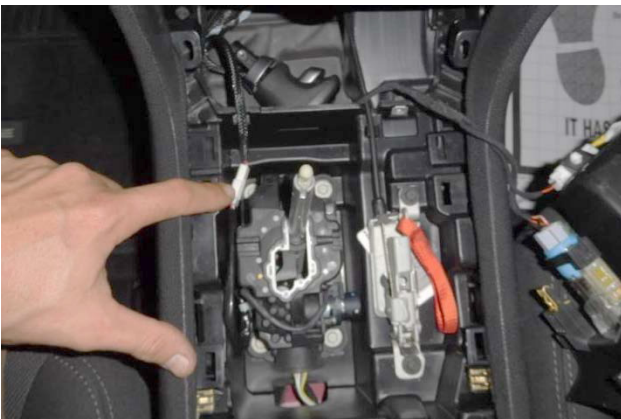

14. Route harness to driver side of shifter housing. Place stock handle into empty space in front of shifter housing under tray (removed step 11). Challenger models have an empty space just forward of shifter housing.



NOTE: Challenger models do not require this step.

15. Reinstall lower tray, ensuring wire harness is routed through opening shown.



16. Reinstall factory bezel.

Install Hurst Pistol Grip Handle kit:



17. With boot inverted, insert **pistol grip (1)** into boot, orienting it as shown.



18. Slide boot up pistol grip base as far as it will go. Then apply a small drop of thread locking fluid to set screw (2) threads and start it in pistol grip.



21. Clip shifter boot back into bezel. Shift through all positions to ensure proper installation.



19. Slide pistol grip about halfway down shift rod. Run set screw in until it bears lightly on shift rod. This assists in aligning set screw with dimple on shift rod. After it is aligned, tighten screw fully.



Congratulations, the installation of your Hurst Pistol Grip Handle is now complete!



20. Align zip tie (3) with notch at base of pistol grip. Tighten zip tie and trim excess.

