

2360 Boswell Road
Chula Vista, CA 91914
Phone 619.216.1444
Fax 619.216.1474
E-Mail tech@explorerprocomp.com



PRO COMP SUSPENSION

Suspension Systems that Work!

**Part # 72096
Traction Bar Kit
2004-2005 Ford F150
Super Crew Cab
2WD & 4WD**

This document contains very important information that includes warranty information and instructions for resolving problems you may encounter. Please keep it in the vehicle as a permanent record.

Part #	Description	Qty.	Illus.	Page
72096	TRACTION BAR MOUNTING KIT			
90-1900	2004 F150 REAR TRACTION BAR MOUNT DRIVERS	1	1	4
90-1904	2004 F150 REAR TRACTION BAR MOUNT PASS	1	-	-
90-3023	2004 F150 FRONT TRACTION BAR MOUNT DRIVERS	1	3a,b,c,d	6
90-3026	2004 F150 FRONT TRACTION BAR MOUNT PASS	1	-	-
90-6163	HARDWARE PACK: BUSHINGS	1	-	-
90-2192	SLEEVE 7/8" X 9/16" X 3.9375"	2	2	5
90-2193	SLEEVE 7/8" X 9/16" X 2.8125"	2	2	5
15-10953	BUSHING - TRAC BAR	8	2	5
90-6120	HARDWARE PACK: MOUNTS	1	-	-
70-0505501800	1/2" X 5 1/2" GR 8 HEX BOLT	2	2	5
70-0504501800	1/2" X 4 1/2" GR 8 HEX BOLT	2	2	5
73-05000032	1/2" USS GR 8 FLAT WASHER	8	2	5
72-050100816	1/2" GR 8 STOVER NUT	4	2	5
90-6391	HARDWARE PACK: MOUNTS	1	-	-
70-0431001800	7/16" X 1" GR 8 HEX BOLT	6	3a,b,d	6
73-04300032	7/16" USS GR 8 WASHER	6	3a,b,d	6
90-3151	SIDE NUT PLATE	6	3a,b,d	6
90-6394	HARDWARE PACK: SUPER CREW TRACTION BARS	1	-	-
73-06200032	5/8" USS GRADE 5 FLAT	8	1	4
Additional parts needed:				
72500	50" TRACTION BARS W/LOGO			
90-2435	LATERAL TRACK BAR DRIVER	1	2	5
90-2437	LATERAL TRACK BAR PASSENGER	1	-	-

Equipment Available from your Pro Comp Distributor!

Skid plates	52104 (4WD)
Traction Bars (Extra cab)	Mounting kit: 72095, Bars: 72500
MX6 Rear shock	MX6079(2WD), MX6009(4WD)
Coil over upgrade kit	52206MX 4WD, 52207MX 2WD
Add a leaf kit	13134
Rear End Shim Kit	52700

Also, Check out our outstanding selection of Pro Comp tires to compliment your new installation!

Introduction:

- ◆ This installation requires a professional mechanic!
- ◆ We recommend that you have access to a factory service manual to assist in the disassembly and reassembly of your vehicle. It contains a wealth of detailed information.
- ◆ Ensure that your work space is of adequate size and the work surface is level. Place the vehicle in neutral. Place your floor jack under the front cross member and raise vehicle. Place jack stands under the frame rails behind the front wheel wells and lower the frame onto the stands. Remove the jack and place the vehicle back in gear, set the emergency brake, and place blocks both in front and behind the rear wheels.
- ◆ Prior to installation, carefully inspect the vehicle's steering and driveline systems paying close attention to the tie rod ends, ball joints, wheel bearing preload, pitman and idler arm. Additionally, check steering-to-frame and suspension-to-frame attaching points for stress cracks. The overall vehicle must be in excellent working condition. Repair or replace all worn or damaged parts!
- ◆ Read the instructions carefully and study the illustrations before attempting installation! You may save yourself a lot of extra work.
- ◆ Check the parts and hardware against the parts list to assure that your kit is complete. Separating parts according to the areas where they will be used and placing the hardware with the brackets before you begin will save installation time.
- ◆ Check the special equipment list and ensure the availability of these tools.
- ◆ Secure and properly block vehicle prior to beginning installation.
- ◆ ALWAYS wear safety glasses when using power tools or working under the vehicle!
- ◆ Use caution when cutting is required under the vehicle. The factory undercoating is flammable. Take appropriate precautions. Have a fire extinguisher close at hand.
- ◆ Foot pound torque readings are listed on the Torque Specifications chart at the end of the instructions. These are to be used unless specifically directed otherwise. Apply thread lock retaining compound where specified.
- ◆ *Please note that while every effort is made to ensure that the installation of your Pro Comp lift kit is a positive experience, variations in construction and assembly in the vehicle manufacturing process will virtually ensure that some parts may seem difficult to install. Additionally, the current trend in manufacturing of vehicles results in a frame that is highly flexible and may shift slightly on disassembly prior to installation. The use of pry bars and tapered punches for alignment is considered normal and usually does not indicate a faulty product. However, if you are uncertain about some aspect of the installation process, please feel free to call our tech support department at the number listed on the cover page. We do not recommend that you modify the Pro Comp parts in any way as this will void any warranty expressed or implied by the Pro Comp Suspension company.*
- ◆ Check the parts and hardware against the parts list to assure that your kit is complete.
- ◆ Always use new cotter pins (these items are not supplied) when replacing them.
- ◆ MX6 shocks may hit the traction bar mount, if it does a ES series shock should be used.

INSTALLATION INSTRUCTIONS:

- 1) Place a floor jack under the rear axle and raise the vehicle. Place jack stands under the frame to support the vehicle. Set the emergency brake and the block front wheels, in front and behind the tires. Remove the rear wheels and shocks.
- 2) Work on one side of the vehicle at a time.
- 3) Support the rear axle, on the driver side unbolt the U-bolts and install the lateral traction bar rear mount (**90-1900 drivers side and 90-1904 passenger side**) under the lower axle bracket as shown in ILLUSTRATION 1. Be sure when tightening to keep the mount parallel with the leaf spring.

NOTE: For vehicles equipped with a cast lower axle bracket the (8) 5/8" washers will need to be installed in between the factory lower axle bracket and the traction bar rear mounts.

- 4) Reinstall the U-bolts and tighten. Repeat on the other side.
- 5) Torque the U-bolts to 85 ft. lbs.
- 6) Place the floor jack under the rear axle and raise the vehicle. Move the jack stands under the rear axle to support vehicle and lower it onto the jack stands.

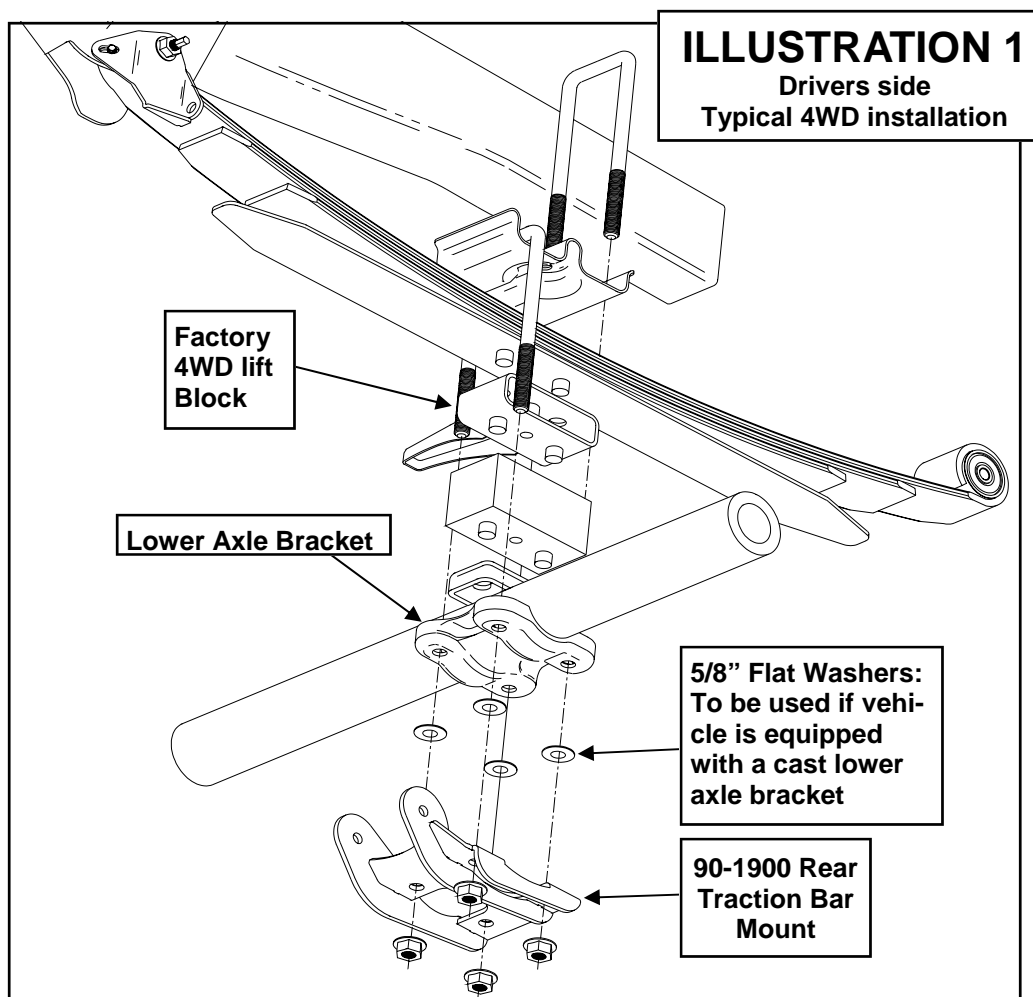

NOTE: If installing this kit while the vehicle is on a lift, be sure to lower it to the ground before installing the front mounts and the traction bars.

- 7) Install the bushings (**15-10593**) and sleeves (**90-2193 front and 90-2192 rear**) into the lateral traction bar tubes as shown in ILLUSTRATION 2. Use lubricant as necessary.
- 8) Install the lateral traction bars (**90-2435 drivers side and 90-2437 passenger side**) into the rear mounts using the supplied **1/2" X 5 1/2"** bolts and hardware. See ILLUSTRATION 2. Do not torque at this time.
- 9) Using the supplied **1/2" X 4 1/2"** bolt and hardware attach the front mounts (**90-3023 driver side and 90-3026 passenger side**) to the lateral traction bars. Do not torque at this time. See ILLUSTRATION 2.
- 10) Raise the traction bar to the frame. One at a time, slide **(2)** nut plates (**90-3151**) into the smaller hole behind the front mount in the frame. Line the nut plates up with the existing side and front lower holes in the frame and secure with the supplied **(2) 7/16" X 1"** bolts and washers. See ILLUSTRATION 3A,3B.
- 11) Unbolt and lower the traction bar from the front mount. Using the front mount as a template center punch and drill out the remaining lower rear hole using a **15/32"** drill bit. See ILLUSTRATION 3C.

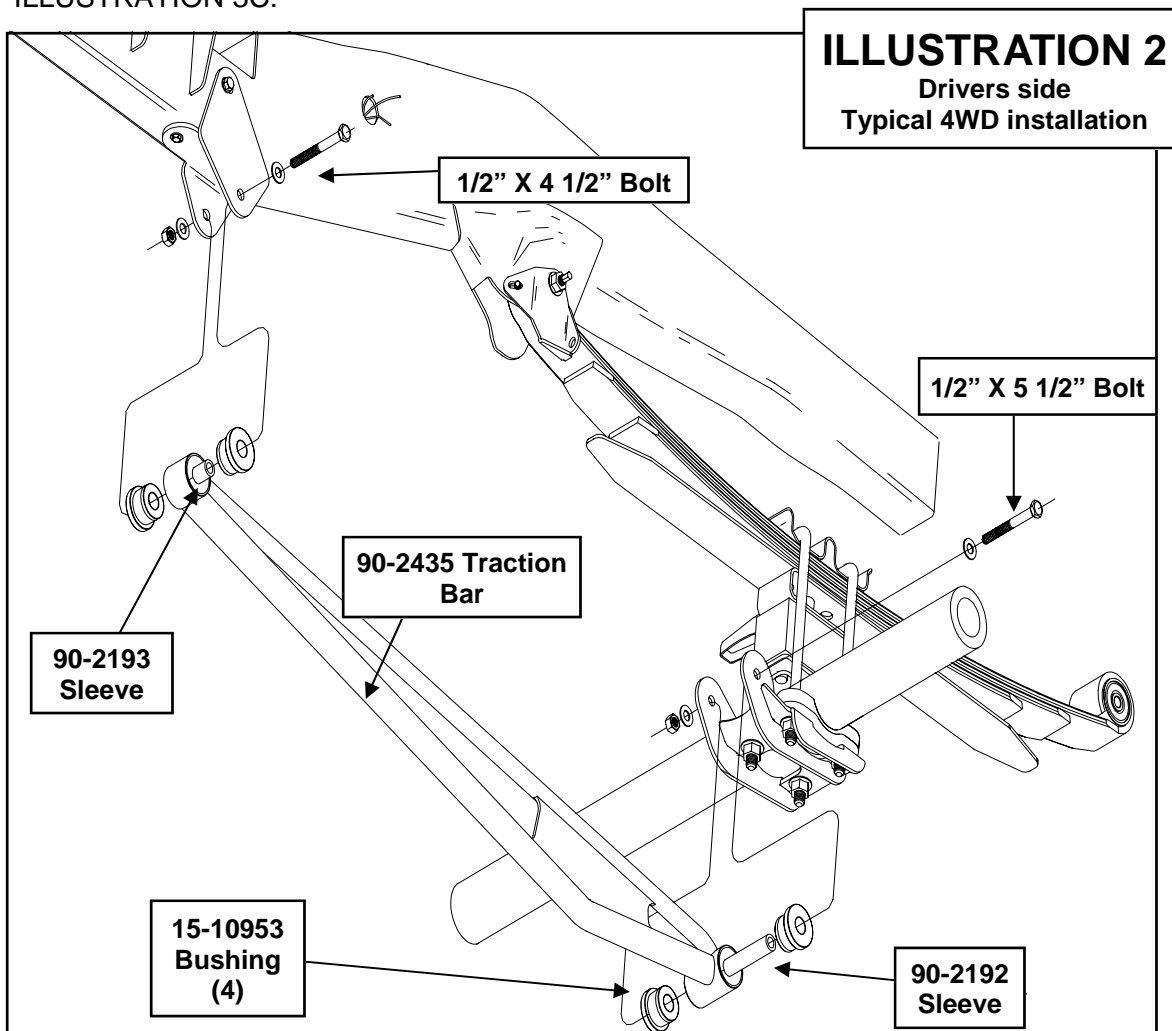

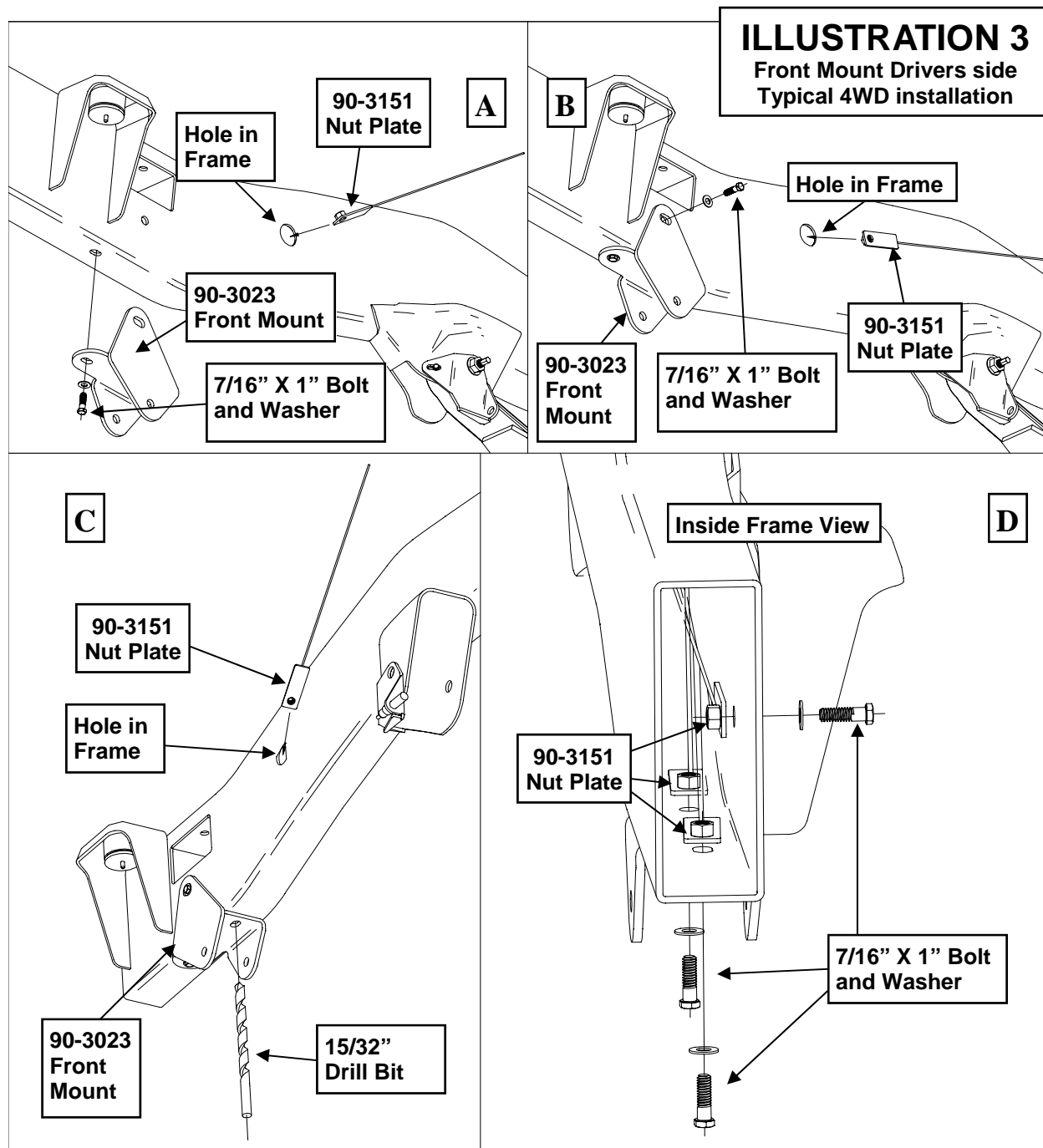

- 12) Slide the remaining nut plate (**90-3151**) into the hole in the frame and line it up with the newly drilled rear lower hole in the frame and secure with the supplied **7/16" X 1"** bolts and washers. See ILLUSTRATION 3D.
- 13) Swing the traction bar up and refasten to the front mount using the **1/2 X 4 1/2"** bolt and hardware. See ILLUSTRATION 2.
- 14) Clip off excess wire from the nut plates when finished. Be sure to leave enough wire for future access. Bundle wires with a zip tie to keep from rattling.
- 15) Repeat this installation on the remaining side of the vehicle.

- 16) Raise rear axle until it clears the jack stands and remove them. Lower the vehicle to the ground.
- 17) After installation is complete, retighten and torque all bolts as specified in the torque chart.

Use this only as a guide for hardware without a called out torque specification in the instruction manual.

Bolt Torque and ID							
Decimal System				Metric System			
All Torques in Ft. Lbs. Maximums							
Bolt Size	Grade 5	Grade 8	Bolt Size	Class 9.8	Class 10.9	Class 12.9	
5/16	15	20	M6	5	9	12	
3/8	30	45	M8	18	23	27	
7/16	45	60	M10	32	45	50	
1/2	65	90	M12	55	75	90	
9/16	95	130	M14	85	120	145	
5/8	135	175	M16	130	165	210	
3/4	185	280	M18	170	240	290	

1/2-13x1.75 HHCS **Grade 5 Grade 8**
(No. of Marks + 2)

D T L X

G = Grade (Bolt Strength)
D = Nominal Diameter (Inches)
T = Thread Count (Threads per Inch)
L = Length (Inches)
X = Description (Hex Head Cap Screw)

M12-1.25x50 HHCS

D T L X

P = Property Class (Bolt Strength)
D = Nominal Diameter (Millimeters)
T = Thread Pitch (Thread Width, mm)
L = Length (Millimeters)
X = Description (Hex Head Cap Screw)

Notice to Owner operator, Dealer and Installer:

Vehicles that have been enhanced for off-road performance often have unique handling characteristics due to the higher center of gravity and larger tires. This vehicle may handle, react and stop differently than many passenger cars or unmodified vehicles, both on and off-road. You must drive your vehicle safely! Extreme care should always be taken to prevent vehicle rollover or loss of control, which can result in serious injury or even death. Always avoid sudden sharp turns or abrupt maneuvers and allow more time and distance for braking! Pro Comp reminds you to fasten your seat belts at all times and reduce speed! We will gladly answer any questions concerning the design, function, maintenance and correct use of our products.

Please make sure your Dealer/Installer explains and delivers all warning notices, warranty forms and instruction sheets included with Pro Comp product.

Application listings in this catalog have been carefully fit checked for each model and year denoted. However, Pro Comp reserves the right to update as necessary, without notice, and will not be held responsible for misprints, changes or variations made by vehicle manufacturers. Please call when in question regarding new model year, vehicles not listed by specific body or chassis styles or vehicles not originally distributed in the USA.

Please note that certain mechanical aspects of any suspension lift product may accelerate ordinary wear of original equipment components. Further, installation of certain Pro Comp products may void the vehicle's factory warranty as it pertains to certain covered parts; it is the consumer's responsibility to check with their local dealer for warranty coverage before installation of the lift.

Warranty and Return policy:

Pro Comp warrants its full line of products to be free from defects in workmanship and materials. Pro Comp's obligation under this warranty is limited to repair or replacement, at Pro Comp's option, of the defective product. Any and all costs of removal, installation, freight or incidental or consequential damages are expressly excluded from this warranty. Pro Comp is not responsible for damages and / or warranty of other vehicle parts related or non-related to the installation of Pro Comp product. A consumer who makes the decision to modify his vehicle with aftermarket components of any kind will assume all risk and responsibility for potential damages incurred as a result of their chosen modifications. Warranty coverage does not include consumer opinions regarding ride comfort, fitment and design. Warranty claims can be made directly with Pro Comp or at any factory authorized Pro Comp dealer.

IMPORTANT! To validate the warranty on this purchase please be sure to mail in the warranty card.

Claims not covered under warranty-

- Parts subject to normal wear, this includes bushings, bump stops, ball joints, tie rod ends and heim joints
 - Discontinued products at Pro Comp's discretion
- Bent or dented product
- Finish after 90 days
- Leaf or coil springs used without proper bump stops
- Light bulbs
- Products with evident damage caused by abrasion or contact with other items
- Damage caused as a result of not following recommendations or requirements called out in the installation manuals
- Products used in applications other than listed in Pro Comp's catalog
- Components or accessories used in conjunction with other manufacturer's systems
- Tire & Wheel Warranty as per Pro Competition Tire Company policy
- Warranty claims without "Proof of Purchase"
- Pro Comp Pro Runner coil over shocks are considered a serviceable shock with a one-year warranty against leakage only. Rebuild service and replacement parts will be available and sold separately by Pro Comp. Contact Pro Comp for specific service charges.
- Pro Comp accepts no responsibility for any altered product, improper installation, lack of or improper maintenance, or improper use of our products.

E-Mail: tech@explorerprocomp.com
Website: www.explorerprocomp.com
Fax: (619) 216-1474
Ph: (619) 216-1444

PLACE
WARRANTY REGISTRATION
NUMBER
HERE: _____