



INSTRUCTIONS—INSTRUCCIONES—CONSIGNES

APPLICATION: 2011-UP FORD EXPLORER
APP PART # 32-3570, 32-3575
BULL BAR

AUTOMOTIVE PRODUCTS, INC.

ITEM	QUANTITY	DESCRIPTION	TOOLS NEEDED
1	2	BULL BAR	9/16 WRENCH
2,3	2	MOUNTING BRACKETS (2) DRIVERS SIDE, (3) PASSENGER SIDE	9/16 SOCKET
4	2	SPACER PLATES	RATCHET
5	2	3/8 BOLT PLATE/NUT PLATE	TORQUE WRENCH
6	2	3/8 HEX HEAD BOLTS	
7	4	3/8 FLAT WASHER	
8	4	3/8 LOCK WASHER	
9	4	3/8 HEX NUTS	
10	4	3/8 SERRATED FLANGE BOLTS	
11	4	3/8 SERRATED FLANGE NUT	

1. Remove contents from box, verify if all parts listed are present and free from damage. Carefully read and understand all instructions before attempting installation.
2. Starting at the front of the vehicle, take the drivers side mounting bracket and hold it up the mounting locations on the frame. Note where the bracket is coming in contact with the front plastic valance and trim valance to fit around the brackets. Repeat this step for the passenger side.
3. Take (1) 3/8 bolt plate/nut plate and place it in the most rearward hole of the frame FIG 1, take (1) spacer plate and place it between the frame and the front mounting location of the mounting bracket FIG 2. Attach the mounting bracket to the front mounting location using (1) 3/8 hex head bolt, (1) 3/8 lock washer, and (1) 3/8 flat washer. Attach the mounting bracket to the rear mounting location using (1) 3/8 flat washer, (1) 3/8 lock washer, and (1) 3/8 hex nut FIG 3. Do not fully tighten at this time. Repeat step for passenger side.
4. With assistance take the bull bar and attach it to the mounting brackets using (4) 3/8 serrated flange bolts, and (4) 3/8 serrated flange nuts FIG 3. Do not fully tighten at this time.
5. Align and adjust bull bar as needed then fully tighten all hardware at this time. Torque all 3/8 hardware to 30-35 ft lbs

CARE INSTRUCTIONS

- REGULAR WAXING IS RECOMMENDED. DO NOT USE ANY TYPE OF POLISH OR WAX THAT MAY CONTAIN ABRASIVES
- STAINLESS STEEL PRODUCTS CAN BE CLEANED WITH MILD SOAP AND WATER. STAINLESS STEEL POLISH SHOULD BE USED TO POLISH SMALL SCRATCHES.
- GLOSS BLACK FINISHES SHOULD BE CLEANED WITH MILD SOAP AND WATER



Westing Automotive Products, Inc.
5200 N. Irwindale Ave. Suite 220
Irwindale, Ca. 91706

Thank You for choosing Westin products
For Additional installation assistance please call
Customer service (800) 793-7846
www.westingautomotive.com

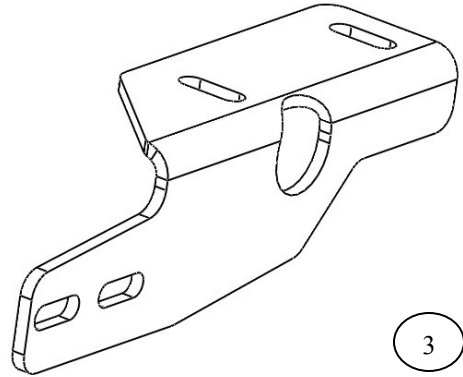
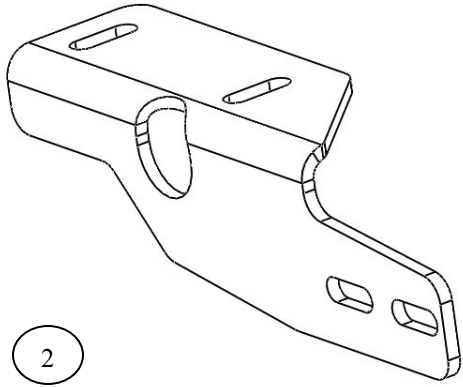

FIG 1

PASSENGER SIDE SHOWN

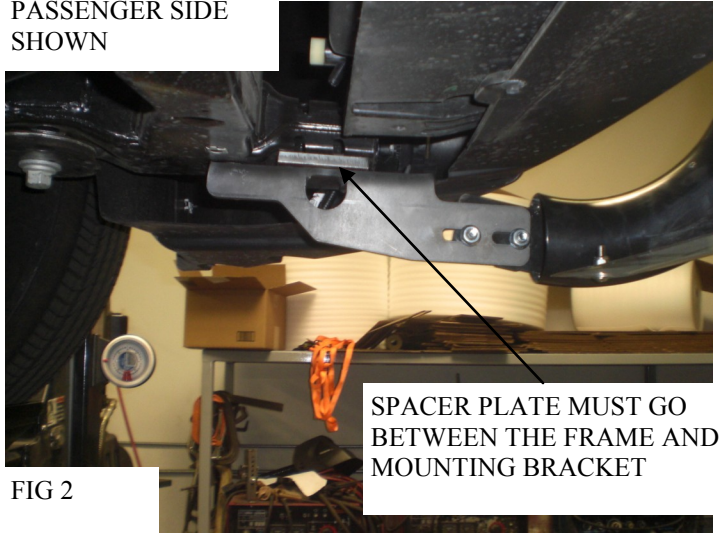

FIG 2

SPACER PLATE MUST GO BETWEEN THE FRAME AND MOUNTING BRACKET



FIG 3



INSTALLATION COMPLETE



Westing Automotive Products, Inc.
5200 N. Irwindale Ave. Suite 220
Irwindale, Ca. 91706

Thank You for choosing Westin products
For Additional installation assistance please call
Customer service (800) 793-7846
www.westinautomotive.com