



# INSTALLATION INSTRUCTIONS

AUTOMOTIVE PRODUCTS, INC.

## ULTIMATE BULL BAR

### APPLICATION:

2010-2017 Dodge Ram 2500/3500 HD

### PART NUMBER:

32-3550, 32-3555, 32-3550L, 32-3555L

ITEM	QUANTITY	DESCRIPTION	TOOLS NEEDED
1	1	ULTIMATE BULL BAR ASSEMBLY	9/16" SOCKET
2,3	2	MOUNTING BRACKET, DRIVER (2) AND PASSENGER (3)	9/16" WRENCH
4	8	3/8 BUTTON HEAD BOLTS	SWIVEL SOCKET
5	16	3/8 FLAT WASHERS	8" EXTENSION
6	8	3/8 LOCK WASHERS	ALLEN KEY
7	8	3/8 HEX NUTS	14MM SOCKET
8	4	3/8 BUTTON HEAD BOLTS (STAINLESS STEEL)	15MM SOCKET
9	8	3/8 FLAT WASHERS (STAINLESS STEEL)	13MM WRENCH
10	4	3/8 LOCK WASHERS (STAINLESS STEEL)	RATCHET
11	4	3/8 HEX NUT (STAINLESS STEEL)	TORQUE WRENCH
12	1	LED WIRING HARNESS (09-12000-1)	

**ANTI-SEIZE LUBRICANT MUST BE USED ON ALL STAINLESS STEEL FASTENERS TO PREVENT THREAD DAMAGE AND GALLING**

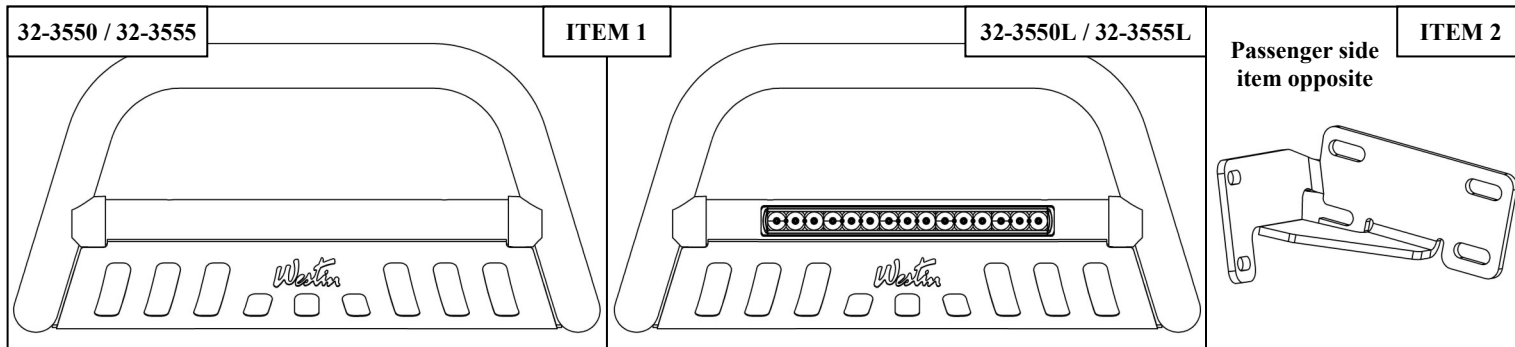

## PROCEDURE

1. Remove contents from box, verify if all parts listed are present and free from damage. Carefully read and understand all instructions before attempting installation.  
**Failure to identify damage before installation could lead to a rejection of any claim.**
2. Starting from the front of the vehicle remove the factory tow hooks and hardware and set the tow hooks aside. **Note:** The tow hooks cannot be re-used with this application. Assistance is recommended for removing the hardware attaching the tow hooks. With one person holding the backside of the factory bolts using an extension and a swivel socket, use the 14mm and 15mm sockets to remove hardware. **Note:** Size of sockets may differ between early models (2010-2013) and late models (2013-2017). If the vehicle is not equipped with tow hooks remove the (4) bolts located in the tow hook pocket on each side.
3. Take the drivers side mounting bracket and attach it to the frame where the tow hook previously was. Attach using (4) 3/8 button head bolts, (8) 3/8 flat washers, (4) 3/8 lock washers, and (4) 3/8 hex nuts. See **Figure 1**. Do not fully tighten at this time.



Westin Automotive Products, Inc.  
320 W. Covina Blvd  
San Dimas, Ca. 91773

Thank you for choosing Westin products  
for additional installation assistance please call  
Customer Service (800) 793-7846

4. Repeat **Step 3** for passenger side.
5. With assistance, align the bull bar to the mounting brackets and attach using (4) 3/8 button head bolts (stainless steel), (8) 3/8 flat washers (stainless steel), (4) 3/8 lock washers (stainless steel), and (4) 3/8 hex nuts. See **Figure 2**. Do not fully tighten at this time.
6. Align and adjust the bull bar as needed then fully tighten all hardware. Torque all 3/8 fasteners to 35-40 ft lbs. and all stainless fasteners to 25-30 ft lbs.
7. **For part number 32-3555L:** Refer to **Page 3** for wiring instructions. Loosen M8 hardware to adjust the LED light in bull bar or to remove it in order to replace it. See **Figure 3** for location of M8 hardware.



Figure 1

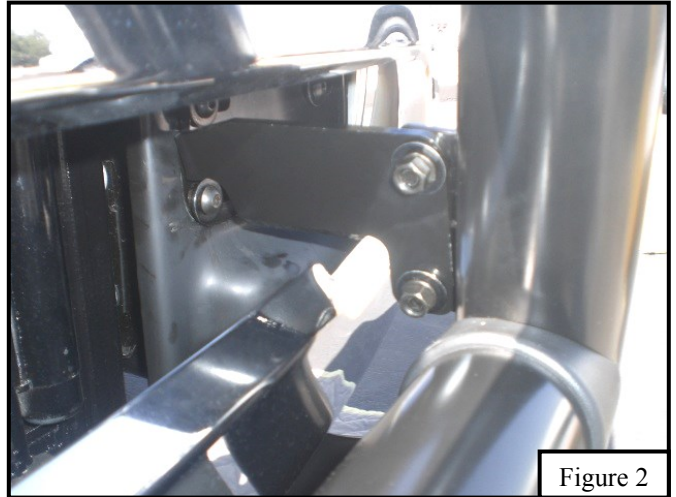
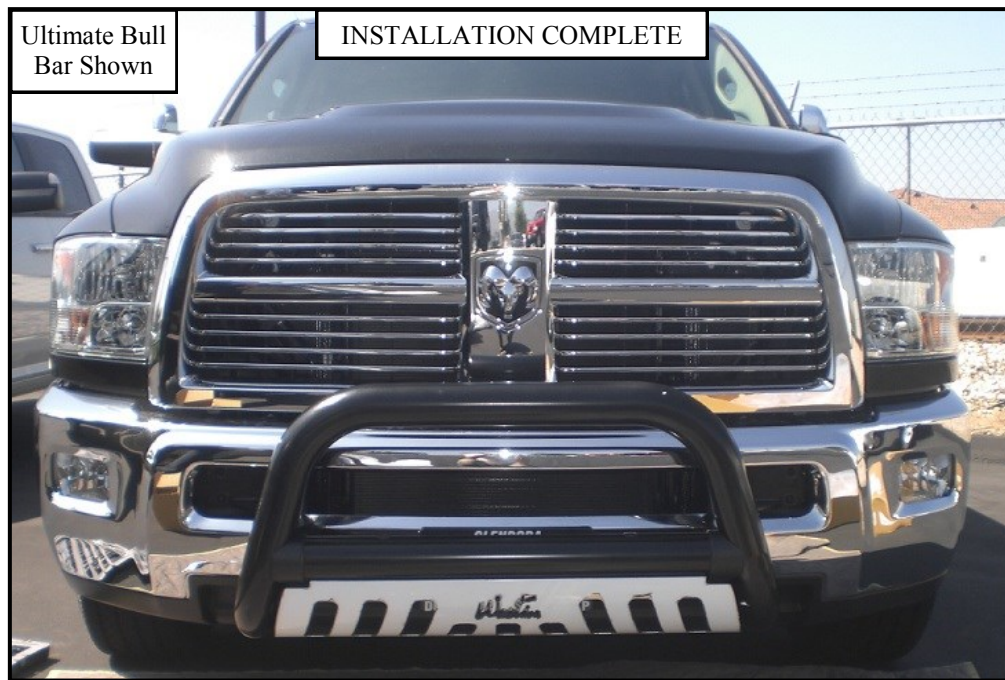

Figure 2



#### CARE INSTRUCTIONS

- REGULAR WAXING IS RECOMMENDED. DO NOT USE ANY TYPE OF POLISH OR WAX THAT MAY CONTAIN ABRASIVES.
- STAINLESS STEEL PRODUCTS CAN BE CLEANED WITH MILD SOAP AND WATER. STAINLESS STEEL POLISH SHOULD BE USED TO POLISH SMALL SCRATCHES.
- GLOSS BLACK FINISHES SHOULD BE CLEANED WITH MILD SOAP AND WATER.



Westin Automotive Products, Inc.  
320 W. Covina Blvd  
San Dimas, Ca. 91773

Thank you for choosing Westin products  
for additional installation assistance please call  
Customer Service (800) 793-7846

[www.westinautomotive.com](http://www.westinautomotive.com)

DATE: 3/15/17

## WIRING INSTRUCTIONS FOR 32-3555L:

WESTIN recommends using a professional for this installation.

### CAUTION:

1. Disconnect ground connection from battery (-) to avoid accidental short circuits before attempting to connect electrical wires.
2. When running wires, avoid areas of excessive heat, vibration, pinch or rotation when securing harness to vehicle.
3. Always use a fused (+) positive supply source.
4. This light becomes hot under continuous use. Do not remove or touch the casting for at least 30 minutes after the lamp has been turned off.

### Refer to Figure 4.

1. Locate wiring harness and mount the switch in a convenient location where it is easily accessible from the drivers seat.  
**Note:** *The switch will need to be removed from the wiring harness so that the rest of the harness can be routed from the engine bay to the cabin.*
2. Route the wiring harness wire, specifically the fuse and relay, from the positive battery terminal along the firewalls existing wire routes. **Note:** *Tape as necessary to correct slack.*
3. Secure the relay by either drilling or using a pre-existing bolt along the chassis that is not connected to any other wire.
4. Run the switch harness through the firewall preferably through the pre-existing rubber plug that is used to run the OEM wiring harness from the engine bay to fuse box. **Note:** *Reconnect the switch to the wiring harness.*
5. Place the LED plug wire along the fender chassis where it will not get pinched and away from any moving parts (fan, pulleys etc.).
6. Run the attached wire from the LED Light Bar as previously mentioned away from any moving parts.
7. Connect both ends of wiring connectors from LED light bar and wiring harness.
8. Re-connect battery terminals, attach the Red (+) wire to battery positive, and the black (-) wire to ground. **Note:** *Add dielectric grease (not supplied).*
9. Turn on the switch to make sure if the lamp works. If not, please check carefully if the wiring installation is correct.

M8 hardware attaches LED light onto bull bar.

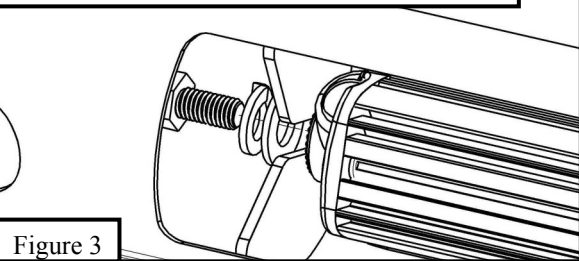

Figure 3

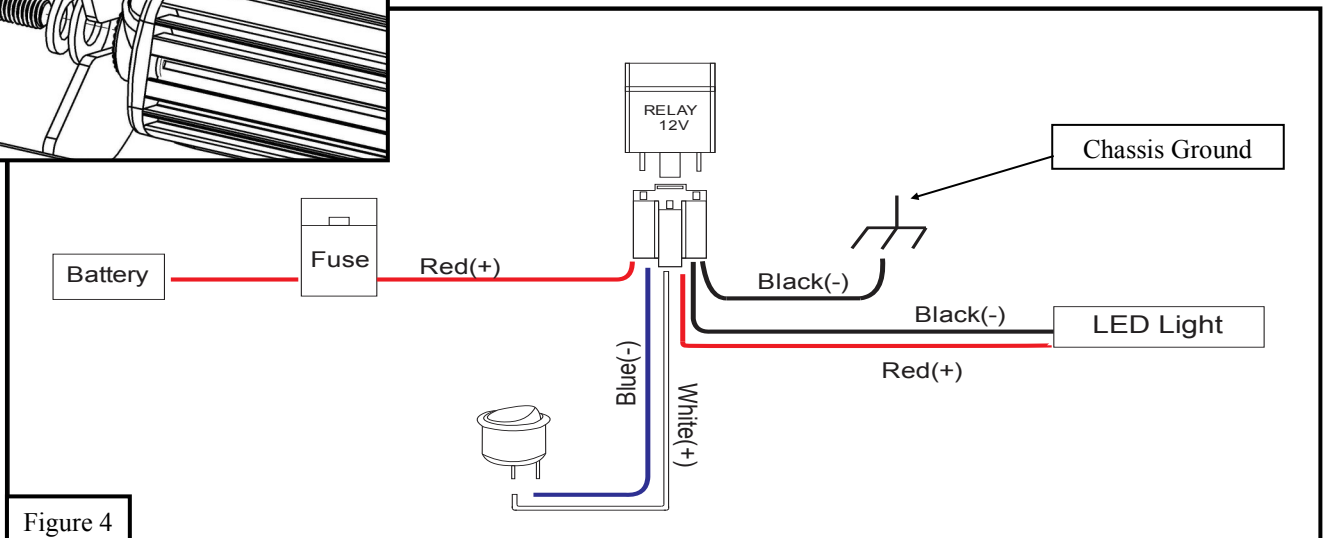

Figure 4



Westin Automotive Products, Inc.  
320 W. Covina Blvd  
San Dimas, Ca. 91773



SIGNATURE OF QUALITY

AUTOMOTIVE PRODUCTS, INC.



## WARNING



Failure to follow these instructions could lead to death, personal injury, and / or property damage.

### FASTENERS:

All Westin supplied fasteners must be utilized and installed in accordance with the installation instructions and apply torque to the specifications as defined. **DOUBLE CHECK ALL FASTENERS BEFORE INITIAL USE, AND PERIODICALLY IN THE FUTURE TO ENSURE PROPER FUNCTION AND SAFETY.**

### DRILLING:

Most Westin products do not require drilling for installation. If drilling is defined as required, use caution when drilling a vehicle. **FAILURE TO REVIEW AN AREA TO BE DRILLED MAY RESULT IN PERSONAL INJURY AND/OR INJURY TO OTHERS AS WELL AS VEHICLE DAMAGE.**

### EYE PROTECTION:

**ALWAYS WEAR SAFETY GLASSES OR GOGGLES DURING THE INSTALLATION PROCESS TO AVOID PERSONAL INJURY.**

### MAXIMUM TOWING/CARRYING CAPACITY:

The Westin Receiver Hitches will have a visible tow rating label affixed directly on the product. User should never exceed the vehicle manufacturers maximum tow and weight rating regardless of the capacity of the hitch. **FAILURE TO FOLLOW THESE GUIDELINES WILL VOID THE WESTIN WARRANTY AND MAY RESULT IN PERSONAL INJURY AND/OR INJURY TO OTHERS AS WELL AS VEHICLE DAMAGE.**



Westin Automotive Products, Inc.  
320 W. Covina Blvd  
San Dimas, Ca. 91773