



# SIDE MOUNT TOOL BOX MOUNTING INSTRUCTIONS

Please read these instructions first so you will be familiar with the procedures



**TOOL BOX MUST BE SECURELY MOUNTED TO PREVENT MOVEMENT OR SHIFTING.**

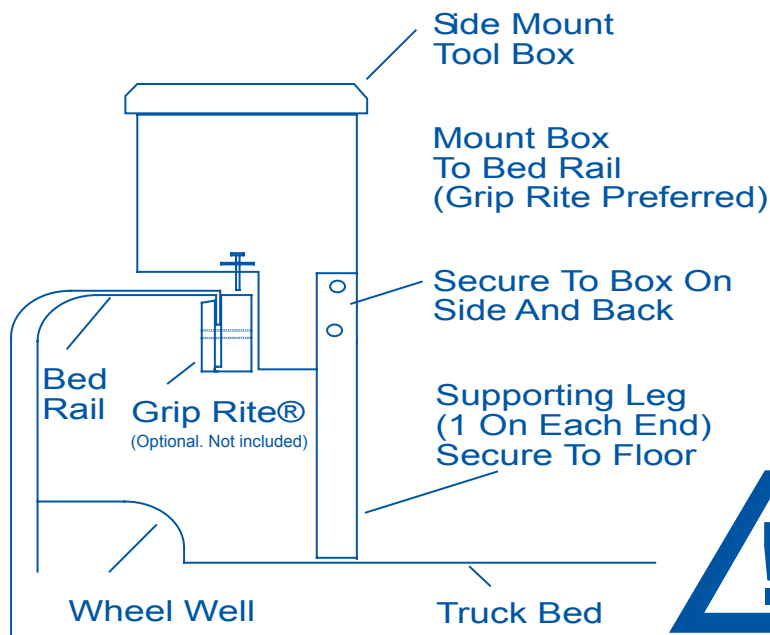

**NOTE:** If your truck has a bed liner, you will have to use these instructions as a guide only.

Due to the many differences in bed liner thickness and fit, longer fasteners are highly recommended.

You will need to ensure that your truck box is mounted securely to the truck, not the bed liner.



**WARNING:** Any leaking caused by unsealed holes in the box bottom will void the warranty. For steel products, any holes drilled during installation should be painted over or sealed to prevent rust from developing on exposed metal.

## MOUNTING WITH GRIP RITES® (Not included, sold separately. Grip Rites® not required for proper installation)

1. Place box on top of truck bed rail, and move to desired position.
2. Support the back of the box while mounting to the truck.
3. Secure (attach) the box to the top of the truck bed rail. Most users prefer to use optional Grip Rite® no hole mounts. (Instructions follow):
  - a. Measure for location then mount Grip Rites® to the truck bed rail as shown in the illustration and on the Grip Rite® package.
  - b. Set the toolbox on the bed rail and sight down the front to determine where the Grip Rite® will line up under the front lip.
  - c. Measure from the front of the toolbox to the sighted line where the Grip Rite® lines up.
  - d. Transfer the dimension just taken less 1/4" (for inside compensation) to the mounting surface inside the toolbox.
  - e. The Grip Rite® mounts have holes spaced 3 3/8" apart, and should be marked as such along the line just made. These will be the locations to drill the holes in your toolbox.
  - f. Drill to a finish hole size of 3/8" at the locations just indicated.
  - g. Finish mounting the toolbox to the Grip Rites® using the screws and washers provided.

4. Position the support leg against the back and side of the tool box.
5. Secure the support leg to the toolbox using the hardware provided. Be sure to secure the leg on the back and side surfaces of the toolbox.
6. Secure the support leg to the bed of the truck.
7. Repeat for the support leg on the opposite end.

## MOUNTING WITH SCREWS

1. Place box on top of truck bed rail, and move to desired position.
2. Support the back of the box while mounting to the truck.
3. On opposing ends of tool box drill 1/4" hole in top lip of tool box 1" from end of box, being sure to drill into truck body. Secure with 3/8" sheet metal screws. Alternatively, self-tapping screws can be used for mounting. Secure no more than one screw at each end of box. **USING MORE THAN ONE SCREW ON EACH END OF TOOL BOX WILL VOID THE WARRANTY** for the tool box.
4. Follow steps 4 through 7 listed above.

Check us out on-line!  
[www.DawsBetterBuilt.com](http://www.DawsBetterBuilt.com)



For Customer Service  
or warranty information  
call 1-800-366-8269

DAWS MANUFACTURING COMPANY, INC. • 8811 GROW DRIVE, PENSACOLA, FL 32514

200912