



BLUE OX®

BX1699

**2011-2012 Cadillac Escalade Platinum Hybrid
Installation Instructions**

Serial Number

Please read BOTH these Installation Instructions and the General Towing Instructions before attempting to install or operate this equipment.

- Blue Ox® towing products and accessories are intended to be installed by Blue Ox® Dealers who are familiar with our products and have the equipment and knowledge to do “fit work.” When necessary, Blue Ox® Dealers can be found at www.blueox.com or by contacting our Customer Care Department at (402) 385-3051.
- Many Blue Ox® Baseplates are designed to use existing holes and hardware to mount the baseplate to the towed vehicle. Even though bolts are there, do not assume they are adequate for baseplate mounting. Always use hardware supplied in the hardware kit or existing hardware specified in the Baseplate Towing Installation Instructions.

Attachment Tab Height: 17 1/2”
Attachment Tab Width: 23 1/4”

Bolt Torque Specifications
Torque in Foot-Pounds for Metric Bolts

Bolt Size	Grade 8.8	Grade 10.9
6MM	6	8
8MM	16	22
10MM	31	40
12MM	54	70
14MM	89	117

Confirm the towability and pre-towing procedures for your vehicle with the owner’s manual or contact the vehicle’s manufacturer for specific towing procedures.

Bolt Torque Specifications
Torque in Foot-Pounds for Inch Bolts

Bolt Size	Grade 5	Grade 8
1/4”	10	14
5/16”	19	29
3/8”	33	47
7/16”	54	78
1/2”	78	119
5/8”	154	230



If the front of your vehicle looks different than this, call us at (402) 385-3051.

! WARNING

Failure to read and follow these instructions could result in separation of the towed vehicle from the tow bar, causing property damage, loss of towed vehicle, personal injury or death.



BLUE OX®

BX1699

2011-2012 Cadillac Escalade Platinum Hybrid Installation Instructions

Tools Required

7MM Socket
10MM Socket
3/4" Socket
3/4" Wrench

Flat Screw Driver
Drill
15MM Socket
Tape Measure

1-1/2" Hole Saw
Large Vice Grip
17/32" Drill Bit
Utility Knife

Torque Wrench
7/16" Socket
7/16" Wrench
Loctite® RED

ITEM NO.	PART NUMBER	DESCRIPTION	QTY.
1	61-6934	WLDMT, BP, BX1699	1
2	62-3469	ATT TAB ASSY, REM, SF/LB, 1 HOLE	2
3	202-0102	1/4-20 HEX NYL NUT, ZP	3
4	201-0050	1/4-20 X 3/4 HEX BOLT, GRD. 5, ZP	3
5	201-0011	1/2-13 X 1 1/4 HEX BOLT GRD. 5, ZP	8
6	202-0094	1/2-13 HEX NYL. INS LOCK NUT	8
7	102-7245	BREAKAWAY BRKT, BX1699	1

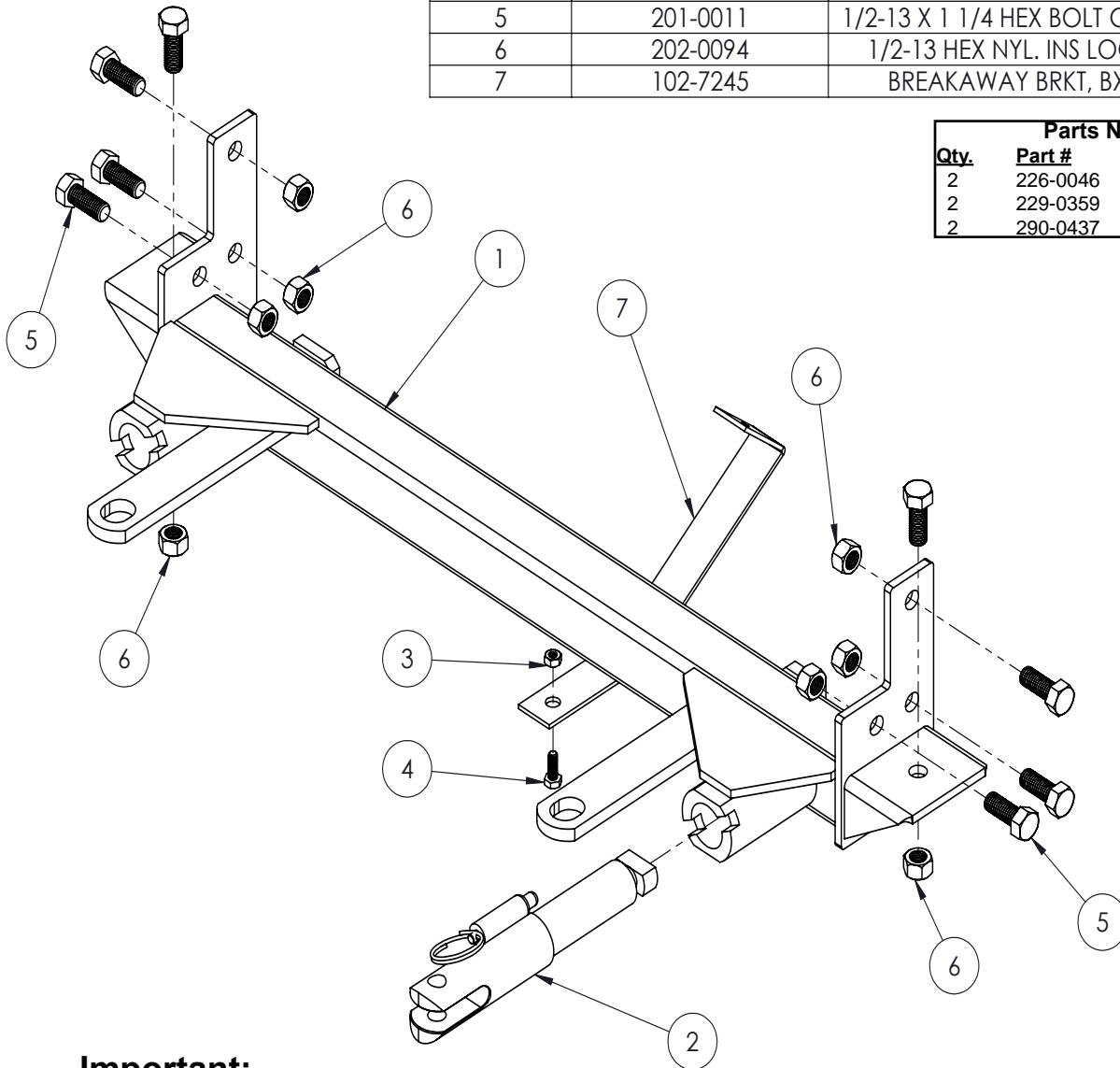

Parts Not Pictured:

Qty.	Part #	Description
2	226-0046	Baseplate Safety Cables
2	229-0359	Quicklink, 3/8, ZP
2	290-0437	Cap Plug, Black

Important:

Use only genuine factory replacement parts on your baseplate. Do **NOT** substitute homemade or non-typical parts. If a bolt is lost or in need of replacement, for your safety and the preservation of your baseplate, be sure to use a replacement bolt of the same grade (In most cases it will be Grade 5, please reference the parts list above). Replacement parts may be ordered through your nearest Blue Ox® Dealer or Distributor. Failing to follow and/or altering these installation instructions in either installation or required equipment will void the manufacturer's warranty.



BLUE OX

BX1699

2011-2012 Cadillac Escalade Platinum Hybrid Installation Instructions

Vehicle Weight: Be sure to confirm the weight of your individual vehicle before towing. Some models, depending on options and load, may exceed the weight rating of specific tow bars. Always insure both your tow bar and hitch are adequately rated for the vehicle's overall weight.

Tow Bar Adapters are NOT to be used with vehicles weighing over 5,000 lbs.

Installation Notes: The fascia, radiator cover and lower bumper support are removed and reinstalled during installation of the baseplate. Drilling is required. Trimming of the fascia is required.

The dimensional variations between otherwise identical vehicles can be considerable. While the baseplate was designed for easy installation, it may be necessary to tailor the baseplate slightly to compensate for auto manufacturer's tolerances. These minor adjustments may include filing a hole slightly, bending electrical rods or bending end plates.

The BX8848 Diode Wiring Kit is recommended for this vehicle.

Handling of some cosmetic parts when installing this product may require the use of protective covers, rags, specialty tools, etc. to prevent damage.

Do not use the towed vehicle for storing luggage, equipment, etc. This may cause you to exceed the towing capacity of the tow bar, baseplate, and its accessories.



1. Remove nine push pins from the radiator cover on the top side of the fascia. Set radiator cover and push pins aside to be reinstalled later.



2. Using a 10MM socket, remove six bolts from the fascia. Set bolts aside to be reinstalled later. Carefully remove fascia and set aside to be reinstalled later.



BLUE OX®

BX1699

2011-2012 Cadillac Escalade Platinum Hybrid Installation Instructions



3. In front of the tire, with a 7MM socket, remove 2 bolts (white arrows). Also remove 2 push pins in front of the tire (gray arrows). Do this to both sides. Set bolts and push pins aside to be reinstalled later.

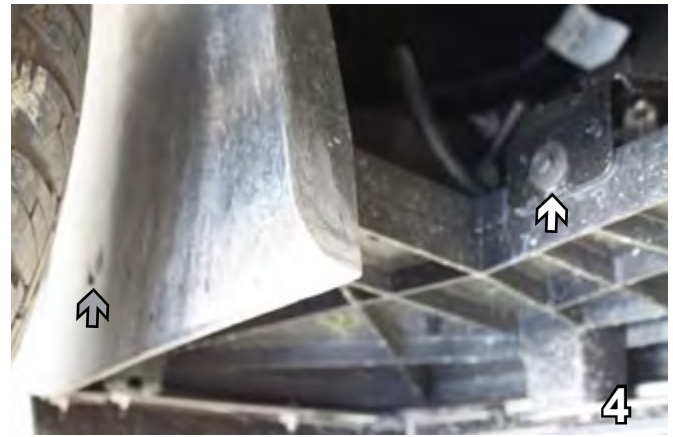

4. Using a 10MM socket, remove one bolt located underneath the fascia, directly in front of the tire (white arrow). Also, directly in front of the tire, remove 1 push pin (gray arrow). Do this to both sides. Remove lower bumper support and set lower bumper support, bolts and push pins aside to be reinstalled later.

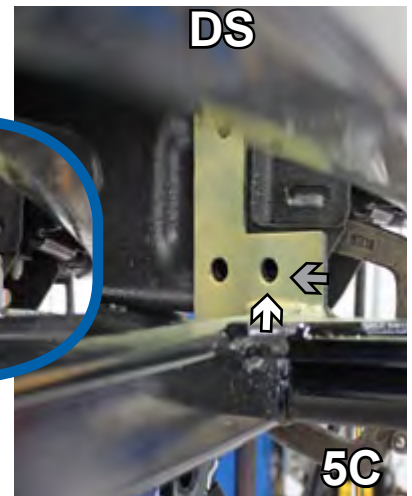
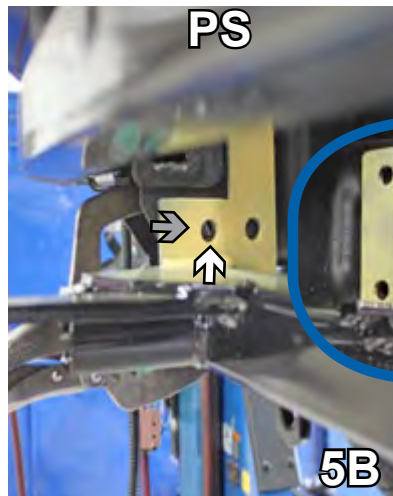

5. Using existing front holes in frame and baseplate as a guide, slide the baseplate up to frame rail as shown in picture 5A. There are existing bolt holes to align baseplate (2 on driver's side, 1 on passenger's side). Insure baseplate is level. Clamp with large vise grips. Should existing bolt holes need to be drilled to accommodate baseplate, use 17/32" drill bit to accommodate the 1/2-13 x 1 1/4 hex bolts. Start with the front bolts referenced in pictures 5B and 5C (white arrows). Yellow is used on this baseplate for demonstrative purposes only.

Insert 1/2-13 x 1 1/4 hex bolts into the front holes of each side of the baseplate (gray arrows) with 1/2-13 hex nyl. ins. locking nut. Tighten bolts with Loctite Red.

BE SURE TO USE LOCTITE® RED ON ALL BOLTS BEFORE TIGHTENING. TIGHTEN ALL BOLTS ACCORDING TO THE TORQUE CHART ON THE FRONT PAGE OF THESE INSTRUCTIONS OR ON PAGE 3 OF THE BASEPLATE TOWING GENERAL INSTRUCTIONS.



BLUE OX®

BX1699

2011-2012 Cadillac Escalade Platinum Hybrid Installation Instructions



6. At the bottom of the baseplate, drill with a 17/32" drill bit to accommodate the 1/2-13 x 1 1/4 hex bolt. Do this on both sides - confirm baseplate remains level. Insert 1/2-13 x 1 1/4 hex bolts into holes on each side of the baseplate with 1/2-13 hex nyl. ins. locking nuts. Tighten bolts with Loctite Red.



7. Drill remaining 2 holes on side plates of the baseplate with a 17/32" drill bit. Do this on both sides. Insert 1/2-13 x 1 1/4 hex bolts into holes on each side of the baseplate with 1/2-13 hex nyl. ins. locking nuts. Tighten bolts with Loctite Red.



8. Using a utility knife, cut out chrome webbing on the front of the fascia to accommodate baseplate. Do this on both sides.



2011-2012 Cadillac Escalade Platinum Hybrid Installation Instructions



9A



9B



9C

9. After chrome has been trimmed, on backside of fascia, trim plastic with utility knife as shown in 9A. Turn fascia over and trim second layer of plastic from fascia with utility knife (9B). Completed trimming shown in 9C.



10

10. **Optional:** To mount electrical connector (not provided), in the center, underneath the license plate frame at bottom of the fascia, with a 1 1/2" hole saw, drill through the bottom of the fascia frame as shown above. Insert electrical adapter. Using the adapter as a template, drill additional holes on each side to attach with the hardware.

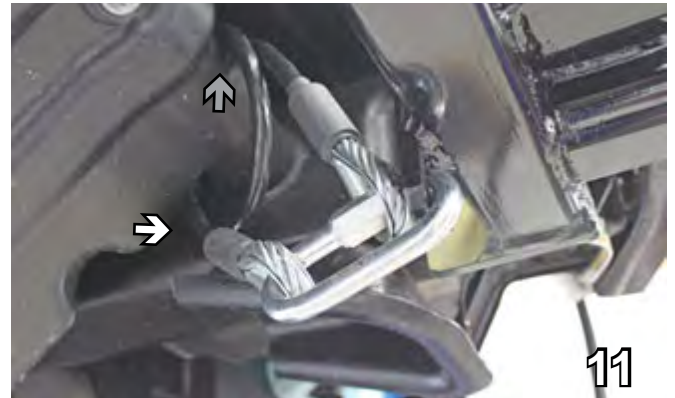

11

11. Attach permanent baseplate safety cables to the provided convenience link on the baseplate (white arrow) The photo above shows the recommended installation of the cables to frame of vehicle (gray arrow). Additional options may interfere with suggested mounting; in this case, secure the cables to a solid piece of the frame as described in the instructions included with the permanent baseplate safety cables. Be sure the safety cables do not rub against any hoses or moving parts. Do this to both sides of the vehicle.



12

12. Reinstall lower bumper support, fascia, and radiator cover with existing bolts and push pins.

When using power drills be aware of the dangers of torque and drill bit length.



BLUE OX®

BX1699

2011-2012 Cadillac Escalade Platinum Hybrid
Installation Instructions



13. **Optional:** With a 15MM socket, remove the driver's side bolt from the bellypan. Attach breakaway bracket into existing hole on bellypan using existing bolt (13A). Attach breakaway bracket to fascia with 1/4-20 x 3/4 hex bolt and 1/4-20 hex nyl. nut (13B).

DEALER or INSTALLER:
Be certain the user receives the
instruction sheets for their products.

Be sure that **ALL** electrical connections
are plugged in properly and functioning
BEFORE installing the fascia.



BX1699

2011-2012 Cadillac Escalade Platinum Hybrid Installation Instructions

Install the tow bar and safety cables according to the instructions provided in their packages. When demonstrating this to the customer, be sure to include all the contents and packages.

Do **NOT** substitute other devices if the tow bar pins and clips are misplaced.



Shown with removable tabs installed.



Shown without removable tabs installed.

If the baseplate is in an accident, it must be replaced. DO NOT use it again! An accident can cause unseen damage and using it again could result in more damage or serious injury. DO NOT use the baseplate if it is damaged or missing parts.

CUSTOMER SERVICE COMMITMENT

Blue Ox is committed to providing you with exceptional customer care throughout your lifetime with our products. Our team is here to assist you with any questions you may have regarding the performance of your product. Simply call (402) 385-3051 and you can speak with our customer care team.

Additionally, please visit our website to see which rallies our Destination America team will be attending. For a nominal fee, our service technician will service your towing system to ensure it's in proper working condition. Also, as a commitment to our customers, should you visit our factory, you can stay at our full service Blue Ox campground at no charge along with enjoying a factory tour.

Again, thank you for being our customer and for the confidence you have shown in the performance of our products. It is because of customers like you we enjoy the success we have today.



© 2011 Blue Ox
One Mill Road, Industrial Park
Pender, Nebraska 68047
Phone: (402) 385-3051 • Fax: (402) 385-3360
www.blueox.com