



## BX1948 Installation Instructions 2002-05 Dodge Ram 1500

Serial No.

The front metal bumper is removed for baseplate installation. Holes need to be drilled. The BX8869 is available for the base plate. Attachment tabs are 24 inches center to center and a height of 24 inches.



1. Using the 18MM socket, remove the four metric bolts from the back side of front bumper. Pull front metal bumper forward and set aside.

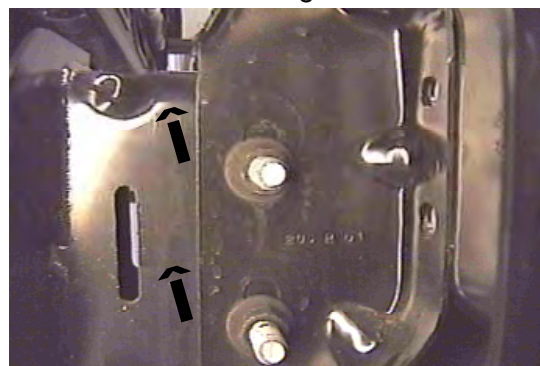

2. Mark both brackets height on frame. Remove the two metric nuts and bolts from the frame ends with the 18MM socket, both sides. Replace with items 2, 4, 5, and 6, according to drawing on last page and tighten. **Be sure and use loctite on all bolts before tightening.**

3. Align the two lower holes on the baseplate to the existing lower holes on bumper bracket according to drawing on last page. Insert item 3 and tighten items 5 and 6 to back side of bracket, both sides. The upper existing hole on the bumper bracket will need to be reamed out and the top inside hole on the baseplate will need to be drilled with the 17/32" drill bit. Install items 3, 5, and 6 into these holes and tighten. **Be sure and use loctite on all bolts before tightening.**



4. The plastic insert in the middle of the metal bumper will need to be removed for proper fit or plastic can be trimmed. Reinstall metal bumper using existing nuts.
5. The dimensional variations between otherwise identical cars can be considerable. While the location and size of the holes in the baseplate were designed to allow for easy installation, it may be necessary to file a hole slightly to allow a bolt to clear.
6. Install the tow bar and safety cables according to the instructions included in their packages.
7. Do **not** substitute other devices if the tow bar pin and clip are lost.

8. **DEALER OR INSTALLER: BE CERTAIN THE USER RECEIVES THE INSTRUCTION SHEET.**



## Tools Required

18MM Socket  
3/4" Socket

Loctite Red  
Vise Grips

17/32" Drill Bit

## Parts List

Ref. No.	Qty.	Part No.	Description
1	1	61-5695	Weldment, Base Plate, BX1948
2	4	201-0581	1/2-13 x 4 Hex Bolt, Grd. 5, ZP
3	8	201-0011	1/2-13 x 1 1/4 Hex Bolt, Grd. 5, ZP
4	8	203-0005	1/2 Flat Washer, ZP
5	12	203-0012	1/2 Lock Washer, ZP
6	12	202-0005	1/2-13 Hex Nut, ZP
7	2	201-0553	1/4-20 x 1/2 Hx. Wshd, Type F Screw
8	2	202-0047	#10-32 Hex Nut
9	2	203-0054	#10 Lock Washer
10	2	201-0192	#10-32 x 1/2 Slot, Rd. Hd. Screw
11	2	101-5822	Adapter, 4 Way Connector
	2	226-0049	Baseplate Safety Cable, 36" CL IV (Not Shown)
	4	229-0512	Quicklink, 1/2, ZP (Not Shown)

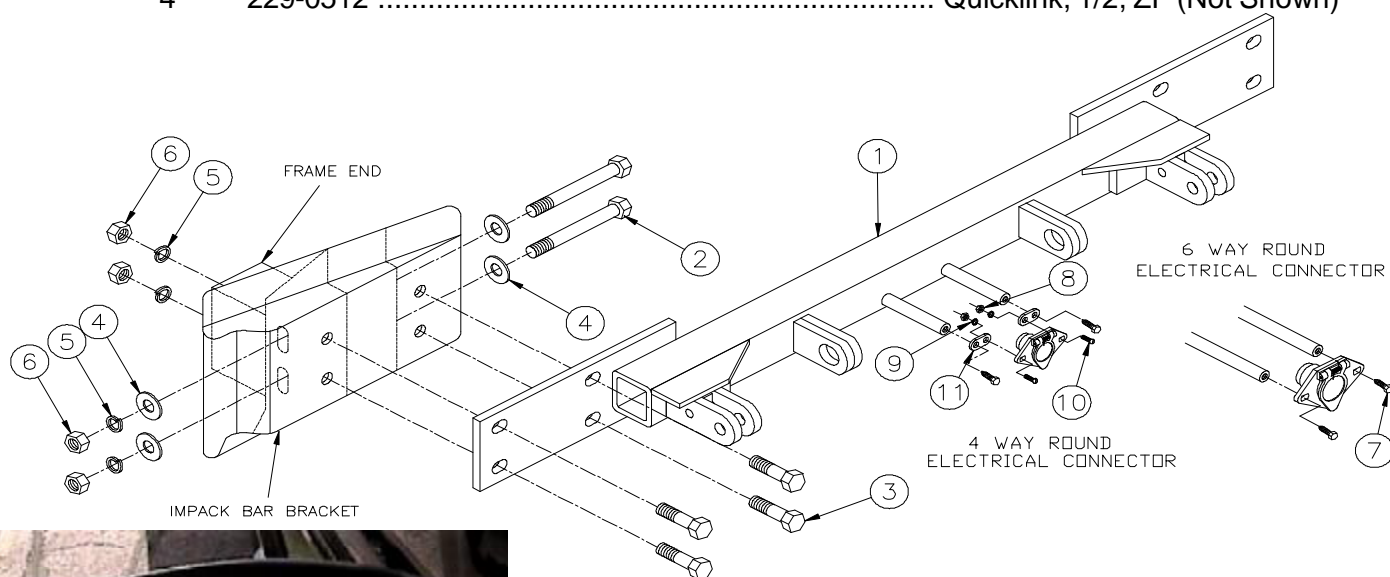

*Location for the BX8869,  
view of driver's side tail  
light assembly.*

**IMPORTANT:** Use only genuine factory replacement parts on your Base Plate. Do not substitute homemade or nontypical parts. If a bolt is lost or in need of replacement, for your safety and the preservation of your Base Plate, be sure to use a replacement bolt of the same grade (Usually Grade 5, refer to parts list). Repair parts may be ordered through your nearest **Blue Ox** dealer or distributor.