

Serial Number

Please read BOTH these Installation Instructions and the General Instructions before attempting to install or operate this equipment.

- Blue Ox® towing products and accessories are intended to be installed by Blue Ox® Dealers who are familiar with our products and have the equipment necessary and knowledge to do "fit work". When necessary Blue Ox® Dealers can be found at www.blueox.us or by contacting our Customer Care Department at (402) 385-3051 or toll free (888) 425-5382.
- Many Blue Ox® Baseplates are designed to use existing holes and hardware to mount the baseplate to the towed vehicle. Even though bolts are there, do not assume they are adequate for baseplate mounting. Always use hardware supplied in the hardware kit and existing hardware specified in the Baseplate Installation Instructions.

Attachment Tab Height: 14"
Attachment Tab Width: 24"

Bolt Torque Specifications
Torque in Foot-Pounds for Metric Bolts

Bolt Size	Grade 8.8	Grade 10.9
6MM	6	8
8MM	16	22
10MM	31	40
12MM	54	70
14MM	89	117

Confirm the towability and pre-towing procedures for your vehicle with the owner's manual or contact the vehicle's manufacturer for specific towing procedures.

Bolt Torque Specifications
Torque in Foot-Pounds for Inch Bolts

Bolt Size	Grade 5	Grade 8
1/4"	10	14
5/16"	19	29
3/8"	33	47
7/16"	54	78
1/2"	78	119
5/8"	154	230



! WARNING
Failure to read and follow these instructions could result in separation of the towed vehicle from the tow bar, causing property damage, loss of towed vehicle, personal injury or death.

BX2229 2002-05 Honda Accord

(Including LX, EX, DX)

Installation Instructions

Parts List

Ref. No.	Qty.	Part #	Description
1	1	61-5863	Weldment, Baseplate, BX2229
2	1	61-5288	Weldment, 1/2-13 DS, Nutplate
3	1	61-5289	Weldment, 1/2-13, PS, Nutplate
4	4	61-5208	Weldment, 3/8-16, Nutplate, with Wire
5	2	62-3469	Attachment Assembly, SF/LB (R)
6	4	201-0051	1/2-13 x 1 1/2" Hex Bolt, Grade 5, ZP
7	4	203-0012	1/2" Lock Washer, ZP
8	6	201-0368	3/8-16 x 1 1/4" Hex Bolt, Grade 5, ZP
9	2	203-0003	3/8" Flat Washer, ZP
10	6	203-0010	3/8" Lock Washer, ZP
11	2	202-0003	3/8-16 Hex Nut, ZP
12	2	201-0553	1/4-20 x 1/2" Hx. Wshd, Type F Screw
13	2	202-0047	#10-32 Hex Nut
14	2	203-0054	#10 Lock Washer
15	2	201-0192	#10-32 x 1/2" Slot, Rd. Hd. Screw
16	2	101-5822	Adapter, 4 Way Connector
17	1	201-0655	6MM-1" x 30MM Hex Bolt, Grade 8.8, ZP
18	1	203-0008	1/4" Lock Washer, ZP
19	1	203-0001	1/4" Flat Washer, ZP
	2	226-0046	Baseplate Safety Cable, 36" CL III (Not Shown)
	2	229-0359	Quicklink, 3/8, ZP (Not Shown)
	2	290-0437	Cap Plug, Black (Not Shown)

Tools Required

8MM Socket
10MM Socket
12MM Socket
13MM Socket
13/32" Drill Bit
Vise Grips
LOCTITE Red

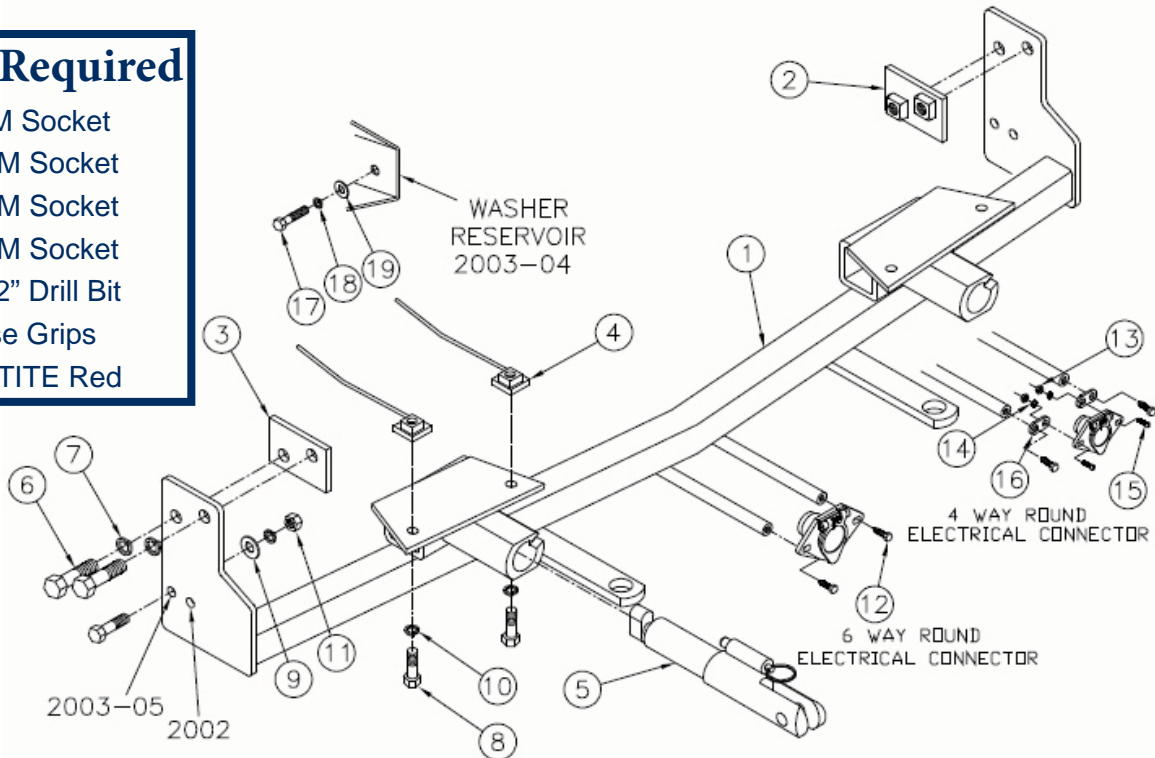

Important:

Use only genuine factory replacement parts on your baseplate. Do NOT substitute homemade or non-typical parts. If a bolt is lost or in need of replacement, for your safety and the preservation of your baseplate, be sure to use a replacement bolt of the same grade (In most cases it will be Grade 5, please reference the parts list above). Replacement parts may be ordered through your nearest Blue Ox® Dealer or Distributor, or call our Customer Care Team at (402)385-3051. Failing to follow and/or altering these installation instructions in either installation or required equipment will void the manufacturer's warranty.

BX2229 2002-05 Honda Accord (Including LX, EX, DX) Installation Instructions

Removable Tabs:

Due to the design of the removable tabs, the RangeFinder II tow bar can not be used. Adapters, except for the BX8833 and the BX88151, can not be used with this baseplate.

Instructions:

The front fascia, metal bumper, and head light assemblies are removed and reinstalled for the baseplate installation. Drill is required.

The dimensional variations between otherwise identical vehicles can be considerable. While the baseplate was designed for easy installation, it may be necessary to tailor the baseplate slightly to compensate for auto manufacturer's tolerances. These minor adjustments may include filing a hole slightly, bending electrical rods or bending end plates.

The BX8869 Bulb and Socket Wiring Kit is available for this vehicle.



1. Remove two pushpins from the top side of the grille. Set the pushpins aside to be reinstalled later.



2. Using the 8MM socket, just behind the fascia's upper corner, remove one metric bolt. Set the bolt aside to be reinstalled later. Do this to both sides of the vehicle.

BX2229
2002-05 Honda Accord
(Including LX, EX, DX)
Installation Instructions

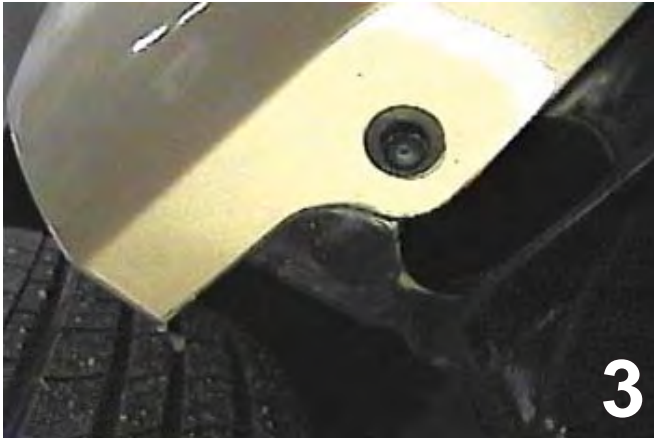

3. Using the 10MM socket, remove the metric bolt from the bottom side of the fascia corner. Set the metric bolt aside to be reinstalled later. Do this to both sides of the vehicle.

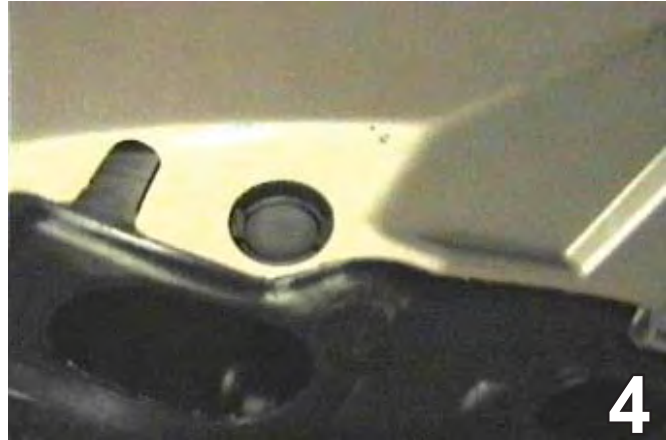

4. Remove six pushpins from the bottom side of the fascia. Set the pushpins aside to be reinstalled later.



5. Using the 10MM socket, remove five bolts under and one on the outside of the headlight assemblies, unplug and set aside to be reinstalled later. Set metric bolts aside to be reinstalled later. Do this to both sides of the vehicle.



6. **2002 Models:** Hold the baseplate in place, clamp with the vise grips, and center to the bottom of the metal bumper.

2003-05 Models: Hold the baseplate sides to align with the front edge of the frame end. Mark and drill all holes into the frame using the 13/32" drill bit and the 17/32" (upper holes) drill bit. Do this to both sides of the vehicle.

BX2229
2002-05 Honda Accord
(Including LX, EX, DX)
Installation Instructions



7. Using the 12MM socket, remove metric bolts from the top and bottom of metal bumper and set metal bumper aside to be reinstalled later. Set baseplate in place with drilled holes. Insert the 3/8-16 nut plates into the frame end and start the 3/8-16 x 1 1/2" hex bolts and the 3/8" lock washers, do **NOT** tighten. Slide the metal bumper between baseplate and frame to align with existing holes. Use the 3/8" flat washer between the metal bumper and the baseplate to level as needed, vehicles may vary. Tighten the 8MM-1.25 x 30MM hex bolts, 8MM lock washers, and the 3/8" flat washers on the top side and existing bolts on the bottom side. **BE SURE TO USE LOCTITE Red on ALL bolts.**

Install the tow bar and safety cables according to the instructions included in their packages.

Do not substitute other devices if the tow bar pin and clip are lost.

DEALER OR INSTALLER: BE CERTAIN THE USER RECEIVES THE INSTRUCTION SHEETS.



8. Reinstall the metal bumper, align the 3/8-16 nutplate inside the metal bumper with the drilled 13/32" hole and tighten the 1/2" lock washer, 3/8" lock washer. for upper supports.



9. Reinstall the fascia and headlight assemblies. Some trimming may be required.

2003-04 Models: The front washer reservoir bolt plastic will need to be trimmed before the installation . Install the washer reservoir. Be sure to reconnect all electrical and fluid lines.

BX2229
2002-05 Honda Accord
(Including LX, EX, DX)
Installation Instructions



Shown with Removable Tabs Installed.

CUSTOMER SERVICE COMMITMENT

Blue Ox is committed to providing you with exceptional customer care throughout your lifetime with our products. Our team is here to assist you with any questions you may have regarding the performance of your product. Simply call 1-800-228-9289 and you can speak with our customer care team.

Additionally, please visit our website to see which rallies our Destination America team will be attending. For a nominal fee, our service technician will service your towing system to ensure it's in proper working condition. Also as a commitment to our customers, should you visit our factory you can stay at our full service Blue Ox campground at no charge along with enjoying a factory tour.

Again thank you for being our customer and for the confidence you have shown in the performance of our products. It is because of customers like you we enjoy the success we have today.

If the baseplate is in an accident, it must be replaced. DO NOT use it again! An accident can cause unseen damage and using it again could result in more damage or serious injury. DO NOT use the baseplate if it is damaged or missing parts.



© 2006, 07, 08, 09 Blue Ox
One Mill Road, Industrial Park
Pender, Nebraska 68047
Phone: (402) 385-3051
Toll Free: (888) 425-5382
Fax: (402) 385-3360
www.blueox.us