



BX3232
 2007 Pontiac Solstice
 (No Turbo)
 Installation Instructions

Serial Number

Please read BOTH these Installation Instructions and the General Towing Instructions before attempting to install or operate this equipment.

1. Blue Ox® towing products and accessories are intended to be installed by Blue Ox® Dealers who are familiar with our products and have the equipment and knowledge to do “fit work.” When necessary, Blue Ox® Dealers can be found at www.blueox.us or by contacting our Customer Care Department at (888) 425-5382.

Attachment Tab Height: 14”
 Attachment Tab Width: 18”

2. Many Blue Ox® Baseplates are designed to use existing holes and hardware to mount the baseplate to the towed vehicle. Even though bolts are there, do not assume they are adequate for baseplate mounting. Always use hardware supplied in the hardware kit or existing hardware specified in the Baseplate Towing Installation Instructions.

Bolt Torque Specifications
 Torque in Foot-Pounds per Metric Bolts

Bolt Size	Grade 8.8	Grade 10.9
6MM	6	8
8MM	16	22
10MM	31	40
12MM	54	70
14MM	89	117

Confirm the towability and pre-towing procedures for your vehicle with the owner’s manual or contact the vehicle’s manufacturer for specific towing procedures. You can also contact REMCO for additional information at 1(800)228-2481.

Bolt Torque Specifications
 Torque in Foot-Pounds per Inch Bolts

Bolt Size	Grade 5	Grade 8
1/4”	10	14
5/16”	19	29
3/8”	33	47
7/16”	54	78
1/2”	78	119
5/8”	154	230



! WARNING

Failure to read and follow these instructions could result in separation of the towed vehicle from the tow bar, causing property damage, loss of towed vehicle, personal injury or death.

BX3232

2007 Pontiac Solstice (No Turbo)

Installation Instructions

Parts List

Ref. No.	Qty.	Part #	Description
1	1	61-6428	WLDM'T, BASEPLATE, BX3232
2	3	61-5208	WLDT, NUT PLT, 1/4X1X1, 3/8 BLT WIR
3	2	201-0368	3/8-16 X 1 1/4 HEX HEAD BOLT,GRD. 5
4	1	201-0440	3/8-16 X 1 1/2 HEX BOLT, GRD.5, ZP
5	3	203-0010	3/8 LOCK WASHER, ZP
6	6	203-0003	3/8 FLAT WASHER, ZP
7	1	201-0410	10MM-1.5 X 35MM HEX BOLT GRD.8.8 ZP
8	3	203-0104	10MM LOCK WASHER, ZP.
9	2	202-0111	10MM-1.5 HEX NUT ZP
10	2	201-0448	1/4-20 X 1 1/2 HEX BOLT GRADE 5 ZP.
11	5	203-0008	1/4 LOCK WASHER, ZP
12	5	203-0001	1/4 FLAT WASHER, ZP
13	2	202-0069	1/4-20 HEX FLANGE WHIZ LOCK NUT, ZP
14	2	201-0192	10-32 X 1/2 SLOT, RD. HD. SCREW
15	2	203-0054	#10 LOCK WASHER
16	2	202-0047	#10-32 HEX NUT
17	2	101-5822	ADAPTER, 4 WAY CONNECTOR
18	1	101-6841	ELECTRICAL BRACKET, 45 DEGR.
19	2	62-3469	ATT TAB ASSY, REM, SF/LB, 1 HOLE
	2	226-0047	BASEPLATE SAFETY CABLE, 48" CL III
	2	229-0359	QUICKLINK, 3/8, ZP
	2	290-0437	RECEIVER, CAP PLUG (BLK) (NOT SHOWN)

Tools Required

- | | |
|--------------------|----------------|
| 7/16" Socket | Hack Saw Blade |
| 9/16" Socket | 13MM Socket |
| 13/32" Drill Bit 1 | 15MM Socket |
| 7MM Socket | 6MM Socket |
| Loctite® RED | Utility Knife |
| 10MM Socket | |

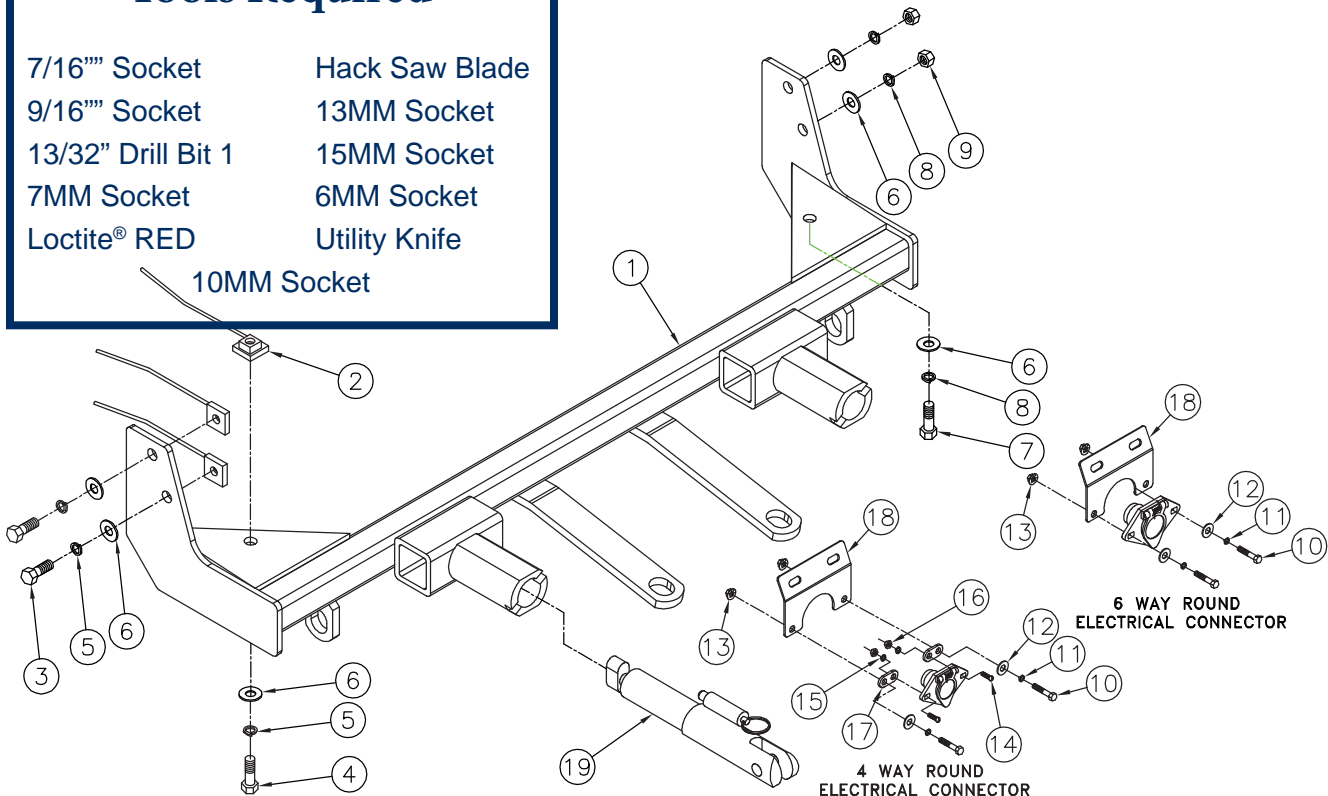

Important:

Use only genuine factory replacement parts on your baseplate. Do **NOT** substitute homemade or non-typical parts. If a bolt is lost or in need of replacement, for your safety and the preservation of your baseplate, be sure to use a replacement bolt of the same grade (In most cases it will be Grade 5, please reference the parts list above). Replacement parts may be ordered through your nearest Blue Ox® Dealer or Distributor.

BX3232

2007 Pontiac Solstice (No Turbo)

Installation Instructions

Vehicle Weight:

Motorhome mount tow bars are recommended for use with this baseplate. Due to the design of the removable tabs, the RangeFinderII, Adventurer, and Ambassador tow bars can not be used. The Acclaim tow bar may be used, but will not fold and store on the front of the vehicle. Adapters, except the BX8833 and BX88151, can not be used with this baseplate.

Installation Notes: The fascia is removed and reinstalled during installation of the baseplate. Drilling is required. Trimming of the fascia and air dam is required.

The dimensional variations between otherwise identical vehicles can be considerable. While the baseplate was designed for easy installation, it may be necessary to tailor the baseplate slightly to compensate for auto manufacturer's tolerances. These minor adjustments may include filing a hole slightly, bending electrical rods and/ or bending end plates.

The BX8869 Bulb and Socket Wiring Kit is recommended for this vehicle.



Installation Instructions:

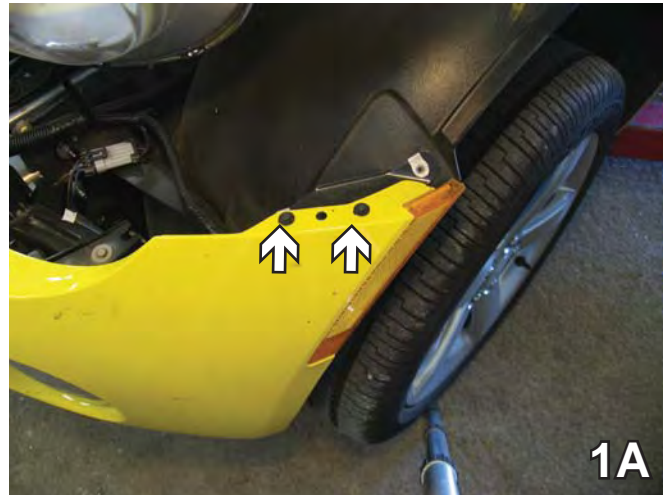

1. Using a 7MM socket remove the 9 hex bolts from the flat top edge of fascia starting with the two bolts above the tire and continuing around to the two bolts above the other tire. Set bolts aside to be reinstalled later.

BX 3232
2007 Pontiac Solstice (No Turbo)
Installation Instructions

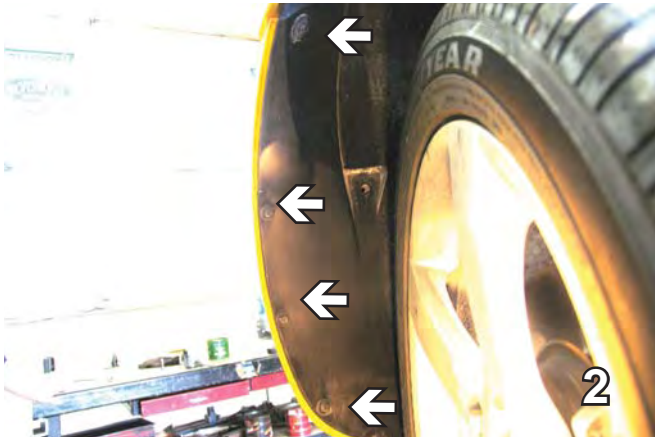

2. Using a 7MM socket, remove the 4 hex bolts just forward the front tire. Do this to both sides and set aside for later reinstallation.



3. Using a flat screwdriver, remove 3 push pins from up underneath. Set push pins aside to be reinstalled later. Do this to both sides of the vehicle.



4. There is a bolt just below headlight assembly and behind fascia to be removed with a 10MM socket. Remove bolt and set aside for later reinstallation. Unhook the marker lights.



5. Using a flat screwdriver, remove the 4 push pins from the center of the fascia. Pull fascia corners out to the side of vehicle, then pull fascia forward and carefully set aside fascia and push pins for later reinstallation.

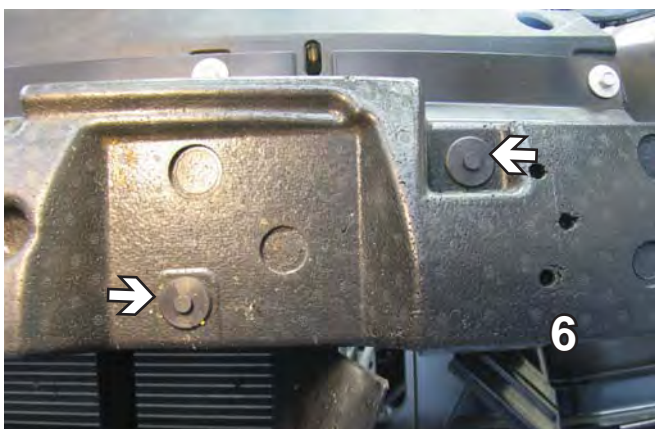

6. Removing 2 push pins using a flat screwdriver. Do this to both sides of the vehicle. Remove styrofoam from bumper. Set aside push pins and styrofoam for later reinstallation.

2007 Pontiac Solstice (No Turbo)

Installation Instructions



7. Using a 10 MM socket, remove the four bolts and the air dam from below the bumper. Set aside bolts and air dam for later reinstallation.

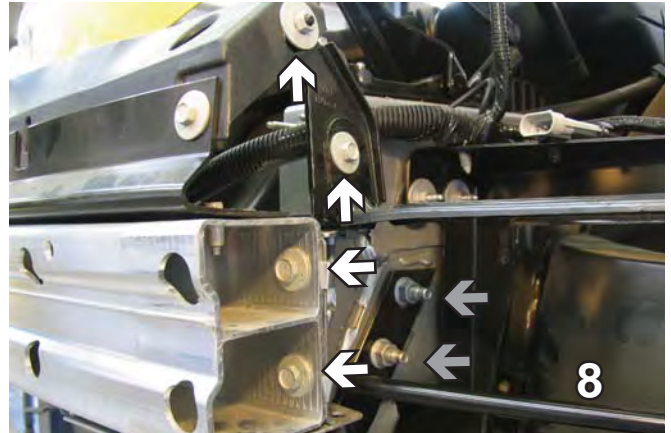

8. To remove the bumper, using a 10MM socket remove both top bolts. Then remove the bottom two bolts inside the bumper end using a 13MM socket. Using a 15MM socket, remove the back two hex nuts (grey arrows). Set aside bolts and nuts for later reinstallation.



9. Using a 13MM socket, remove two more bolts from both sides. Set bolts aside to be reinstalled later.

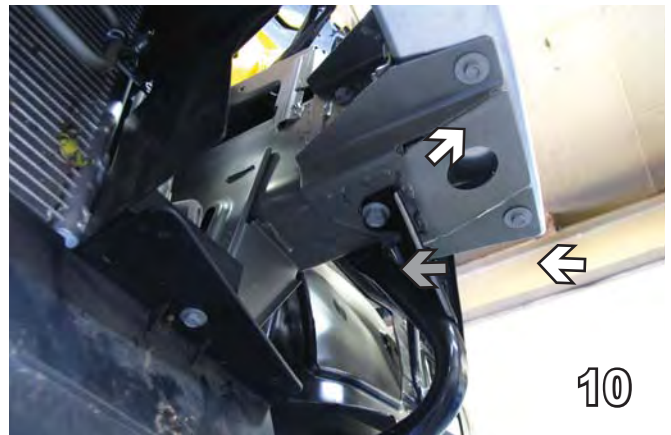

10. Remove three bolts underneath the bumper. Use a 10MM socket on the top two and a 15MM socket for the bottom one (grey arrow). Set aside bolts for later reinstallation.



11. Up on top, remove one bolt using a 10MM socket. Set aside bolt for later reinstallation.

BX3232

2007 Pontiac Solstice (No Turbo)

Installation Instructions

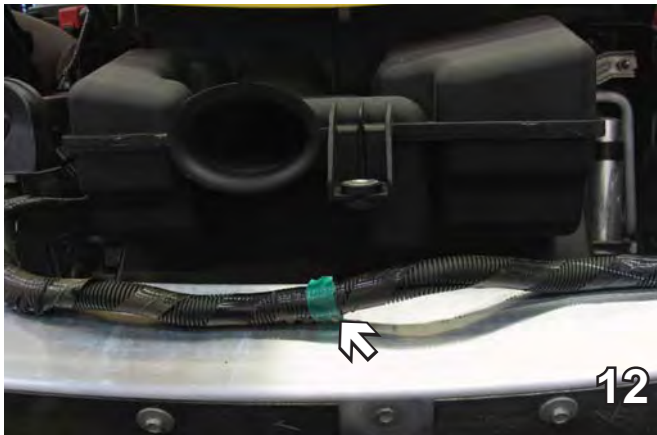

12. Remove three Christmas tree push pins before removing bumper. Set bumper and push pins aside for later installation.

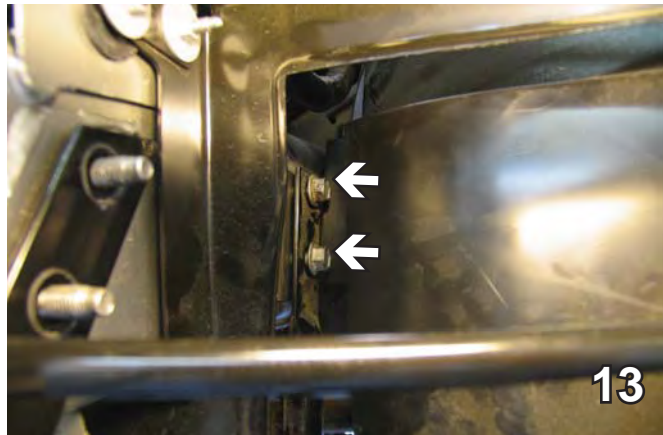

13. To remove support bar, remove 2 bolts behind fender well using a 15MM socket. This support bar will not be reinstallation.

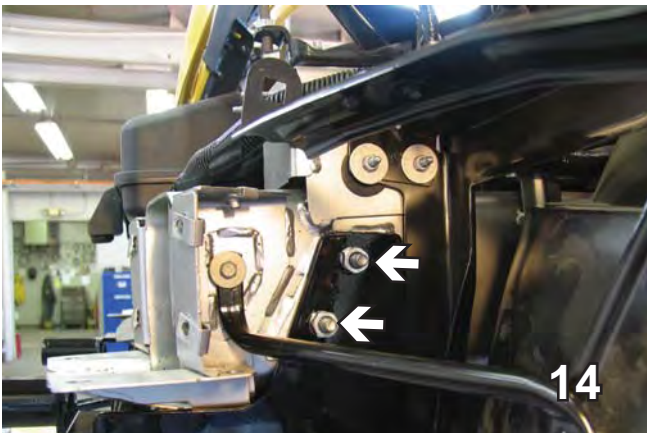

14. On the driver's side tip base plate so that hole starts on these two studs. Hand tighten the two 10M hex nuts and lock washers.

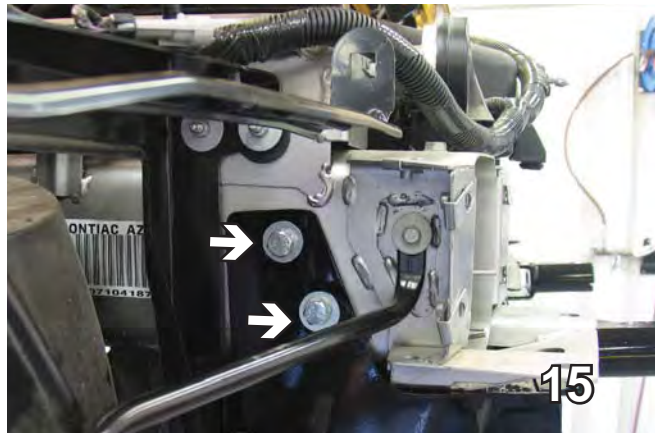

15. On the passenger side, hold the base plate level, up as far as possible and the same distance from the front as on the driver's side, mark holes and drill using a 13/32" drill bit. To attach base plate use two 3/8"-16 x 1 1/4" hex bolts with 3/8" lock and flat washers and 3/8" nut plates. Apply Loctite Red on passenger's side bolts and driver's side studs and tighten hex nuts.

BE SURE TO USE LOCTITE® RED ON ALL BOLTS BEFORE TIGHTENING. TIGHTEN ALL BOLTS ACCORDING TO THE TORQUE CHART ON THE FRONT PAGE OF THESE INSTRUCTIONS OR ON PAGE 3 OF THE BASEPLATE TOWING GENERAL INSTRUCTIONS.

BX3232

2007 Pontiac Solstice (No Turbo)

Installation Instructions



16. Make sure the base plate is straight. On the driver's side only, attach 10MM-1.5 x 35MM hex bolt with a 10MM lock washer and a 3/8" flat washer into existing threaded hole, tighten with Loctite Red.



17. On the passenger side, use a 13/32" drill bit to drill a hole.



18. Insert 3/8" nut plate into frame end to align with drilled hole and tighten 3/8"-16 x 1 1/2" hex bolt, 3/8" flat and lock washer with Loctite Red.

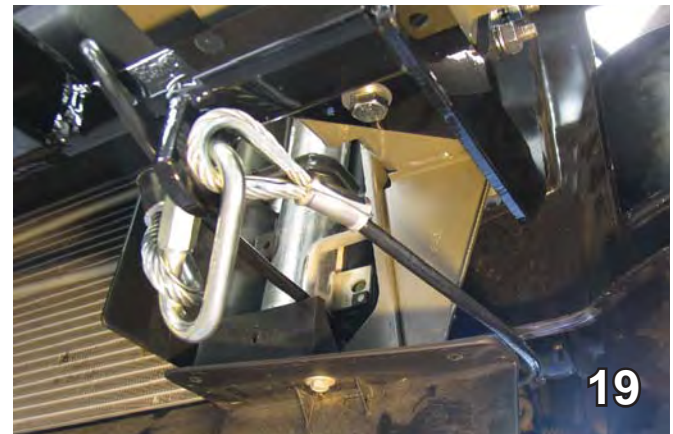

19. Attach baseplate safety cables as in above photo or as close as possible. This cable has an extra wrap around the base plate because there was plenty to work with. If you are unable to place safety cables in this position, position the cables around a solid piece of the frame. 226-0047 base plate safety cables and 229-0359 quick links are recommended.



20. Using a utility knife, cut the ends off of the plastic air dam from below the bumper.

BX3232

2007 Pontiac Solstice (No Turbo)

Installation Instructions

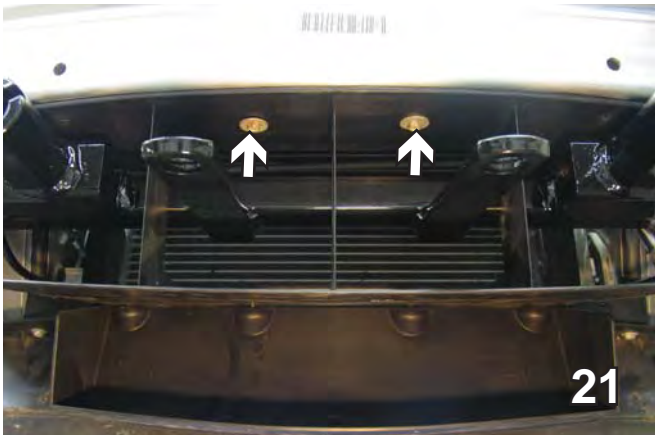

21. Reinstall bumper and air baffle over the top of the base plate. Attach with two center bolts.



22. Hold fascia as close to its original position as possible and cut a hole in the grille with a hack saw blade for attachment tab receivers to come through. Do this to both sides. Then reinstall fascia.



23. Cut a hole in the grille for the electrical plug to go through. Place electrical connector bracket on the back side of the grille and attach with 1/4"-20 x 1 1/2" hex bolts, flat and lock washers and 1/4"-20 whiz nuts.

Be sure that **ALL** electrical connections are plugged in properly and functioning **BEFORE** installing the fascia.

BX3232

2007 Pontiac Solstice (No Turbo) Installation Instructions

DEALER or INSTALLER:
Be certain the user receives the
instruction sheets for their products.

Install the tow bar and safety cables according to the instructions provided in their packages. When demonstrating this to the customer, be sure to include all the contents and packages.

Do **NOT** substitute other devices if the tow bar pins and clips are misplaced.

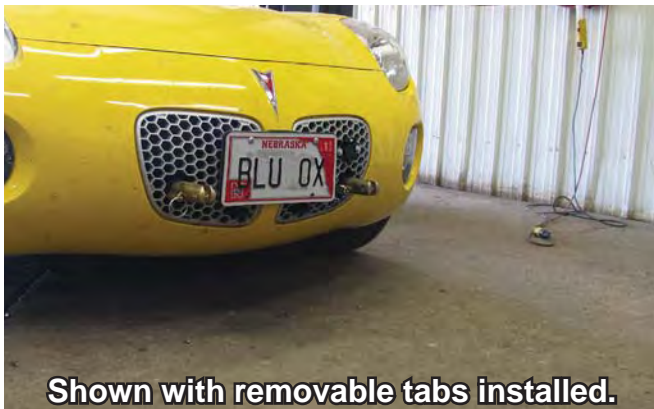

CUSTOMER SERVICE COMMITMENT

Blue Ox is committed to providing you with exceptional customer care throughout your lifetime with our products. Our team is here to assist you with any questions you may have regarding the performance of your product. Simply call 1-800-228-9289 and you can speak with our customer care team.

Additionally, please visit our website to see which rallies our Destination America team will be attending. For a nominal fee, our service technician will service your towing system to ensure it's in proper working condition. Also as a commitment to our customers, should you visit our factory you can stay at our full service Blue Ox campground at no charge along with enjoying a factory tour.

Again thank you for being our customer and for the confidence you have shown in the performance of our products. It is because of customers like you we enjoy the success we have today.



© 2007, 08, 09 Blue Ox
One Mill Road, Industrial Park
Pender, Nebraska 68047
Phone: (402) 385-3051
Fax: (402) 385-3360
www.blueox.us