

Serial Number

Please read **BOTH** these Installation Instructions and the General Towing Instructions before attempting to install or operate this equipment.

- Blue Ox® towing products and accessories are intended to be installed by Blue Ox® Dealers who are familiar with our products and have the equipment and knowledge to do “fit work.” When necessary, Blue Ox® Dealers can be found at www.blueox.us or by contacting our Customer Care Department at (888) 425-5382.
- Many Blue Ox® Baseplates are designed to use existing holes and hardware to mount the baseplate to the towed vehicle. Even though bolts are there, do not assume they are adequate for baseplate mounting. Always use hardware supplied in the hardware kit or existing hardware specified in the Baseplate Towing Installation Instructions.

Attachment Tab Height: 14”
Attachment Tab Width: 20”

Bolt Torque Specifications
Torque in Foot-Pounds for Metric Bolts

Bolt Size	Grade 8.8	Grade 10.9
6MM	6	8
8MM	16	22
10MM	31	40
12MM	54	70
14MM	89	117

Confirm the towability and pre-towing procedures for your vehicle with the owner’s manual or contact the vehicle’s manufacturer for specific towing procedures.

Bolt Torque Specifications
Torque in Foot-Pounds for Inch Bolts

Bolt Size	Grade 5	Grade 8
1/4”	10	14
5/16”	19	29
3/8”	33	47
7/16”	54	78
1/2”	78	119
5/8”	154	230



! WARNING

Failure to read and follow these instructions could result in separation of the towed vehicle from the tow bar, causing property damage, loss of towed vehicle, personal injury or death.

BX3234

2009.5 Pontiac G6

Installation Instructions

Parts List

Ref. No.	Qty.	Part #	Description
1	1	61-6652	Weldment, Base Plate, BX3234
2	3	61-5208	Weldment, 3/8" Nut Plate, with 14 Inch Wire
3	2	61-5556	Weldment, 3/8" Nut Plate, with 12 Inch Wire
4	4	201-0443	3/8-16 x 1 Hex Bolt, Grd. 5, ZP
5	5	201-0440	3/8-16 x 1 1/2 Hex Bolt, Grd. 5, ZP
6	9	203-0010	3/8" Lock Washer, ZP
7	4	202-0003	3/8-16 Hex Nut, ZP
8	1	201-0655	6MM-1 x 30MM Hex Bolt, Grd. 8.8, ZP
9	1	203-0161	6MM Lock Washer, ZP
10	1	203-0001	1/4" Flat Lock Washer, ZP
11	2	201-0553	1/4-20 X 1/2 Hex Wshd. Type F Tcs, ZP
12	2	201-0192	10-32 X 1/2 Slot, RD. HD. Screw
13	2	203-0054	#10 Lock Washer
14	2	202-0047	#10-32 Hex Nut
15	2	101-5822	Adapter, 4 Way Connector
16	2	62-3469	Attachment Tab Assembly, Rem, SF/LB, 1 Hole
	1	201-0654	#10-16 x 1, Self Drilling Screw (Not Shown)
	2	226-0046	Baseplate Safety Cable, 36" CL III (Not Shown)
	2	229-0359	Quicklink, 3/8, ZP (Not Shown)
	2	290-0437	Receiver, Cap Plug (BLK) (Not Shown)

Tools Required

7MM Socket	Flat Screw Driver
10MM Socket/Wrench	Utility Knife
9/16" Socket/Wrench	1" Hole Saw
Large Vise Grip	13/32" Drill Bit
Drill	Loctite® RED

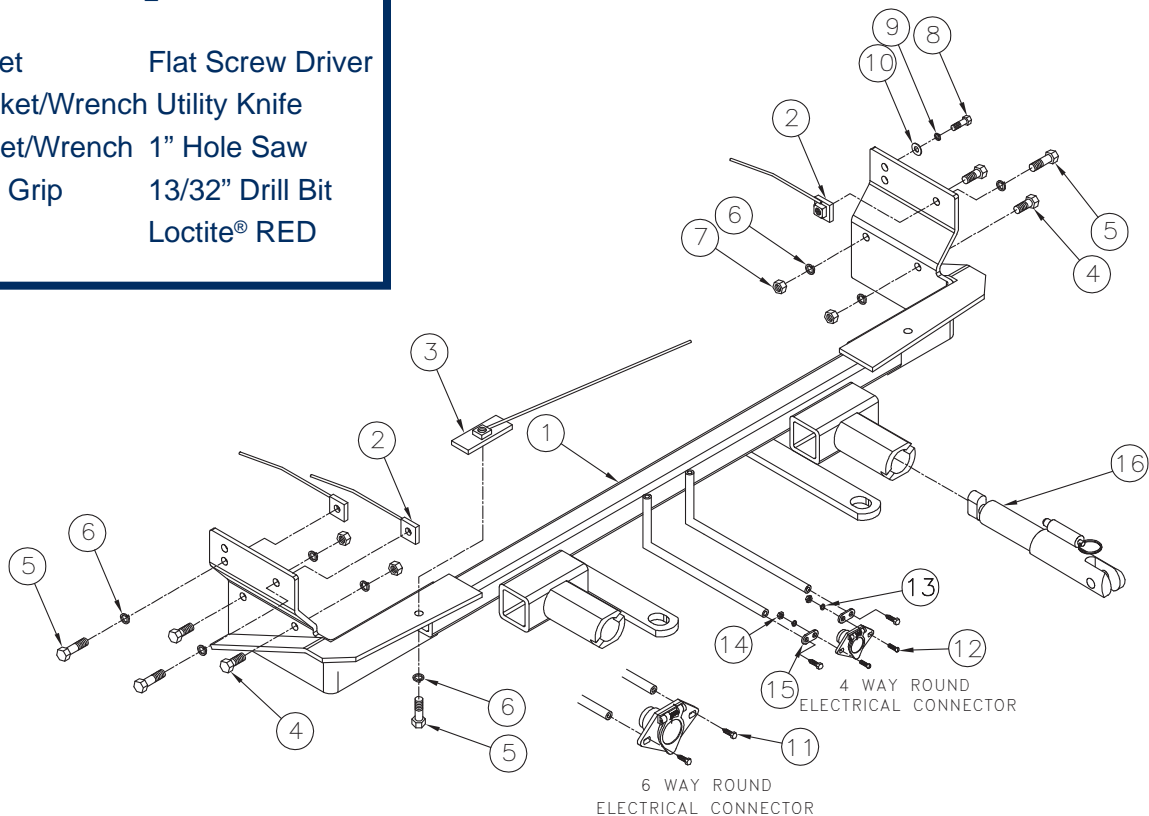

Important:

Use only genuine factory replacement parts on your baseplate. Do **NOT** substitute homemade or non-typical parts. If a bolt is lost or in need of replacement, for your safety and the preservation of your baseplate, be sure to use a replacement bolt of the same grade (In most cases it will be Grade 5, please reference the parts list above). Replacement parts may be ordered through your nearest Blue Ox® Dealer or Distributor.

BX3234

2009.5 Pontiac G6

Installation Instructions

Vehicle Weight:

Motorhome mount tow bars are recommended for use with this baseplate. Due to the design of the removable tabs, the RangeFinderII, Adventurer, and Ambassador tow bars can not be used. The Acclaim tow bar may be used, but will not fold and store on the front of the vehicle. Adapters, except the BX8833 and BX88151, can not be used with this baseplate.

Installation Notes: The front fascia, horn bracket and air baffle are removed for baseplate installation. Drilling is required. Trimming of air dam and fascia is required.

The dimensional variations between otherwise identical vehicles can be considerable. While the baseplate was designed for easy installation, it may be necessary to tailor the baseplate slightly to compensate for auto manufacturer's tolerances. These minor adjustments may include filing a hole slightly, bending electrical rods and/ or bending end plates.

The BX8869 Bulb and Socket Wiring Kit is recommended for this vehicle.



Installation Instructions:

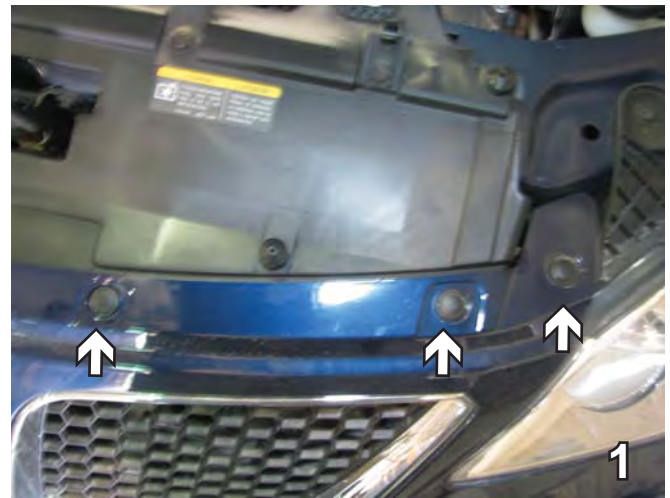

1. Remove the six push pins, three on each side, from the top edge of fascia just between headlight assemblies. Set pins aside to be reinstalled later.



2. Remove three christmas tree push pins (white arrows) from the edge of wheel well, just forward of front tire. Using a 7MM socket, remove one metric bolt (gray arrow in 2B) half way up. At the top, using a 10MM socket remove another metric bolt (gray arrow in 2A). Do this on both sides. Set pins and bolts aside to reinstall later.

BX 3234
2009.5 Pontiac G6
Installation Instructions



3. On the lower edge of the fascia, just forward of the front tire, using a 7MM socket remove one metric bolt (white arrow). Continuing around, remove two push pins (gray arrows). Using the 7MM socket, remove five metric bolts (3B). Remove two more push pins and one more metric bolt. Pull the corners of the fascia to the side of the vehicle to release the tabs. Pull fascia forward and carefully set fascia and bolts and pins aside to be reinstalled later.

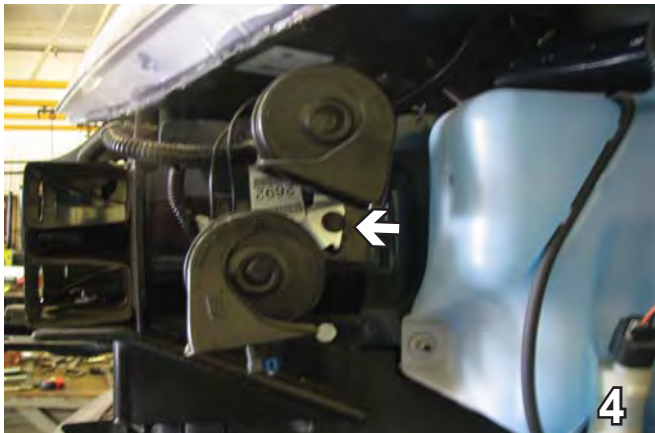

4. Using the 10MM socket, remove metric bolt from horn bracket on the driver's side and set assembly aside to be reinstalled later.



5. On the passenger side, remove the push pin from the front of the air baffle. Using a 10MM socket, remove one metric bolt from the back. Set assembly aside to be reinstalled later.

BX3234
2009.5 Pontiac G6
Installation Instructions

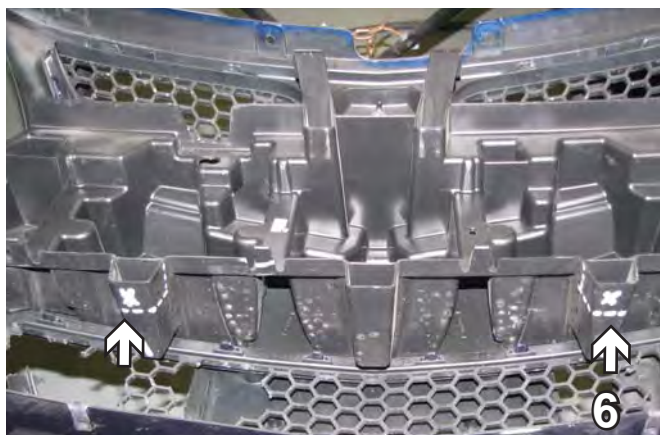

6. On the back side of the fascia, using the utility knife, cut the two outside tabs down 1 1/4".

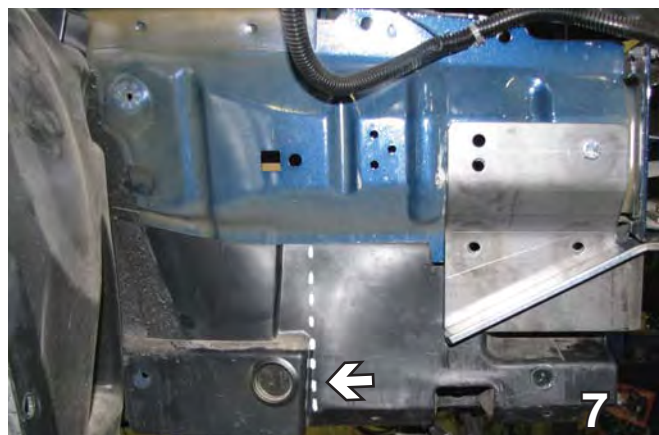

7. On the passenger side, using a utility knife, cut the plastic straight up next to the extended tab, as shown, and remove for nut plate insertion.



8. On the driver's side, using a utility knife, cut the plastic straight down even with the edge of the washer reservoir and remove.

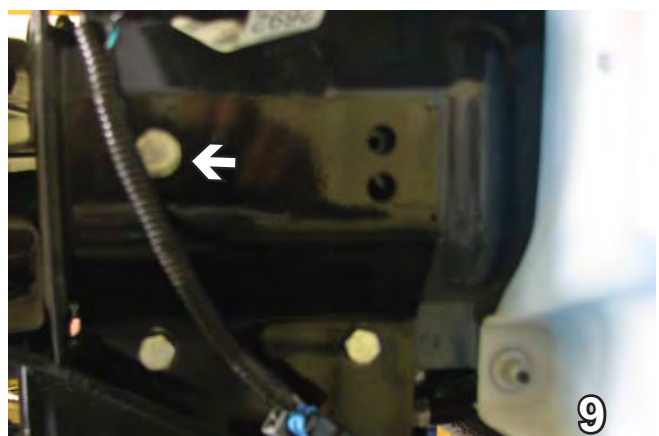

9. Slide baseplate onto the frame rail and up to bottom of metal bumper, clamp baseplate to bumper with vise grip, both sides. Align baseplate to existing bolt location for the horn bracket on the driver's side, replace and tighten existing metric bolt for horn bracket to hold baseplate in place. Be sure to align lower holes of baseplate to the center of lower frame webbing before drilling holes. Align

BE SURE TO USE LOCTITE® RED ON ALL BOLTS BEFORE TIGHTENING. TIGHTEN ALL BOLTS ACCORDING TO THE TORQUE CHART ON THE FRONT PAGE OF THESE INSTRUCTIONS OR ON PAGE 3 OF THE BASEPLATE TOWING GENERAL INSTRUCTIONS.

passenger's side of baseplate to the frame to the same location as the driver's side and clamp to the bottom edge of metal bumper as shown in photo for driver's side. Using the baseplate as a template, drill the two lower holes and the top front hole with the 13/32" drill bit. Insert the 3/8-16 x 1" hex bolts into the two lower drilled holes of baseplate, tighten the 3/8-16 hex nut and lock washer with the 9/16" socket. Insert the nut plate into the opening in the bottom of frame to align with upper front drilled hole, tighten the 3/8-16 x 1 1/2" hex bolt and 3/8" lock washer into upper front drilled hole. Be sure and use loctite red on all bolts before tightening. Tighten all bolts according to torque chart in the General Instruction sheet.

BX3234
2009.5 Pontiac G6
Installation Instructions

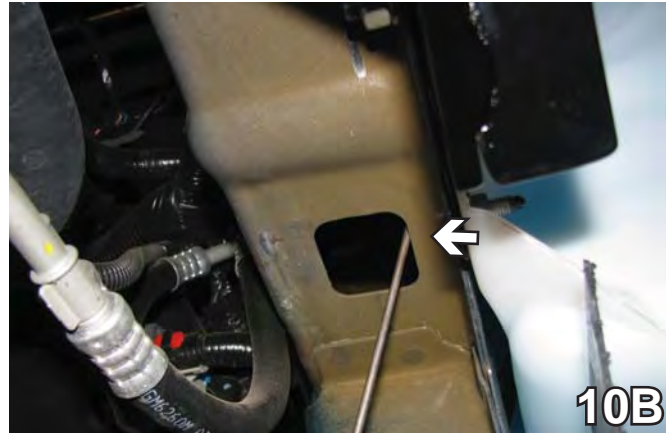

10. Using the baseplate as a template, drill a hole into the bottom of metal bumper with the 13/32" drill bit, both sides. Insert the 3/8" nut plate with the 12" wire into the open end of metal bumper to align with drilled hole, tighten 3/8-16 x 1 1/2" hex bolt and 3/8" lock washer with the 9/16" socket, both sides. Be sure and use loctite red on all bolts before tightening. Tighten all bolts according to torque chart in the General Instruction sheet.



11. Remove rubber grommet from the front bolt location on the air baffle. Reinstall the air baffle on the passenger's side to its original position, using the existing metric bolt and lower push pin. Slide front bolt location over the top of front bolt of baseplate. Using the 5/16" nut driver and drill, install the #10 x 1 self drilling screw through air baffle webbing and into frame. This will help to stabilize the air baffle. Do not drill into baseplate.

12. Remove horn bracket's existing metric bolt on the driver's side from baseplate (installed in step 9). Reinstall horn bracket using the 6MM-1 x 30MM, 6MM lock washer and 1/4" flat washer.



BX3234
2009.5 Pontiac G6
Installation Instructions



13. Attach permanent baseplate safety cables to the convenience link on the baseplate. Wrap the cables around the vehicle frame. Additional options may interfere with suggested mounting, in this case secure the cables to a solid piece of the frame as described in instructions included with the permanent baseplate safety cables. Be sure the safety cables do not rub against any hoses or moving parts. Do this to both sides of the vehicle.

Be sure that **ALL** electrical connections are plugged in properly and functioning **BEFORE** installing the fascia.

14. Reinstall the fascia. Be sure to install all bolts and push pins.
15. The dimensional variations between otherwise identical cars can be considerable. While the baseplate was designed for easy installation, it may be necessary to tailor the baseplate slightly to compensate for auto manufacturers' tolerances. These minor adjustments may include filing a hole slightly, bending electrical rods, adding shims and/ or bending endplates.
16. Install the tow bar and safety cables according to the instructions included in their packages.
17. Do not substitute other devices if the tow bar pin and clip are lost.
18. DEALER OR INSTALLER: BE CERTAIN THE USER RECEIVES THE INSTRUCTION SHEET.

BX3234

2009.5 Pontiac G6

Installation Instructions

DEALER or INSTALLER:
Be certain the user receives the instruction sheets for their products.

Install the tow bar and safety cables according to the instructions provided in their packages. When demonstrating this to the customer, be sure to include all the contents and packages.

Do **NOT** substitute other devices if the tow bar pins and clips are misplaced.



If the baseplate is in an accident, it must be replaced. **DO NOT** use it again! An accident can cause unseen damage and using it again could result in more damage or serious injury. **DO NOT** use the baseplate if it is damaged or missing parts.

CUSTOMER SERVICE COMMITMENT

Blue Ox is committed to providing you with exceptional customer care throughout your lifetime with our products. Our team is here to assist you with any questions you may have regarding the performance of your product. Simply call 1-800-228-9289 and you can speak with our customer care team.

Additionally, please visit our website to see which rallies our Destination America team will be attending. For a nominal fee, our service technician will service your towing system to ensure it's in proper working condition. Also as a commitment to our customers, should you visit our factory you can stay at our full service Blue Ox campground at no charge along with enjoying a factory tour.

Again thank you for being our customer and for the confidence you have shown in the performance of our products. It is because of customers like you we enjoy the success we have today.



© 2007, 08, 09 Blue Ox
One Mill Road, Industrial Park
Pender, Nebraska 68047
Phone: (402) 385-3051
Fax: (402) 385-3360
www.blueox.us