



Baseplate Installation Instructions

BX3235 2009 Pontiac G6 GT

Installation Instructions

Serial Number

Please read BOTH these Installation Instructions and the General Instructions before attempting to install or operate this equipment.

- Blue Ox® towing products and accessories are intended to be installed by Blue Ox® Dealers who are familiar with our products and have the equipment necessary and knowledge to do "fit work". When necessary Blue Ox® Dealers can be found at www.blueox.com or by contacting our Customer Care Department at (402) 385-3051 or toll free (888) 425-5382.
- Many Blue Ox® Baseplates are designed to use existing holes and hardware to mount the baseplate to the towed vehicle. Even though bolts are there, do not assume they are adequate for baseplate mounting. Always use hardware supplied in the hardware kit and existing hardware specified in the Baseplate Installation Instructions.

Attachment Tab Height: 15"

Attachment Tab Width: 27"

Bolt Torque Specifications

Torque in Foot-Pounds for Metric Bolts

Bolt Size	Grade 8.8	Grade 10.9
6MM	6	8
8MM	16	22
10MM	31	40
12MM	54	70
14MM	89	117

Confirm the towability and pre-towing procedures for your vehicle with the owner's manual or contact the vehicle's manufacturer for specific towing procedures.

Bolt Torque Specifications

Torque in Foot-Pounds for Inch Bolts

Bolt Size	Grade 5	Grade 8
1/4"	10	14
5/16"	19	29
3/8"	33	47
7/16"	54	78
1/2"	78	119
5/8"	154	230

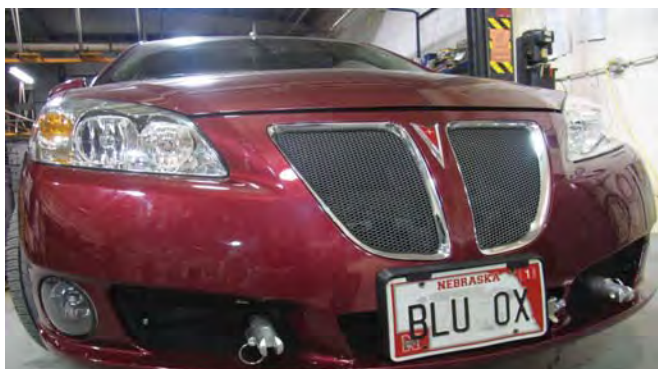

If the front of your vehicle looks different than this, call us at (888) 425-5382.

! WARNING

Failure to read and follow these instructions could result in separation of the towed vehicle from the tow bar, causing property damage, loss of towed vehicle, personal injury or death.

BX3235

2009 Pontiac G6 GT

Installation Instructions

Parts List

Ref. No.	Qty.	Part #	Description
1	1	61-6688	WLDM'T, BP, BX3235
2	2	61-5208	WLDT, NUT PLT, 1/4X1X1, 3/8 BLT WIR
3	4	201-0443	3/8-16 X 1 HEX BOLT GRD.5, ZP
4	2	201-0440	3/8-16 X 1 1/2 HEX BOLT, GRD.5, ZP
5	6	203-0010	3/8 LOCK WASHER, ZPP
6	4	202-0090	3/8-16 HEX NYL. INS. LOCK NUT, ZP
7	2	201-0553	1/4-20 X 1/2 HX.WSHD.TYPE F TCS, ZP
8	2	201-0192	10-32 X 1/2 SLOT, RD. HD. SCREW
9	2	203-0054	#10 LOCK WASHER
10	2	202-0047	#10-32 HEX NUT
11	2	101-5822	ADAPTER, 4 WAY CONNECTOR
12	2	62-3469	ATT TAB ASSY, REM, SF/LB, 1 HOLE BOLTS
E	2	226-0046	BASEPLATE SAFETY CABLE, 36" CL III
	2	229-0359	QUICKLINK, 3/8, ZP
	2	290-0437	RECEIVER, CAP PLUG (BLK)

Tools Required

- 7MM Socket
- 10MM Socket
- 9/16" Socket
- 13/32" Drill Bit
- Large Vise Grip
- Flat Screwdriver
- Utility Knife
- Loctite® RED

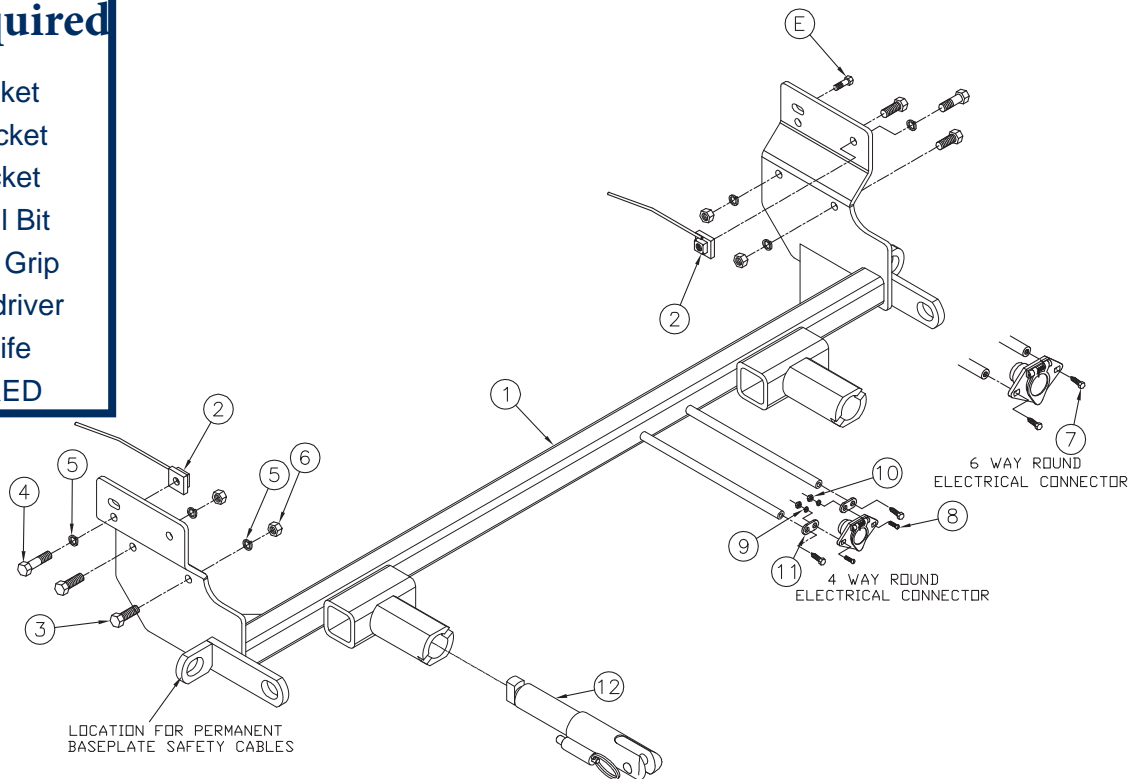

Important:

Use only genuine factory replacement parts on your baseplate. Do NOT substitute homemade or non-typical parts. If a bolt is lost or in need of replacement, for your safety and the preservation of your baseplate, be sure to use a replacement bolt of the same grade (In most cases it will be Grade 5, please reference the parts list above). Replacement parts may be ordered through your nearest Blue Ox® Dealer or Distributor, or call our Customer Care Team at (402)385-3051. Failing to follow and/or altering these installation instructions in either installation or required equipment will void the manufacturer's warranty.

BX3235

2009 Pontiac G6 GT

Installation Instructions

Attachment Tabs:

Due to the design of the removable tabs, the RangeFinderII, Adventurer, and Ambassador tow bars can not be used. Adapters, except the BX8833 and BX88151, can not be used with this baseplate.

Instructions:

The front fascia and air baffle are removed for the baseplate installation. Drilling is required. Trimming of the air dam and the fascia is required.

The dimensional variations between otherwise identical vehicles can be considerable. While the baseplate was designed for easy installation, it may be necessary to tailor the baseplate slightly to compensate for auto manufacturer's tolerances. These minor adjustments may include filing a hole slightly, bending electrical rods or bending end plates.

The BX8869 Bulb and Socket Wiring Kit is recommended for this vehicle.



Installation Instructions:

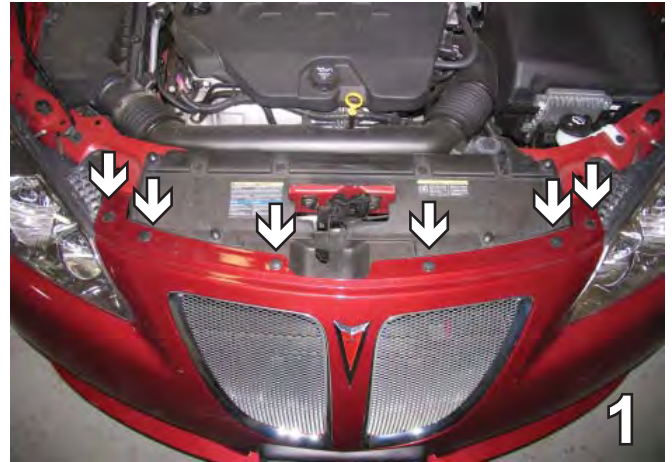

1. Using the flat screwdriver, remove the six pushpins from the top of the fascia. Set pushpins aside to reinstall later.



2. Using a 10MM socket, remove the bolt just forward of the front tire on the edge of the wheel well cover. Do this to both sides of the vehicle. Set bolts aside to reinstall later.

BX3235

2009 Pontiac G6 GT

Installation Instructions



3. Just forward of the front tire, on the edge of the wheel well cover, using a 7MM socket remove the bolt (gray arrow). Using a flat screwdriver, remove the two push pins (white arrows). Do this to both sides of the vehicle. Set bolts and pushpins aside to reinstall later.

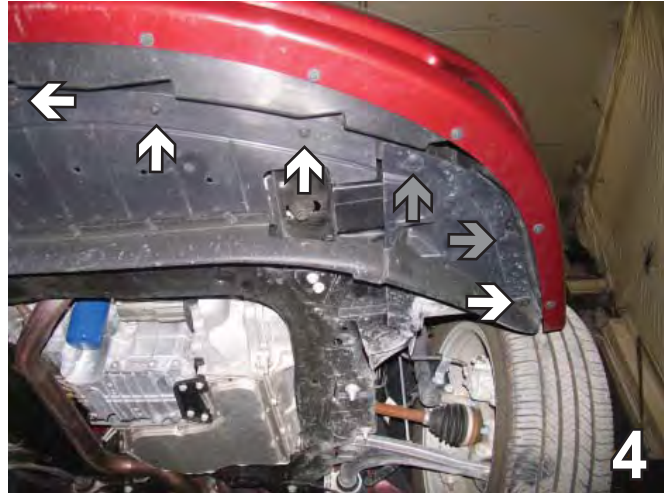

4. Using the 7MM socket, remove seven metric bolts from underneath corner of the front fascia, forward of the front tire, as indicated by the white arrows in the photo above. Remove two pushpins, as indicated by the grey arrow in the photo above. Do this around the vehicle. Remove fascia by pulling it out to the side and forward a little bit. Set fascia, bolts and pushpins aside carefully to reinstall later.

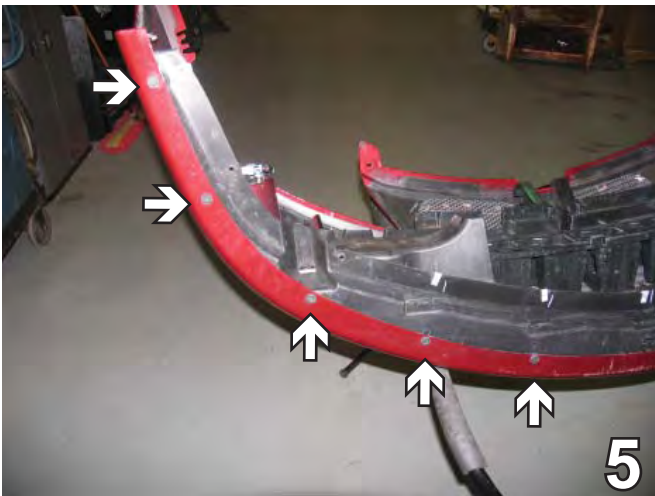

5. Using the flat screwdriver, remove the ten push pins on the bottom side of the fascia attached to the lower air dam. Set air dam and push pins aside to reinstall later.

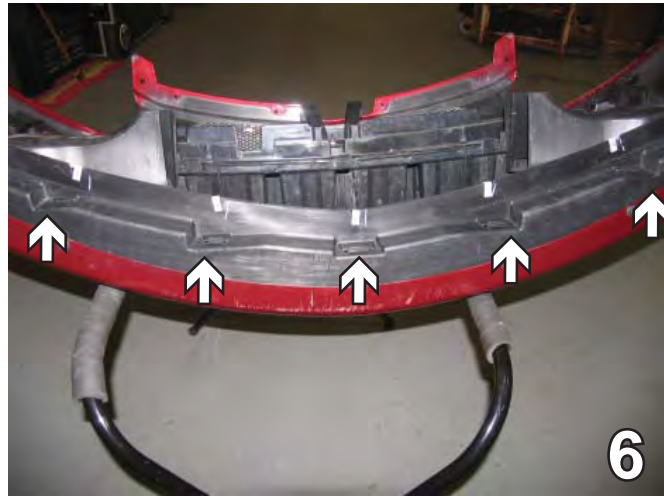

6. Unclip the five clips and remove the plastic cover. Set plastic cover aside to reinstall later.

7. Using the 10MM socket, remove metric bolt from horn bracket on the driver's side and set assembly aside.



BX3235

2009 Pontiac G6 GT

Installation Instructions

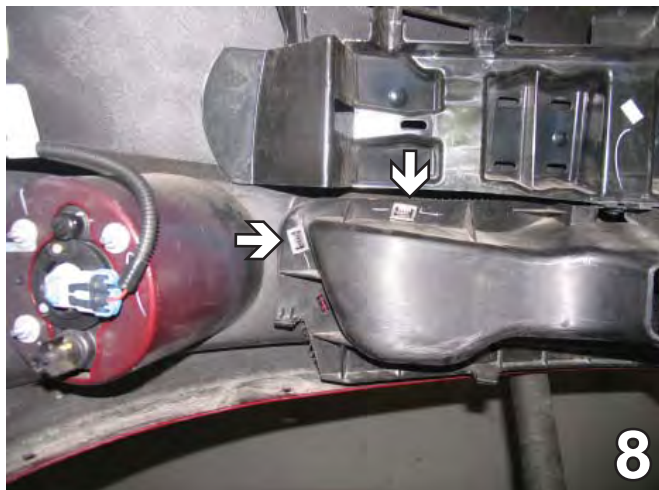

8. Optional step, see step 10: Pry off the two metal clips on each side holding the air dam. Do this on both sides.



9. Using a flat screwdriver, remove the two push pins inside the air dam, one on each side. Remove the plastic air dam. Set air dam and push pins aside to reinstall later.



10. Optional step: Remove the four clips holding the grill section and remove the grill piece. Or if you want to save the grill piece, leave it in and put the clips, removed in step 8 back in. The air dam removed in step 8 may also be reinstalled. It will need to be trimmed in order for the baseplate to fit around it.

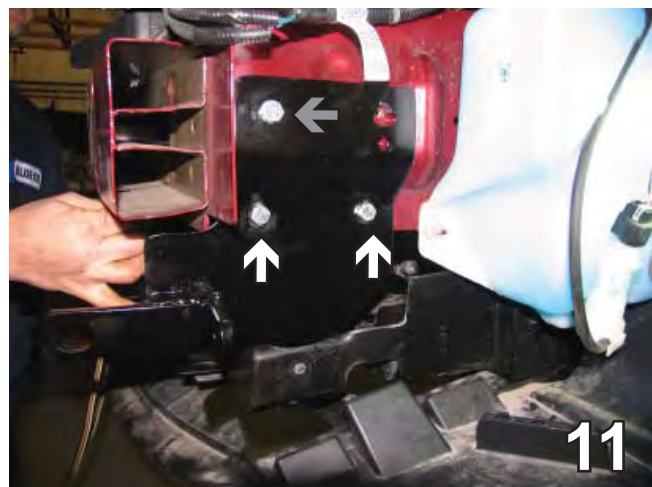

11. Slide the baseplate up on the driver's side, align with the existing hole. Be sure the baseplate is level with respect to the vehicle frame and clamp in place with vise grips. Using the baseplate as a template, drill the remaining three holes into the frame rail on the driver's side with the 13/32" drill bit. Insert two 3/8-16 x 1" hex bolts, 3/8 lock washers and 3/8-16 hex nuts into the bottom two holes. Use Loctite Red on all the bolts. Guide a 3/8-16 nut plate up through the opening in the bottom of the frame rail and align it with the 3/8-16 x 1 1/2" hex bolt and the 3/8" lock washer inserted into the upper front bolt hole (gray arrow). Do the same on the passenger side. Be sure the bottom bolts line up in the center of the webbing. Tighten and torque all bolts to specs.

BE SURE TO USE LOCTITE® RED ON ALL BOLTS BEFORE TIGHTENING. TIGHTEN ALL BOLTS ACCORDING TO THE TORQUE CHART ON THE FRONT PAGE OF THESE INSTRUCTIONS OR ON PAGE 3 OF THE BASEPLATE TOWING GENERAL INSTRUCTIONS.

BX3235
2009 Pontiac G6 GT
Installation Instructions



12. Mark the side of the air dam straight down 3 inches where the hole is and around the contour of the air dam mold around the outside edge. Remove the plastic piece. Do this on both sides.

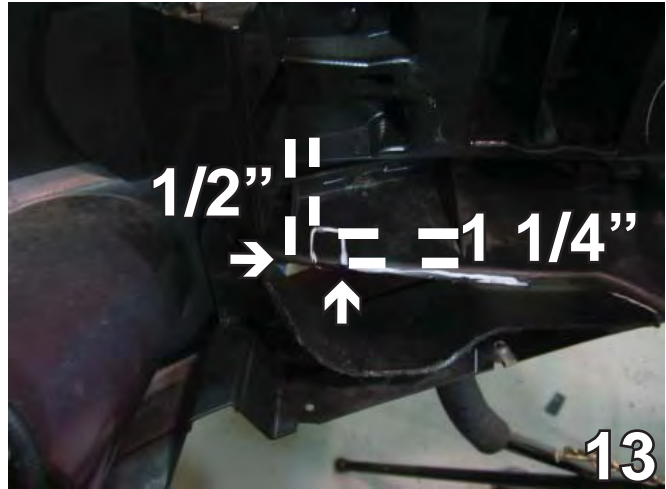

13. Using the utility knife, cut back 1 1/4" from the rib and 1/2" out from the left rib.



14. Use the existing bolt to reinstall the air baffle and reassemble the push pins.



15. Reinstall the horn on the driver's side with a 6MM x 30MM bolt and 5/16" flat washer.

BX3235

2009 Pontiac G6 GT

Installation Instructions

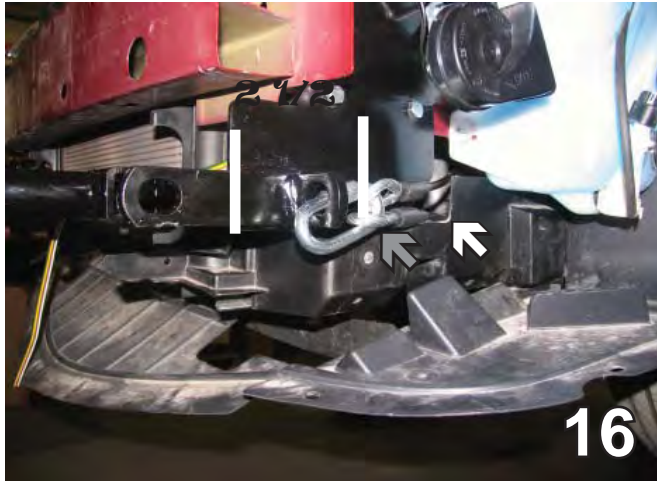

16. Attach the permanent baseplate safety cables to the provided convenience link on the baseplate (see grey arrow). The photo above shows the recommended installation of the cables to frame of vehicle (see white arrow). Additional options may interfere with suggested mounting; in this case secure the cables to a solid piece of the frame as described in the instructions included with the permanent baseplate safety cables. Be sure the safety cables do not rub against any hoses or moving parts. Do this to both sides of the vehicle.

Be sure that ALL electrical connections are plugged in properly and functioning BEFORE installing the fascia.



17. Reattach the mesh grille. Hold as close to the original location as possible and mark areas to be trimmed for convenient links, removable tabs and electrical connector. Do this on both sides of the vehicle. Some models may need more trimming, check the fascia fit.
18. Reinstall fascia inserting all bolts and pushpins. Installation of the baseplate is now complete.

Install the tow bar and safety cables according to the instructions when demonstrating this to the customer. Be sure to included all the contents and packages.

Do **NOT** substitute other devices of the tow bar pins and clips are misplaced.

BX3235
2009 Pontiac G6 GT
Installation Instructions

DEALER OR INSTALLER:

Be certain the user receives the instruction sheets for their products.

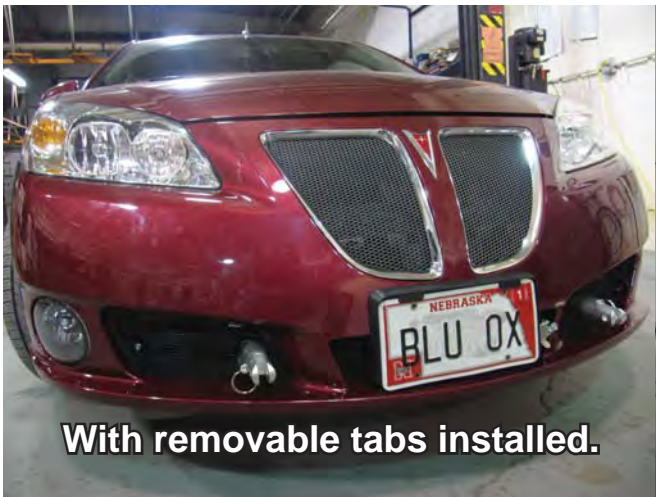

With removable tabs installed.

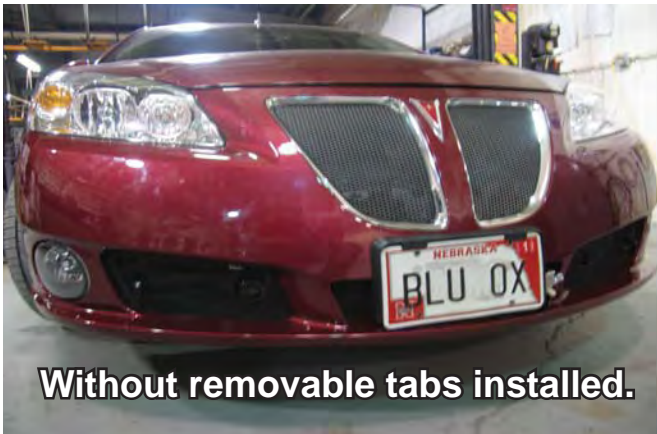

Without removable tabs installed.

If the baseplate is in an accident, it must be replaced. DO NOT use it again! An accident can cause unseen damage and using it again could result in more damage or serious injury. DO NOT use the baseplate if it is damaged or missing parts.

CUSTOMER SERVICE COMMITMENT

Blue Ox is committed to providing you with exceptional customer care throughout your lifetime with our products. Our team is here to assist you with any questions you may have regarding the performance of your product. Simply call 1-800-228-9289 and you can speak with our customer care team.

Additionally, please visit our website to see which rallies our Destination America team will be attending. For a nominal fee, our service technician will service your towing system to ensure it's in proper working condition. Also as a commitment to our customers, should you visit our factory you can stay at our full service Blue Ox campground at no charge along with enjoying a factory tour.

Again thank you for being our customer and for the confidence you have shown in the performance of our products. It is because of customers like you we enjoy the success we have today.



© 2009 Blue Ox
One Mill Road, Industrial Park
Pender, Nebraska 68047
Phone: (402) 385-3051
Toll Free: (888) 425-5382
Fax: (402) 385-3360
www.blueox.com