

BLUE OX®

Baseplates

BX3519

2005 Suzuki Aerio

Installation Instructions

Serial Number

Please read BOTH these Installation Instructions and the General Instructions before attempting to install or operate this equipment.

- Blue Ox® towing products and accessories are intended to be installed by Blue Ox® Dealers who are familiar with our products and have the equipment necessary and knowledge to do “fit work”. When necessary Blue Ox® Dealers can be found at www.blueox.com or by contacting our Customer Care Department at (402) 385-3051.
- Many Blue Ox® Baseplates are designed to use existing holes and hardware to mount the baseplate to the towed vehicle. Even though bolts are there, do not assume they are adequate for baseplate mounting. Always use hardware supplied in the hardware kit and existing hardware specified in the Baseplate Installation Instructions.

Attachment Tab Height: 15”
Attachment Tab Width: 20”

Bolt Torque Specifications
Torque in Foot-Pounds for Metric Bolts

Bolt Size	Grade 8.8	Grade 10.9
6MM	6	8
8MM	16	22
10MM	31	40
12MM	54	70
14MM	89	117

Confirm the towability and pre-towing procedures for your vehicle with the owner’s manual or contact the vehicle’s manufacturer for specific towing procedures.

Bolt Torque Specifications
Torque in Foot-Pounds for Inch Bolts

Bolt Size	Grade 5	Grade 8
1/4”	10	14
5/16”	19	29
3/8”	33	47
7/16”	54	78
1/2”	78	119
5/8”	154	230



If the front of your vehicle looks different than this, call us at (402) 385-3051.

! WARNING

Failure to read and follow these instructions could result in separation of the towed vehicle from the tow bar, causing property damage, loss of towed vehicle, personal injury or death.

BX3519

2005 Suzuki Aerio

Installation Instructions

Parts List

Ref. No.	Qty.	Part #	Description
1	1	61-6150	Weldment, Baseplate, BX3519
2	2	61-5208	3/8-16 Nut Plate, w/ 14" Wire
3	2	61-5843	Weldment, 3/8-16 Double Not Plate, B3517
4	4	102-6341	Spacer Plate, BX3517
5	6	201-0440	3/8-16 x 1 1/2" Bolt, Grd 5, ZP
6	6	203-0010	3/8" Lock Washer, ZP
7	2	201-0702	6MM-1 x 45MM Hex Bolt, Grd. 8.8
8	4	203-0001	1/4" Flat Washer, ZP
9	1	106-0101	Pipe, 3/8", Sch 40 x 1"
10	1	106-0368	Pipe, 3/8", Sch 40 x 1/2"

Tools Required

10MM Socket	Phillips Screw Driver
12MM Socket	Diagonal Cutters
Utility Knife	9/16" Socket
13/32" Drill Bit	Reciprocating Saw
Loctite® RED	Vice Grips

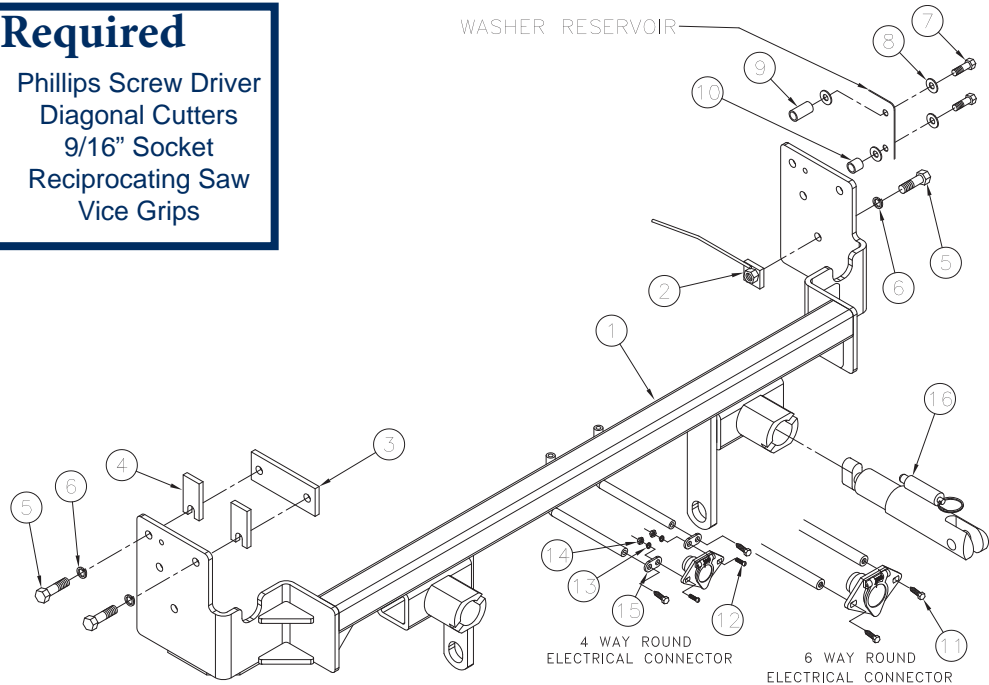

IMPORTANT:

Use only genuine factory replacement parts on your base plate. Do **NOT** substitute homemade or non-typical parts. If a bolt is lost or in need of replacement, for your safety and the preservation of your base plate, be sure to use a replacement bolt of the same grade. In most cases, it will be Grade 5—please reference the parts list. Replacement parts may be ordered through your nearest Blue Ox® dealer or distributor, or call our Customer Care Team at (402)385-3051. Failing to follow and/or altering these installation instructions in either installation or required equipment will void the manufacturer's warranty. Towing behind a non-motorized vehicle will void the warranty.

BX3519 2005 Suzuki Aerio Installation Instructions

Attachment Tabs:

Motorhome mount tow bars are recommended for use with this baseplate. Due to the design of the removable tabs, the RangeFinder II and Ambassador tow bars can not be used. Adapters, except the BX8833 and BX88151, can not be used with this baseplate.

Instructions:

The front fascia, air intake tube and windshield washer reservoir are removed for baseplate installation. Drilling is required. Trimming of the air dam behind the bumper on passenger's side is required.

The dimensional variations between otherwise identical vehicles can be considerable. While the baseplate was designed for easy installation, it may be necessary to tailor the baseplate slightly to compensate for auto manufacturer's tolerances. These minor adjustments may include filing a hole slightly, bending electrical rods or bending end plates.

The Bx8869 Bulb and Socket Wiring Kit is recommended for this vehicle.

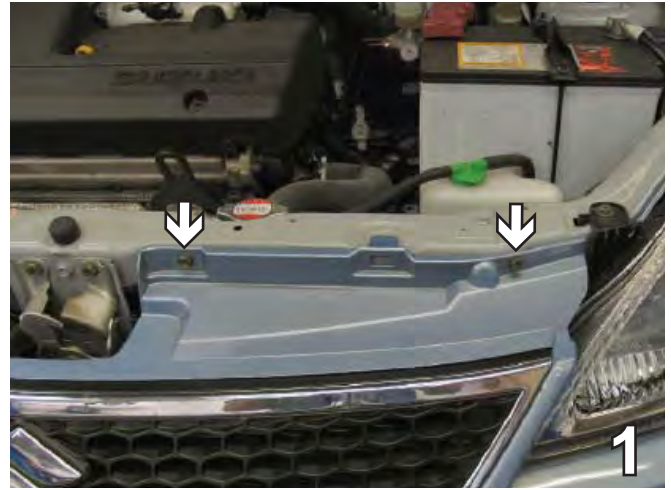

1. Using a 10MM socket remove two metric bolts from the top side of the fascia. Do this to both sides of the vehicle, the driver's side is shown. Set these bolts aside to be reinstalled later.



2. Remove one push pin from the edge of the fascia just forward of the front tire. Do this to both sides, the driver's side is shown. Set push pins aside to be reinstalled later.

Handling of some cosmetic parts when installing this product may require the use of protective covers, rags, specialty tools, etc. to prevent damage.

BX3519

2005 Suzuki Aerio

Installation Instructions



3. Using a Phillips screwdriver, remove Phillips screw from fascia corner just above front tire in wheel well. Do this to both sides of the vehicle, the driver's side is shown. Set these screws aside to be reinstalled later.



4. Forward of the front tires, on bottom edge of fascia, are two Phillips screws to remove with a Phillips screw driver. Do this to both sides of the vehicle, the driver's side is shown. Set screws aside to be reinstalled later.



5. Using a 7MM socket, remove four metric bolts just forward of the front tire on the bottom side of fascia. Set bolts aside to be reinstalled later.



6. Using the Phillips screw driver, remove the two Phillips screws below the fascia (the passenger's side is shown).

BX3519

2005 Suzuki Aerio

Installation Instructions

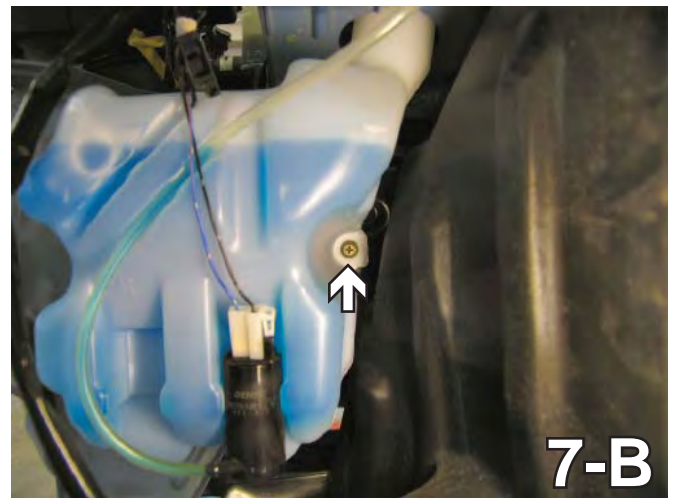
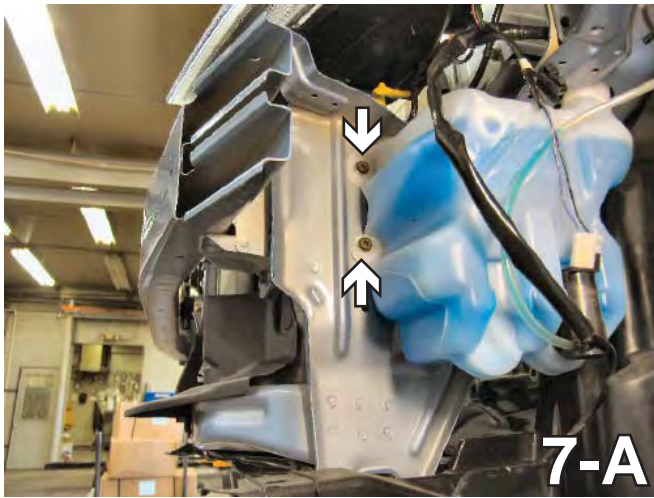

7. Remove three metric bolts from washer reservoir using a 10MM Socket, unplug electrical connections, disconnect and plug water lines. Set this aside to be reinstalled later.

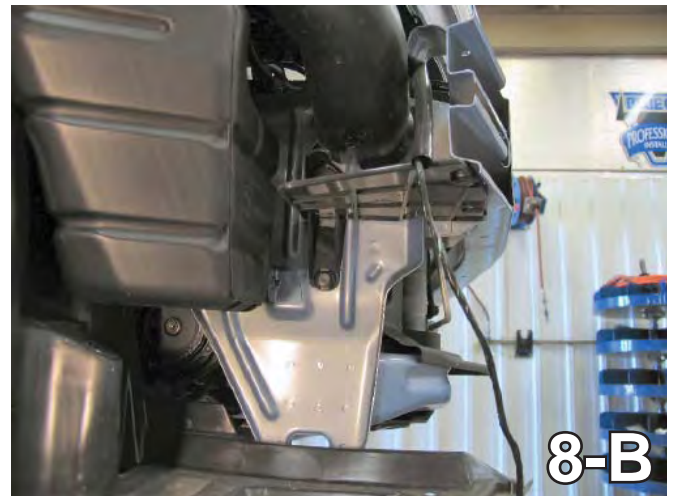
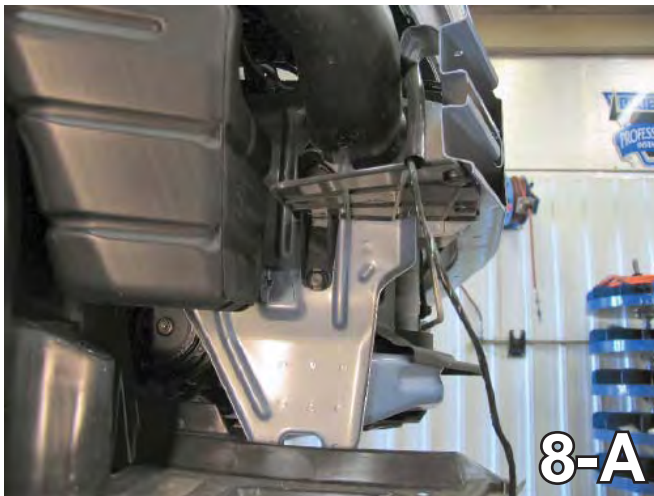

8. Remove the push pin from air intake tube on the passenger's side (8-A). Remove the two push pins from the air dam on the bottom of the metal bumper on passenger's side and one push pin on the side of the frame rail (8-B). Set push pins and air dam aside to be reinstalled later.

BX3519

2005 Suzuki Aerio

Installation Instructions

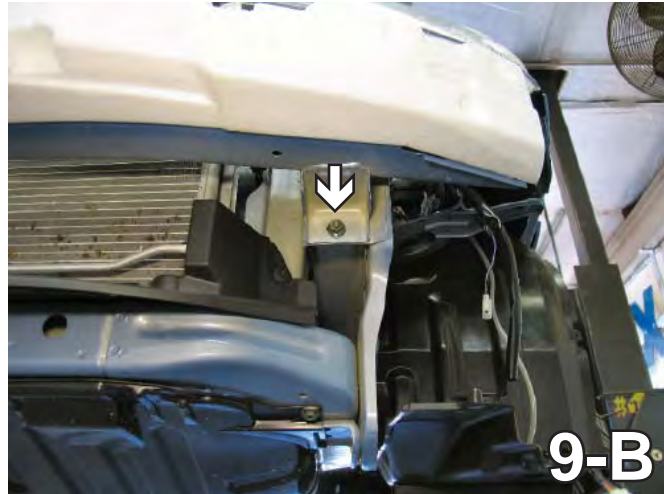
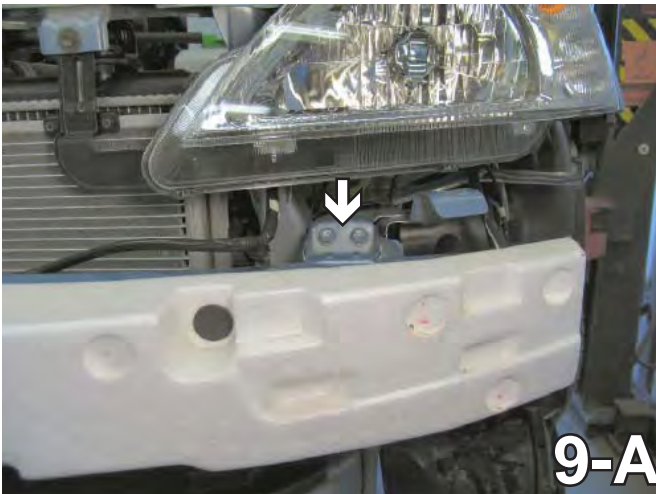

9. Using a 12MM socket remove two metric bolts from the bumper bracket between headlight assembly and the top of the metal bumper. Do this to both sides of the vehicle (9-A shows driver's sides bumper bracket). Remove the metric bolt from the bottom bumper bracket with 12MM socket. Do this to both sides of the vehicle, lift metal bumper up to release bracket tabs. Pull bumper forward and set aside (9-B).

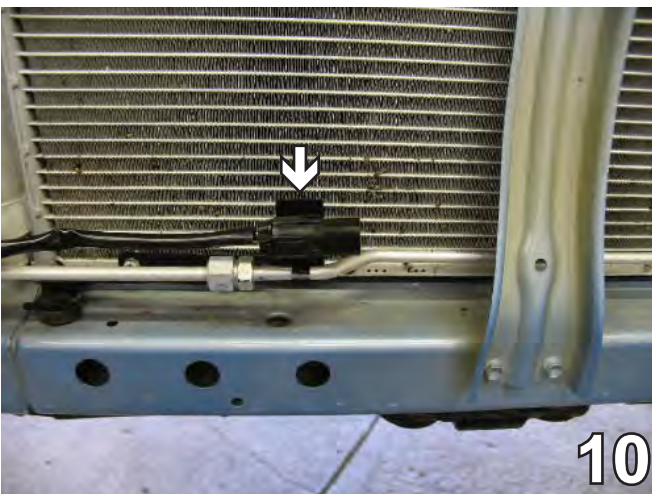

10. Press the tabs together behind temperature sensor bracket to release sensor and set sensor up out of the way to be reinstalled later.

When using power drills be aware of the dangers of torque and drill bit length.

BX3519

2005 Suzuki Aerio

Installation Instructions



11. Behind the bracket for sensor toward radiator as shown in 11-A. This will allow the condenser tube to be moved closer to radiator and prepare the area for baseplate installation. Reinstall the temperature sensor.

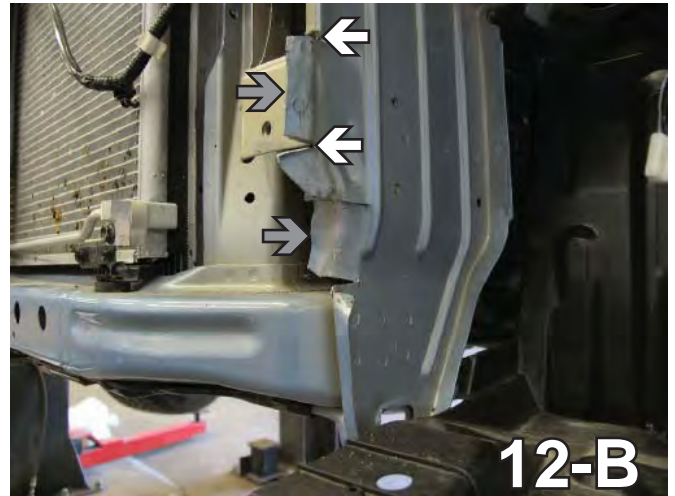
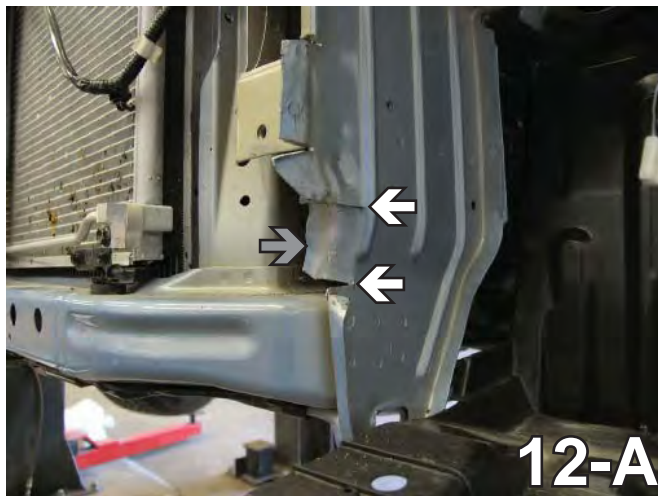

12. Using a reciprocating saw, make the first cut on the front of the tie down support webbing just above the radiator cross member and back to first rib, as indicated by the lower white arrow in 12-A. Do this to both sides of the vehicle. Make the second cut on the support webbing bend, just above first cut back to first rib, as indicated by the upper white arrow in 12-A. Bend webbing between the first two cuts in toward the radiator as far back as possible, as indicated by the grey arrow in 12-A. Do this to both sides of the vehicle. Make the third cut on the support webbing's second bend just above last cut, no deeper than the support webbing, as indicated by the lower white arrow in 12-B. Do this to both sides of the vehicle. Make the last cut on support webbing even with the bottom of the frame opening on the end of the frame rail, no deeper than support webbing, as indicated by the upper white arrow in 12-B. Bend webbing forward then flat with the tie down support, as indicated by the grey arrow in 12-B. Do this to both sides of the vehicle. This will prepare are for baseplate installation.

BX3519

2005 Suzuki Aerio

Installation Instructions

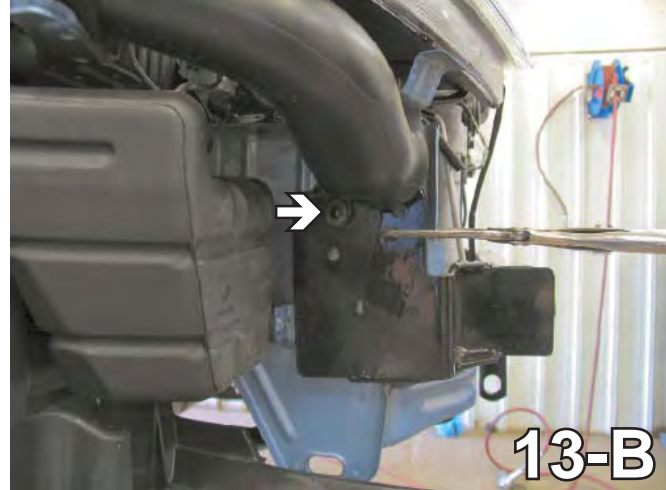

13. Slide the baseplate on the outside of tie down support where webbing was cut and align driver's side of baseplate with existing hole for front washer reservoir bolt location. Install existing reservoir bolt on driver's side, to hold baseplate in place as indicated in 13-A. Align the top middle hole of baseplate on the passenger's side with the existing hole in frame for air intake tube and clamp in place with the vise grip as indicated by 13-B. This will prepare the baseplate for drilling.

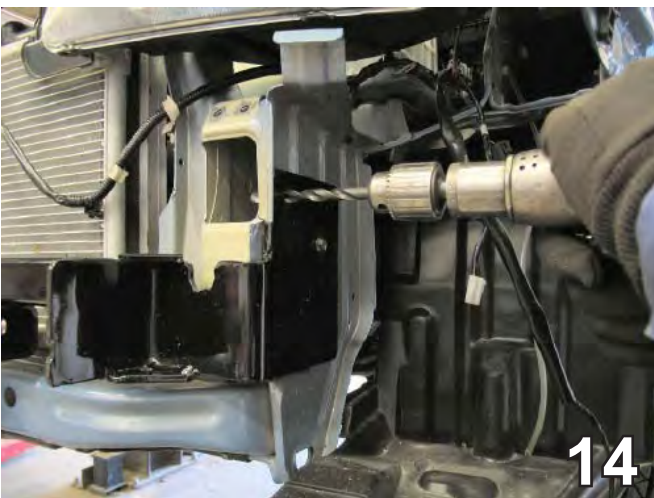

14. Using the baseplate as a template, drill all holes into the frame with the 13/32" drill bit. Do this to both sides of the vehicle.

15. Insert the double nut plate into the opening on the end of the frame rail to align with the top two drilled holes, hand tighten the two 3/8-16 hex bolts and lock washers. Do this to both sides. Slide the spacers between frame and baseplate with notch down and on top of the bolts. Slide the spacers between frame and baseplate with notch down and on top of bolts. Do this to both sides of the vehicle. Tighten the top two bolts, on both sides. Insert the nut plate into opening to align with lower drilled hole, tighten 3/8-16 hex bolt and lock washer. Do this to both sides of the vehicle.

****BE SURE TO USE LOCTITE® RED ON ALL BOLTS BEFORE TIGHTENING. TIGHTEN ALL BOLTS ACCORDING TO THE TORQUE CHART ON PAGE 1 OF THESE INSTRUCTIONS OR ON PAGE 3 OF THE BASEPLATE TOWING GENERAL INSTRUCTIONS.**

BX3519

2005 Suzuki Aerio

Installation Instructions



16. Set metal bumper upside down on bench, as shown in 16-A. Cut inside webbing with a reciprocating saw. Do this to both sides of the vehicle. Using the vise grips, bend webbing flat with the bottom of metal bumper see 16-B. Do this to both sides of the vehicle.

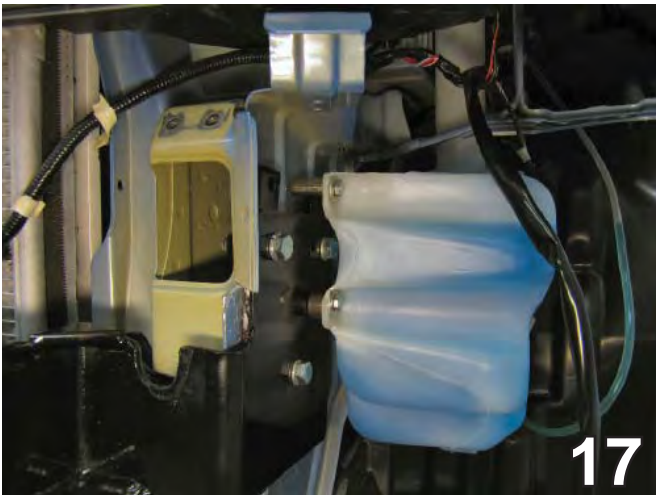

17. Reinstall washer reservoir using the 6MM hex bolt, 1" spacer tube, 1/2" spacer tube, and 1/4" flat washers provided for the front two bolt locations and the existing bolt for the back bolt location on the driver's side.

Be sure that ALL electrical connections are plugged in properly and functioning BEFORE Installing the fascia.

18. Reinstall front fascia according to the instructions on the previous pages (Steps 1-9).
19. Install the tow bar and safety cables according to the instructions when demonstrating this to the customer. Be sure to include all the contents and packages of their Blue Ox products.
20. **DO NOT** substitute other devices if the tow bar pins and clips are misplaced.

DEALER or INSTALLER:
Be certain the user receives the instructions sheets for their products.

BX3519

2005 Suzuki Aerio

Installation Instructions



With cap plugs installed.

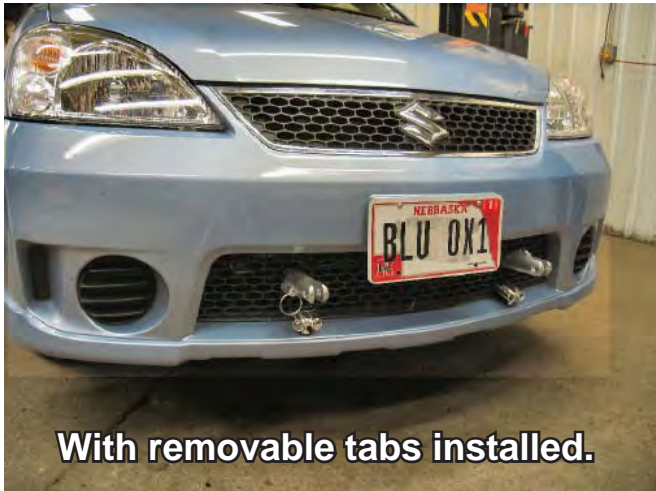

With removable tabs installed.

If the baseplate is in an accident, it must be replaced. DO NOT use it again! An accident can cause unseen damage and using it again could result in more damage or serious injury. DO NOT use the baseplate if it is damaged or missing parts.

Customer Service Commitment

Blue Ox is committed to providing you with exceptional customer care throughout your lifetime with our products. Our team is here to assist you with any questions you may have regarding the performance of your product. Simply call (402) 385-3051 and you can speak with our customer care team.

Additionally, please visit our website to see which rallies our Destination America team will be attending. For a nominal fee, our service technician will service your towing system to ensure it's in proper working condition. Also as a commitment to our customers, should you visit our factory you can stay at our full service Blue Ox campground at no charge along with enjoying a factory tour.

Again thank you for being our customer and for the confidence you have shown in the performance of our products. It is because of customers like you we enjoy the success we have today.



© 2005, 10 Blue Ox
One Mill Road, Industrial Park
Pender, Nebraska 68047
Phone: (402) 385-3051
Fax: (402) 385-3360
www.blueox.com