



BX3770
 2006-10 Toyota RAV4
 & 2011-13 RAV4 Sport
 Installation Instructions

Serial Number

Please read BOTH these Installation Instructions and the General Towing Instructions before attempting to install or operate this equipment.

- Blue Ox® towing products and accessories are intended to be installed by Blue Ox® Dealers who are familiar with our products and have the equipment and knowledge to do “fit work”. When necessary, Blue Ox® Dealers can be found at www.blueox.com or by contacting our Customer Care Department at (402) 385-3051.
- Many Blue Ox® Baseplates are designed to use existing holes and hardware to mount the baseplate to the towed vehicle. Even though bolts are there, do not assume they are adequate for baseplate mounting. Always use hardware supplied in the hardware kit or existing hardware specified in the Baseplate Installation Instructions.

Attachment Tab Height: 24”
 Attachment Tab Width: 22”

Bolt Torque Specifications
 Torque in Foot-Pounds for Metric Bolts

Bolt Size	Grade 8.8	Grade 10.9
6MM	6	8
8MM	16	22
10MM	31	40
12MM	54	70
14MM	89	117

Confirm the towability and pre-towing procedures for your vehicle with the owner’s manual or contact the vehicle’s manufacturer for specific towing procedures.

Bolt Torque Specifications
 Torque in Foot-Pounds for Inch Bolts

Bolt Size	Grade 5	Grade 8
1/4”	10	14
5/16”	19	29
3/8”	33	47
7/16”	54	78
1/2”	78	119
5/8”	154	230



If the front of your vehicle looks different than this, call us at (402) 385-3051.

! WARNING

Failure to read and follow these instructions could result in separation of the towed vehicle from the tow bar, causing property damage, loss of towed vehicle, personal injury or death.

BX3770

2006-10 Toyota RAV4 & 2011-13 RAV4 Sport

Parts List

Ref. No.	Qty.	Part #	Description
1	1	61-6294	Weldment, Base Plate, BX3770
2	1	101-6979	Plate End, DS, BX3770
3	1	101-6980	Plate End, PS, BX3770
4	8	201-0443	3/8-16 x 1" Bolt, Grd. 5, ZP
5	4	201-0011	1/2-13 x 1 1/4" Bolt, Grd. 5, ZP
6	4	203-0012	1/2" Lock Washer
7	2	202-0005	1/2-13 Hex Nut, ZP
8	6	203-0010	3/8" Lock Washer
9	8	202-0003	3/8-16 Hex Nut
10	2	201-0553	1/4-20 x 1/2" Hx. Wshd, Type F Screw
11	2	201-0192	#10-32 x 1/2" Slot, Rd. Hd. Screw
12	2	203-0054	#10 Lock Washer
13	2	202-0047	#10-32 Hex Nut
14	2	101-5822	Adapter, 4 Way Connector
15	2	62-3468	Attachment, Assembly, SF/SB (R)
	2	226-0046	Baseplate Safety Cable, 36" CL III (Not Shown)
	4	229-0359	Quicklink, 3/8, ZP (Not Shown)
	2	290-0437	Cap Plug, Blk. (Not Shown)

Tools Required

- Loctite® RED
- 9/16" Socket
- 3/4" Socket
- Flat Screwdriver
- Reciprocating Saw
- Vise Grips
- Hack Saw Blade
- 13/32" Carbide Drill Bit

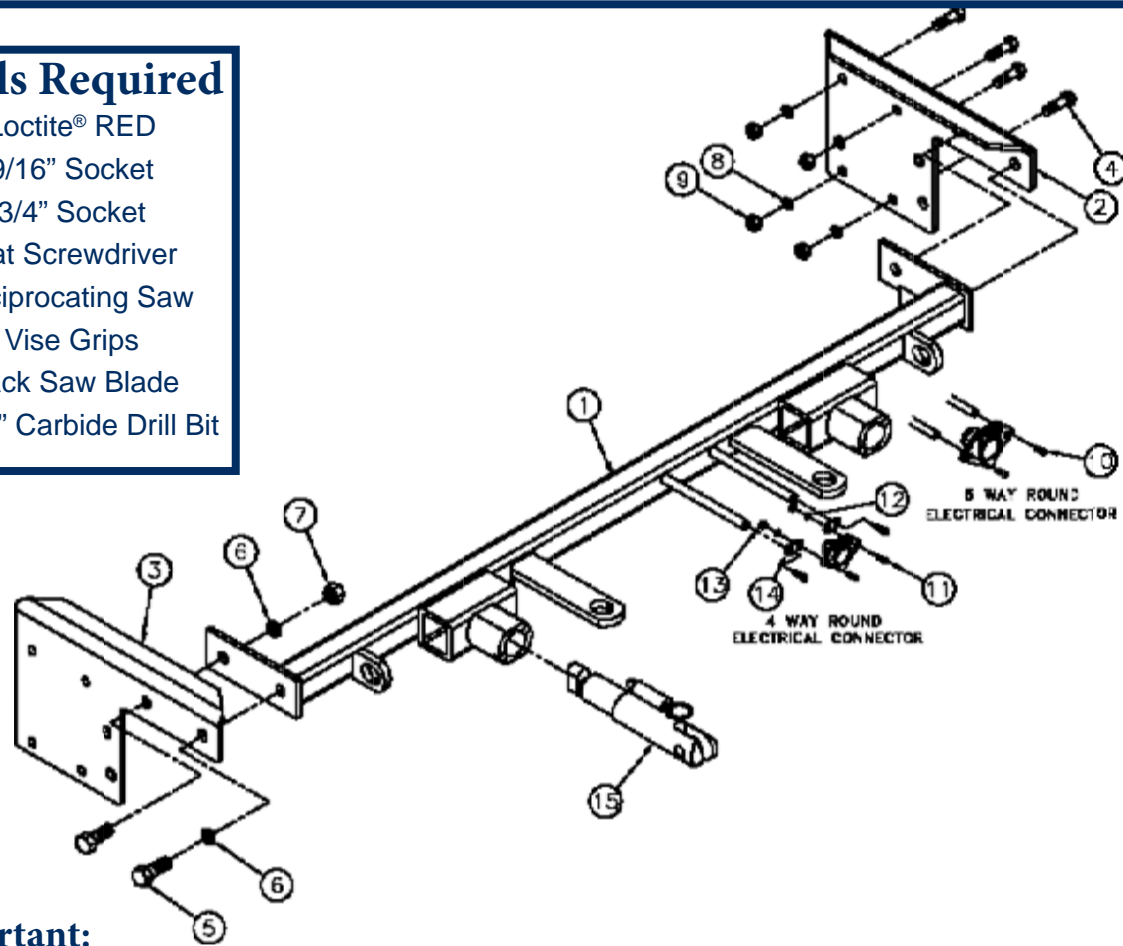

Important:

Use only genuine factory replacement parts on your baseplate. Do **NOT** substitute homemade or non-typical parts. If a bolt is lost or in need of replacement, for your safety and the preservation of your baseplate, be sure to use a replacement bolt of the same grade (In most cases it will be Grade 5, please reference the parts list above). Replacement parts may be ordered through your nearest Blue Ox® Dealer or Distributor. Failing to follow and/or altering these installation instructions in either installation or required equipment will void the manufacturer's warranty.

BX3770

2006-10 Toyota RAV4 & 2011-13 RAV4 Sport

Attachment Tabs:

Due to the design of removable tabs, the RangeFinderII, Acclaim and Ambassador tow bars can not be used. Adapters, except the BX8833 and BX88151, can not be used with this baseplate.

Installation Notes: The radiator cover, belly pan, fascia, air baffle, washer reservoir, fascia support molding, styrofoam and horns are removed for installation. Trimming of the grille style and drilling are required.

The dimensional variations between otherwise identical vehicles can be considerable.

While the baseplate was designed for easy installation, it may be necessary to tailor the baseplate slightly to compensate for auto manufacturer's tolerances. These minor adjustments may include filing a hole slightly, bending electrical rods or bending end plates.

The BX8848 4-Diode Wiring Kit is recommended for this vehicle.

Handling of some cosmetic parts when installing this product may require the use of protective covers, rags, specialty tools, etc. to prevent damage.

Installation Instructions:

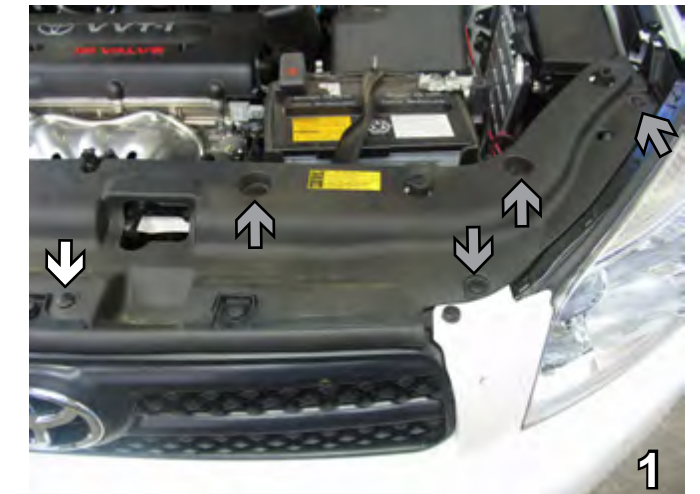

1. Remove four pushpins from the radiator cover (see grey arrows). Do this to both sides of the vehicle. Remove one pushpin near the front and center of radiator cover (see white arrow). Pull up on radiator cover to remove. Set pushpins and radiator cover aside to be reinstalled later.



2. Remove two pushpins from the upper corners of fascia (see grey arrows). Above the grille, remove two pushpins from the top of fascia (see white arrows). Set pushpins aside to be reinstalled later.

BX3770
2006-10 Toyota RAV4 & 2011-13
RAV4 Sport



3. On outside edge of wheel well, turn screw 90 degrees with the flat screwdriver to remove. Do this to both sides of the vehicle. Set screws aside to be reinstalled later.

4. Push wheel well cover aside to expose top edge of fascia. Remove one metric bolt using the 10mm socket. Do this to both sides of the vehicle. Set bolts aside to be reinstalled later.

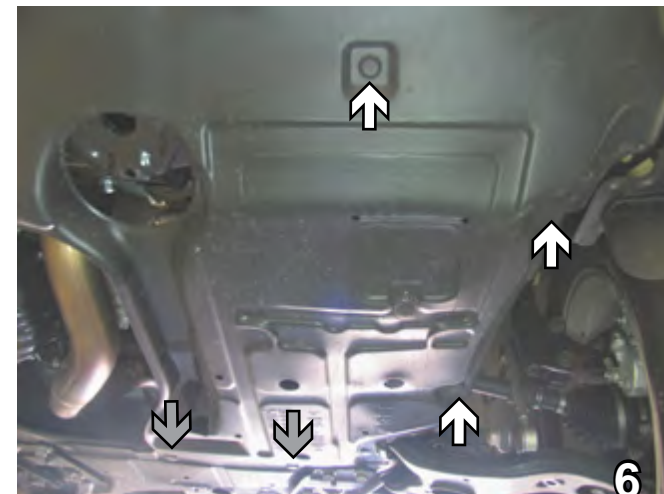
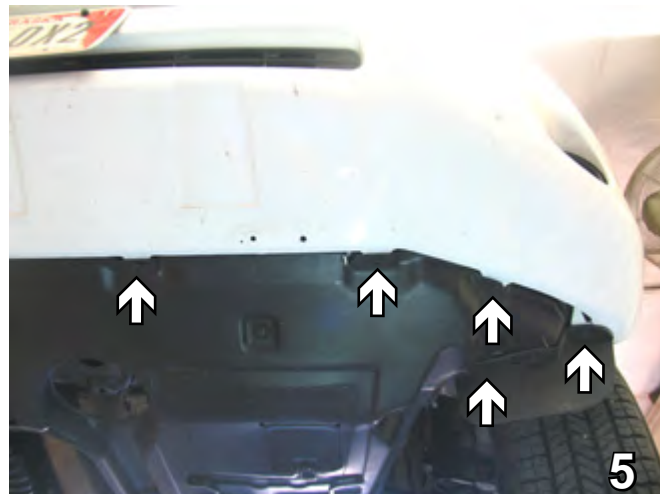

5. Along the bottom edge of fascia, remove five pushpins (three in the center and two from each tire guard) using the 10mm socket. Do this to both sides of the vehicle. Set pushpins aside to be reinstalled later.

6. Remove five pushpins from the belly pan's driver's side (shown). Remove three pushpins from the passenger's side. Pushpins with grey arrows are found on driver's side only. Pull belly pan down to remove. Pull fascia forward to remove. Set belly pan, fascia and pushpins aside carefully to be reinstalled later.

BX3770
2006-10 Toyota RAV4 & 2011-13
RAV4 Sport



7. On the driver's side, use the 10mm socket to remove two metric bolts from the air baffle brackets. Remove air baffle. Set bolts and air baffle aside to be reinstalled later.

8. On the passenger's side, disconnect electrical connections from the side of washer reservoir and plug the reservoir. Push wheel well cover aside to remove one metric bolt behind the reservoir (see upper white arrow) using the 10mm socket. Remove one metric bolt from the side reservoir bracket (lower white arrow) using the 10mm socket. Set bolts aside to be reinstalled later. If applicable, disconnect fog lights.

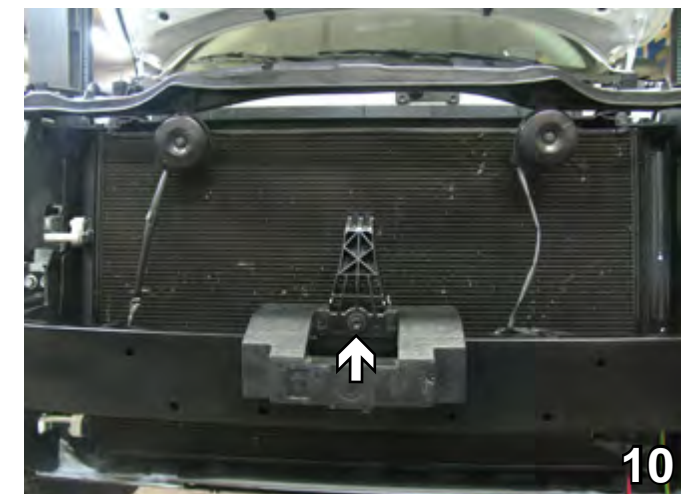

9. Disconnect the tube from the top of washer reservoir (see white arrow). Using the 10mm socket, remove one metric bolt from the lower bracket of reservoir. Remove washer reservoir. Set bolts and reservoir aside to be reinstalled later.

10. Using the 10mm socket, remove one metric bolt from the fascia support molding on top of the metal bumper. Remove fascia support molding and the styrofoam around it. Set both aside to be reinstalled later.

BX3770
2006-10 Toyota RAV4 & 2011-13
RAV4 Sport



11. Disconnect the electrical connection from the horn by pressing its tab to release it. Do this to both sides of the vehicle. Set the horn's electrical cables aside to clear the area for baseplate installation and to be reinstalled later.

12. On the air dam, mark a 3" vertical line that is 4 1/4" inches from the front of the air dam. Mark two horizontal lines that reach the front of air dam. The lower line runs above the bottom rib (flush with the bumper). Using the hack saw, cut the marked area. *Note: Do not remove the bottom or side rib - cut above or to the inside of the rib.* Do this to both sides of the vehicle.

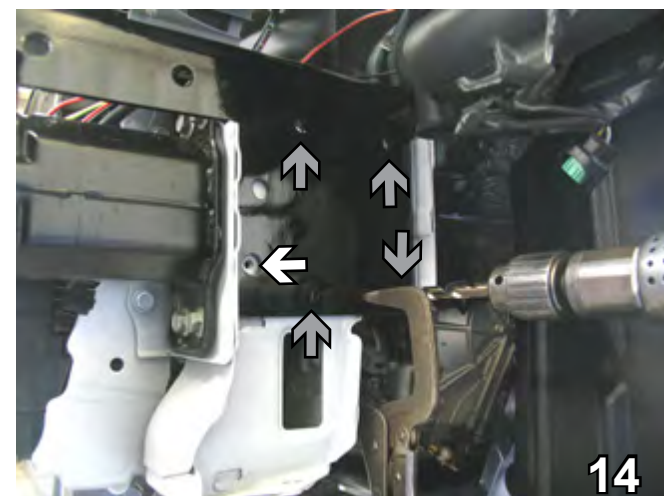

13. Mark a 1 1/2" vertical line starting on the front of the frame rail, flush with the side of the frame rail, moving down over the bumper bracket. Then, mark horizontally from the bottom of the vertical line to the outside of frame rail. Using the reciprocating saw, cut the marked area.

14. Align bottom of the endplate flush with the bottom of the frame and with the pre-existing hole of the frame (see white arrow). The endplate's angled top edge points to radiator. Clamp with vise grips. With the endplate as a template, drill four holes into frame (see grey arrows) using the 13/32" Carbide drill bit. Do this to both sides of the vehicle.

When using power drills be aware of the dangers of torque and drill bit length.

BX3770
2006-10 Toyota RAV4 & 2011-13
RAV4 Sport



15. Insert 3/8" lock washers and 3/8-16 hex nuts through frame rail opening (see grey arrow) and align to drilled holes. Insert 3/8-16 x 1" bolts and hand tighten (don't use Loctite yet). Do this to both sides of the vehicle.

BE SURE TO USE LOCTITE® RED ON ALL BOLTS BEFORE TIGHTENING. TIGHTEN ALL BOLTS ACCORDING TO THE TORQUE CHART ON THE FRONT PAGE OF THESE INSTRUCTIONS OR ON PAGE 3 OF THE BASEPLATE TOWING GENERAL INSTRUCTIONS.

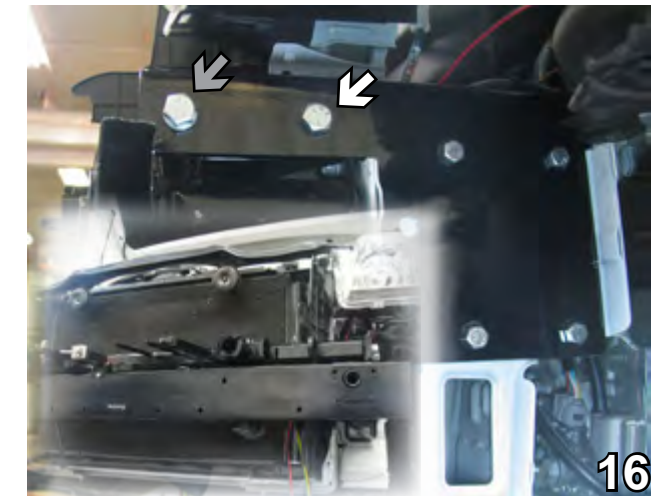

16. Place baseplate between the endplates (see inset). Insert 1/2-13 x 1 1/4" bolts into the endplate's upper holes. Tighten the forward most bolt (see grey arrow) and 1/2" lock washer to the weld nut in the cross-tube. Tighten the other upper bolt (see white arrow) to the 1/2" lock washer and 1/2-13 hex nut. Remove the remaining four bolts, apply Loctite, reinsert and tighten. Do this to both sides of the vehicle.



17. Reinstall the air baffle. The brackets are in their original position, but the left side bracket is now over the endplate.



18. Before reinstalling the washer reservoir, using a hack saw blade cut the tab off as shown by the dotted line.

BX3770
2006-10 Toyota RAV4 & 2011-13
RAV4 Sport

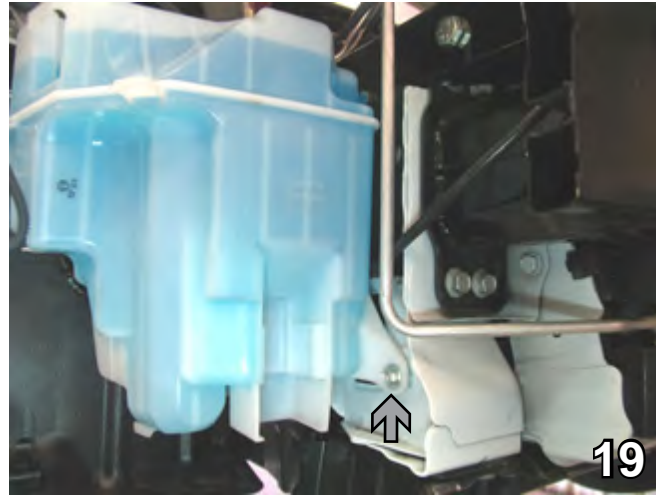

19. When reinstalling the washer reservoir, use three 1/4" flat washers for the lower bolt - between the frame and the reservoir.

20. With the fascia on a hard, flat surface, use the hack saw blade to remove the second rib in from the outside edge of the grille style.

21. Reinstall the fascia support molding and styrofoam, horns, belly pan, radiator cover, fascia, bolts, screws and pushpins.

Install the tow bar and safety cables according to the instructions provided in their packages. When demonstrating this to the customer, be sure to include all the contents and packages.

Do **NOT** substitute other devices if the tow bar pins and clips are misplaced.



22. Attach the permanent baseplate safety cables to the provided convenience link on the baseplate (see grey arrow). The photo above shows the recommended installation of the cables to frame of vehicle (see white arrow). Additional options may interfere with suggested mounting; in this case secure the cables to a solid piece of the frame as described in the instructions included with the permanent baseplate safety cables. Be sure the safety cables do not rub against any hoses or moving parts. Do this to both sides of the vehicle.

Be sure that **ALL** electrical connections are plugged in properly and functioning **BEFORE** installing the fascia.

BX3770
2006-10 Toyota RAV4 & 2011-13
RAV4 Sport

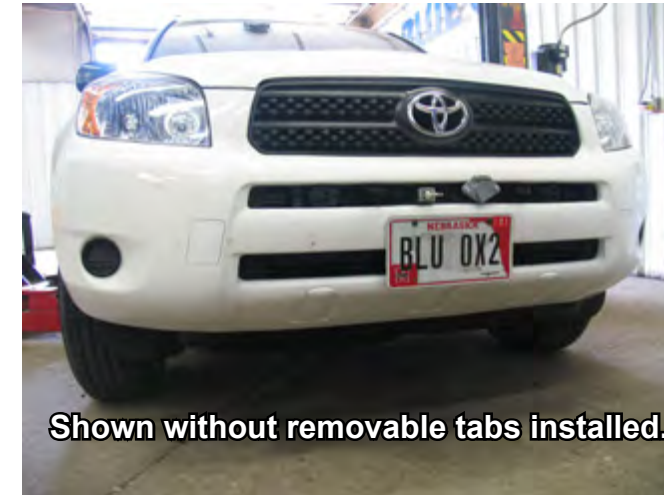

Shown without removable tabs installed.

DEALER or INSTALLER:

Be certain the user receives the instruction sheets for their products.



Shown with removable tabs installed.

If the baseplate is in an accident, it must be replaced. DO NOT use it again! An accident can cause unseen damage and using it again could result in more damage or serious injury. DO NOT use the baseplate if it is damaged or missing parts.

CUSTOMER SERVICE COMMITMENT

Blue Ox is committed to providing you with exceptional customer care throughout your lifetime with our products. Our team is here to assist you with any questions you may have regarding the performance of your product. Simply call (402) 385-3051 and you can speak with our customer care team.

Additionally, please visit our website to see which rallies our Destination America team will be attending. For a nominal fee, our service technician will service your towing system to ensure it's in proper working condition. Also as a commitment to our customers, should you visit our factory you can stay at our full service Blue Ox campground at no charge along with enjoying a factory tour.

Again thank you for being our customer and for the confidence you have shown in the performance of our products. It is because of customers like you we enjoy the success we have today.



© 2006, 07, 09, 10, 11 Blue Ox
One Mill Road, Industrial Park
Pender, Nebraska 68047
Phone: (402) 385-3051 • Fax: (402) 385-3360
www.blueox.com