

2015 Tahoe, Suburban 1500 Grille Guard Installation Instructions. Part # 200-21-5003 (Sensor Models), Part # 200-21-5004 (No Sensors)
 2015 GMC Yukon, Yukon XL Grille Guard Installation Instructions. Part # 200-31-5003 (Sensor Models), Part # 200-31-5004 (No Sensors)

Important: This unit will NOT fit vehicles equipped with 'adaptive cruise' option

Bolt Bag Contents:	
Quantity	Description
12	1/2" X 1 3/4" Bolts
24	1/2" Flat Washers
12	1/2" Lock Washers
12	1/2" Hex Nuts
2	steel plate washers
2	Frame Horn Brackets
64	Total Pieces

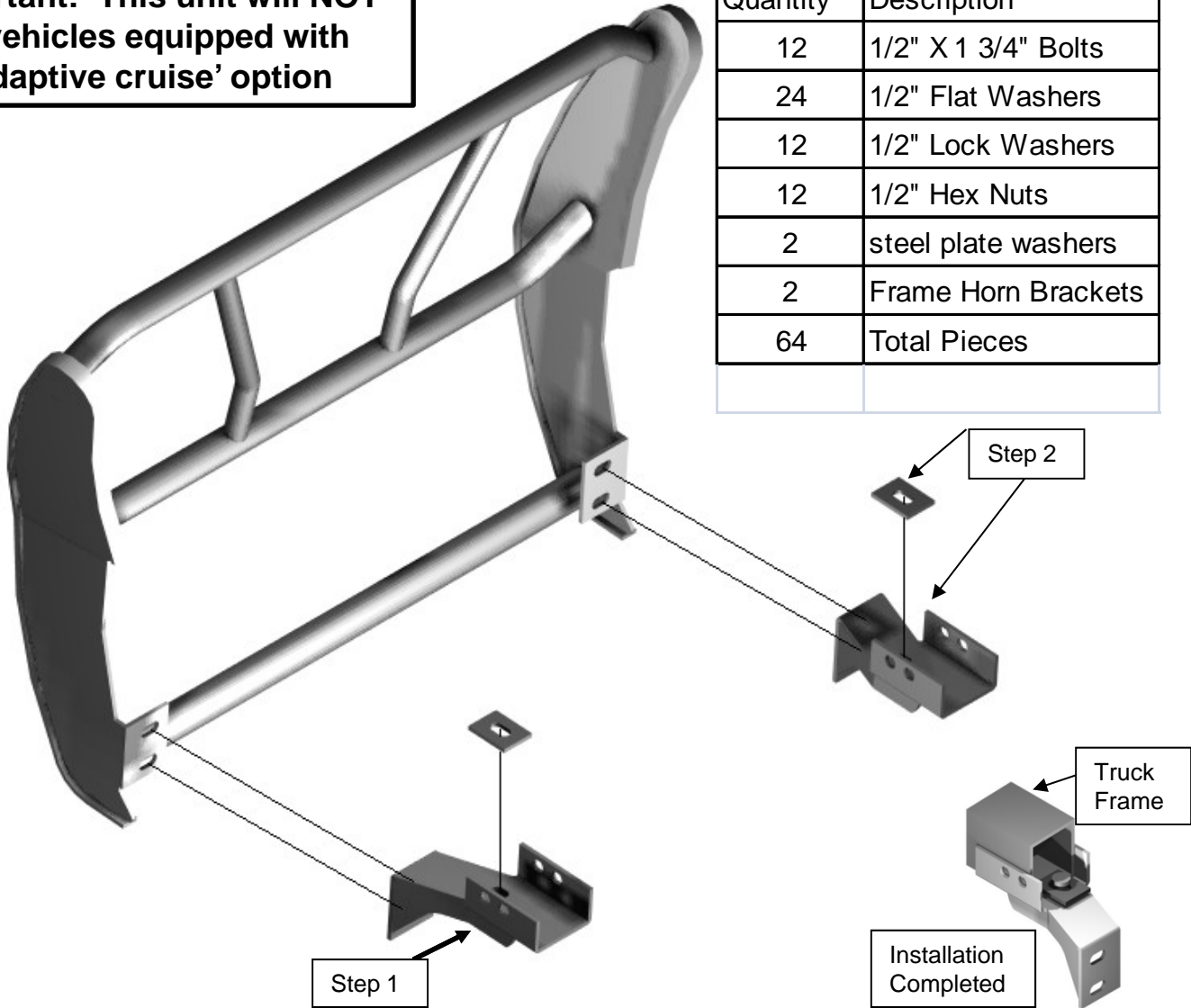

Step 1: Remove factory tow hooks if the truck has them. **IMPORTANT:** If truck does NOT have tow hooks you will need to cut an access hole through plastic valence in order to mount our bracket to the end of truck frame. Mount Frame Horn Bracket as shown in the picture using the holes in the end of frame. **ATTENTION:** space is tight so work from the back to front when putting in bolts and be sure to push bracket toward vehicle as far as it will go!!

Step 2: In order to secure bracket as tight as possible you must install our 1/2" bolt through the pre-punched hole on top of the bracket and squeeze bracket tightly to the tip of frame using the steel plate provided as a washer.

Step 3: Once brackets are tight to vehicle frame you can attach the Grille Guard feet to the brackets using the provided bolts.

Step 4: Check alignment of Grille Guard to truck before tightening bolts on the feet.