

STANDARD INSTALLATION FOR ALL VEHICLES (NOTE) THE BRACKET SYSTEMS ARE UNIQUE TO YOUR VEHICLE, SEE BRACKET ASSEMBLY SUGGESTIONS BELOW AND LOCATIONS ON THE BACK PAGE

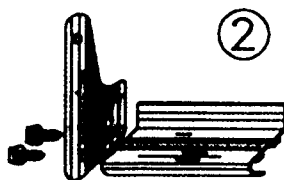

**1**  
BEND STONE GUARDS BY HAND AND KNEE TO FIT THE WHEEL WELL.



**2**  
FASTEN FRONT STONE GUARD TO BOARDS WITH 3/8" SELF TAPPING BOLT.



**3**  
SLIDE ONE OR TWO 1/4" x 5/8" SQUARE HEAD SCREWS INTO EACH TRACK (1 SET PER BRACKET) REFER TO DRAWINGS 11-14 FOR BRACKET LOCATION AND QUANTITY

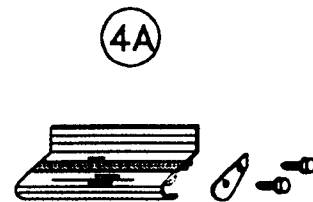

**4A**  
CAB LENGTH BOARDS  
INSTALL END CAP TO BOARD WITH 3/8" SELF TAPPING BOLT

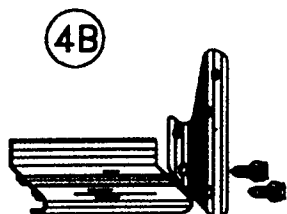

**4B**  
FULL LENGTH BOARDS  
BEND STONE GUARD BY HAND AND KNEE TO FIT WHEEL WELL. FASTEN REAR STONE GUARD TO BOARDS WITH 3/8" SELF TAPPING BOLTS.

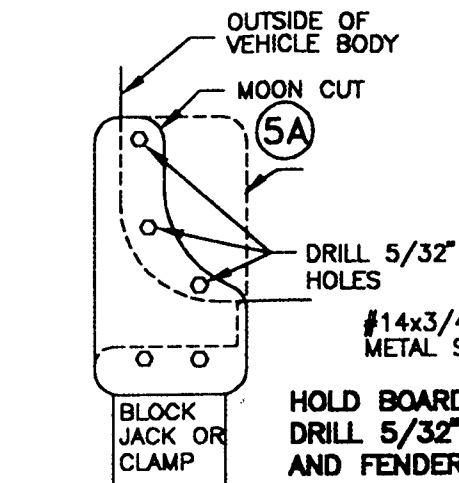

**5A**  
HOLD BOARD IN PLACE WITH BLOCKS OR CLAMPS DRILL 5/32" HOLES THROUGH THE STONE GUARD AND FENDER WELL ENLARGE THE STONE HOLE TO 7/32". FASTEN THE STONE GUARD TO THE VEHICLE WITH #14x3/4" SHEET METAL SCREWS.

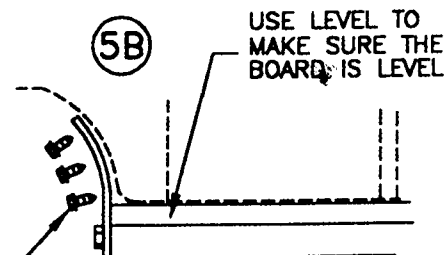

**TYPICAL BRACKET ASSEMBLY**

SUGGESTED BRACKET ASSEMBLYS, USE WHICH EVER FITS YOUR VEHICLE BEST

TYPICAL OLD FORD 87-96

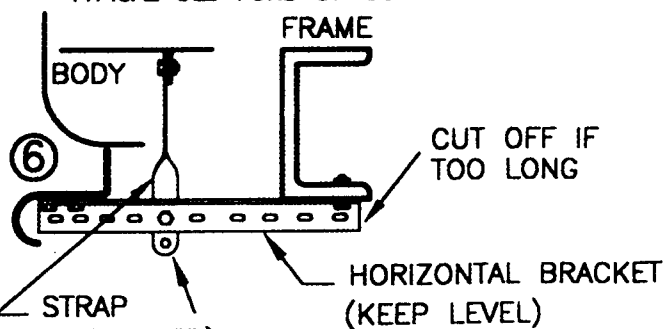

TYPICAL NEW FORD/GMC 96-CURRENT

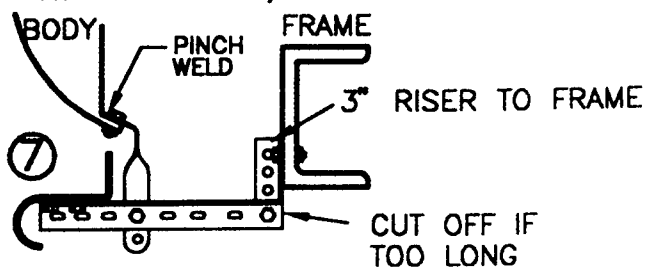

TYPICAL DODGE

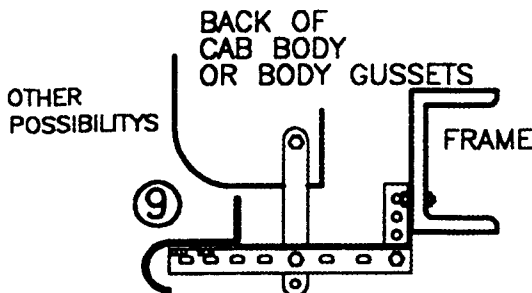
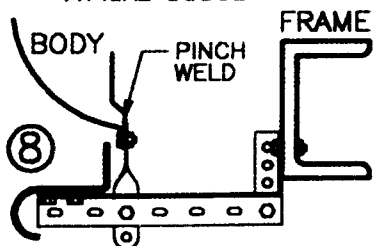

SEE BACK PAGE FOR TYPICAL BRACKET MOUNT LOCATIONS

⑩ TYPICAL SCREW TYPE AND APPLICATION

5/16" NUT AND BOLT

1/4" SQUARE HEAD BOLT, FLAT WASHER, LOCK WASHER AND NUT

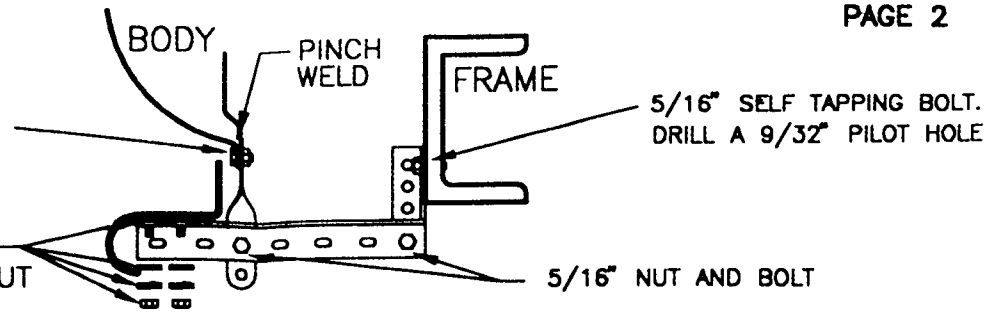

5/16" SELF TAPPING BOLT. DRILL A 9/32" PILOT HOLE

5/16" NUT AND BOLT

⑪

TYPICAL CAB LENGTH STD. CAB INSTALLATION

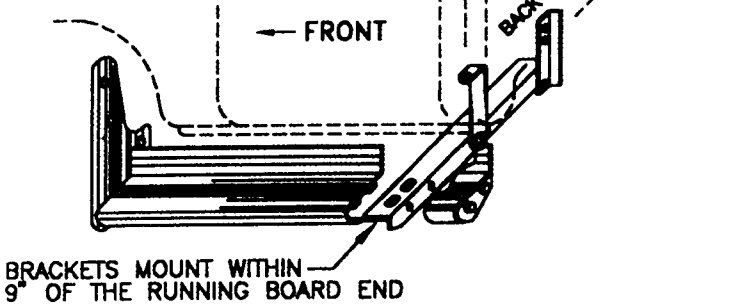

⑫

TYPICAL CAB LENGTH EXTENDED OR DOUBLE CAB INSTALLATION

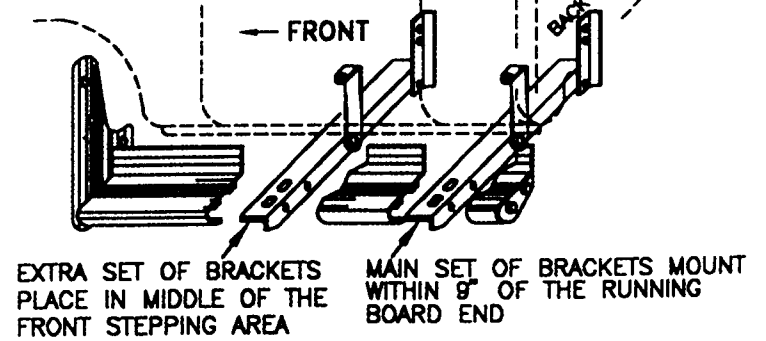

⑬

TYPICAL FULL LENGTH STD. CAB PICKUP AND VAN INSTALLATION

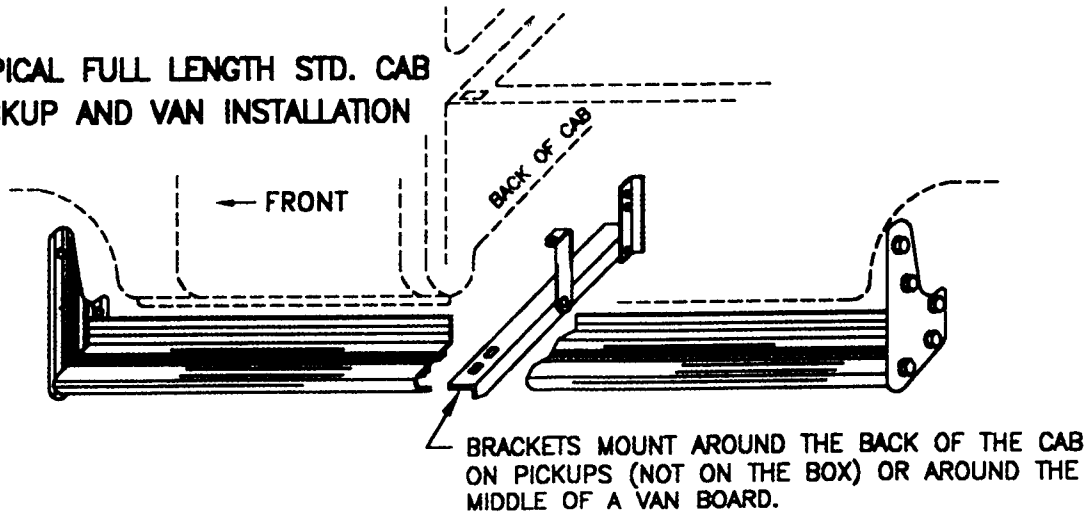

TYPICAL FULL LENGTH EXTENDED OR DOUBLE CAB PICKUP AND VAN INSTALLATION

⑭

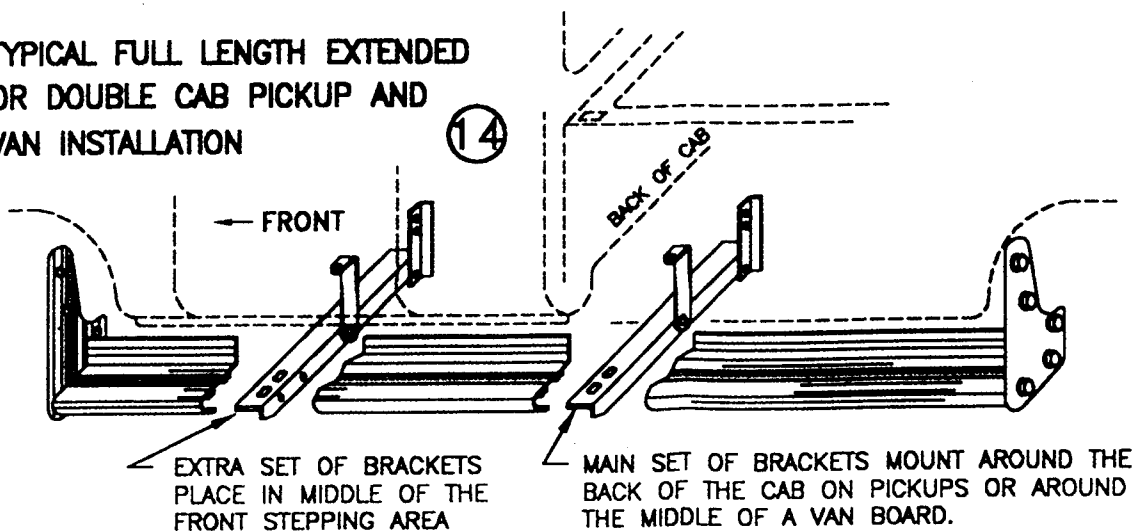

STANDARD INSTALLATION FOR ALL VEHICLES (NOTE) THE BRACKET SYSTEMS ARE UNIQUE TO YOUR VEHICLE, SEE BRACKET ASSEMBLY SUGGESTIONS BELOW AND LOCATIONS ON THE BACK PAGE

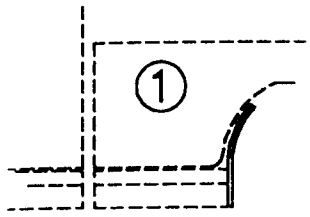

① BEND STONE GUARDS BY HAND AND KNEE TO FIT THE WHEEL WELL.

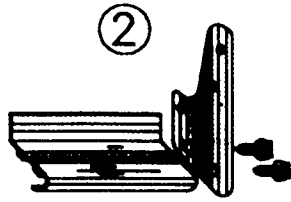

② FASTEN REAR STONE GUARD TO BOARDS WITH 3/8" SELF TAPPING BOLT.

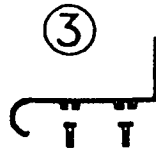

③ SLIDE ONE 1/4" x 5/8" SQUARE HEAD SCREWS INTO EACH TRACK REFER TO DRAWINGS 11-12 FOR BRACKET LOCATION

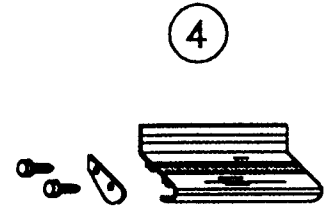

④ INSTALL END CAP TO BOARD WITH 3/8" SELF TAPPING BOLT

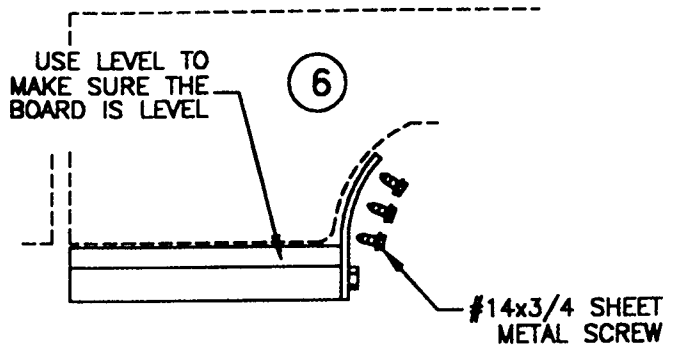
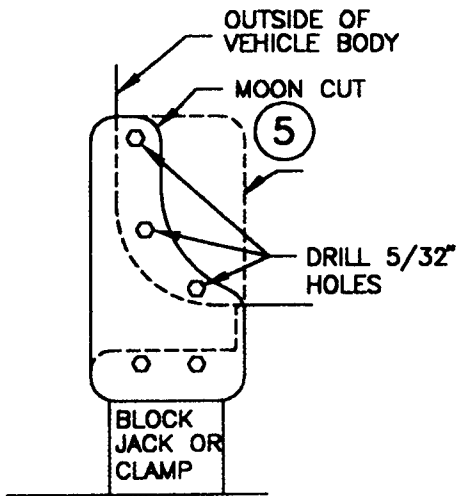

⑤ DRILL 5/32" HOLES

⑥ USE LEVEL TO MAKE SURE THE BOARD IS LEVEL

#14x3/4 SHEET METAL SCREW

HOLD BOARD IN PLACE WITH BLOCKS OR CLAMPS DRILL 5/32" HOLES THROUGH THE STONE GUARD AND FENDER WELL ENLARGE THE STONE HOLE TO 7/32". FASTEN THE STONE GUARD TO THE VEHICLE WITH #14x3/4" SHEET METAL SCREWS.

## TYPICAL BRACKET ASSEMBLY

SUGGESTED BRACKET ASSEMBLYS, USE WHICH EVER FITS YOUR VEHICLE BEST

TYPICAL OLD FORD 87-96

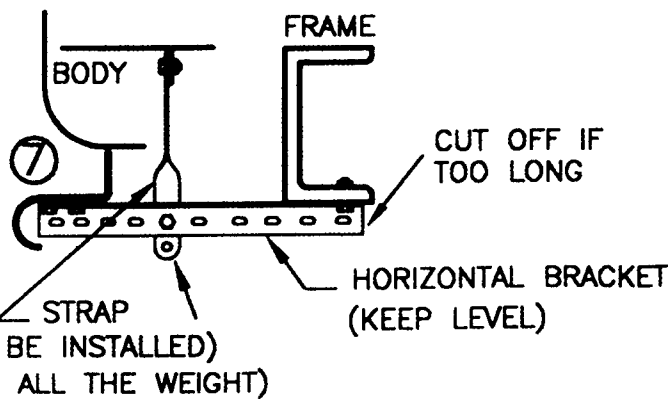

TYPICAL NEW FORD/GMC 96-CURRENT

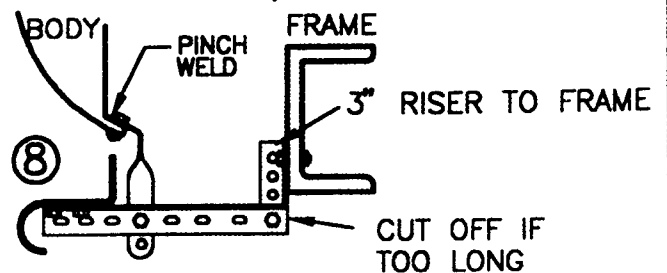

TYPICAL DODGE

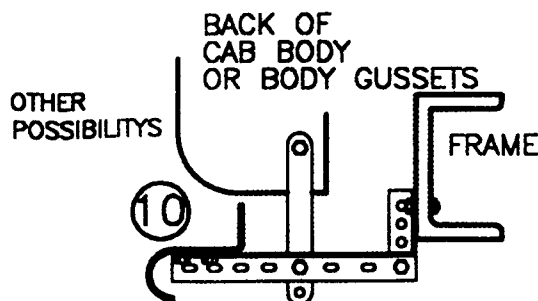
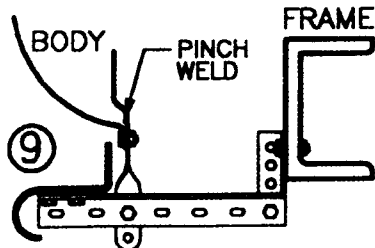

SEE BACK PAGE FOR TYPICAL BRACKET MOUNT LOCATIONS

11 TYPICAL SCREW TYPE AND APPLICATION

5/16" NUT AND BOLT

1/4" SQUARE HEAD BOLT, FLAT WASHER, LOCK WASHER AND NUT

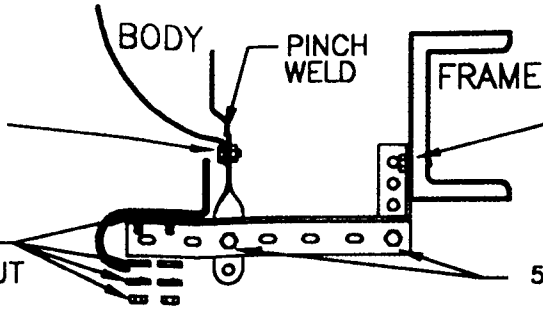

5/16" SELF TAPPING BOLT. DRILL A 9/32" PILOT HOLE

5/16" NUT AND BOLT

12

BED INSTALLATION

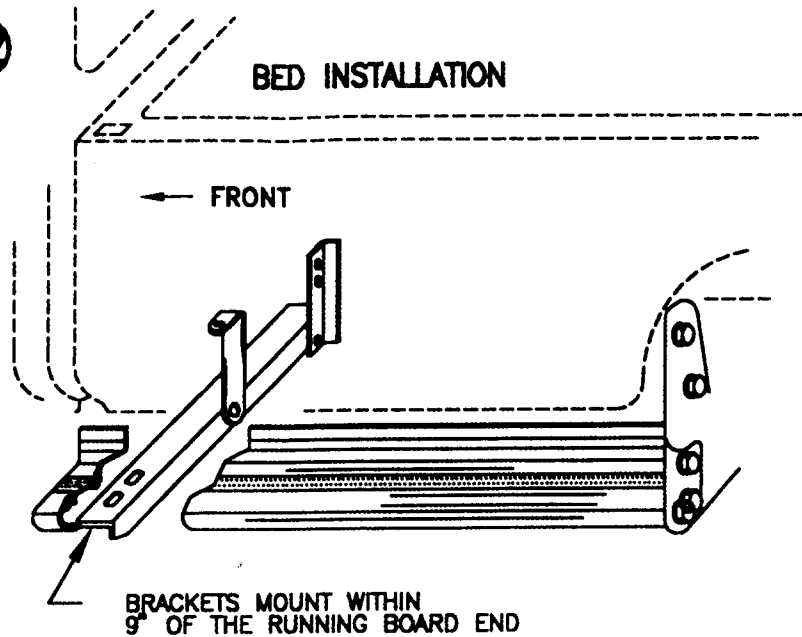

UNIVERSAL DUALY BOARD INSTALLATION

DUALYS MOUNT SIMILAR TO THE BOX BOARDS BUT WILL USE TWO SETS OF BRACKETS

13

DUALY BED

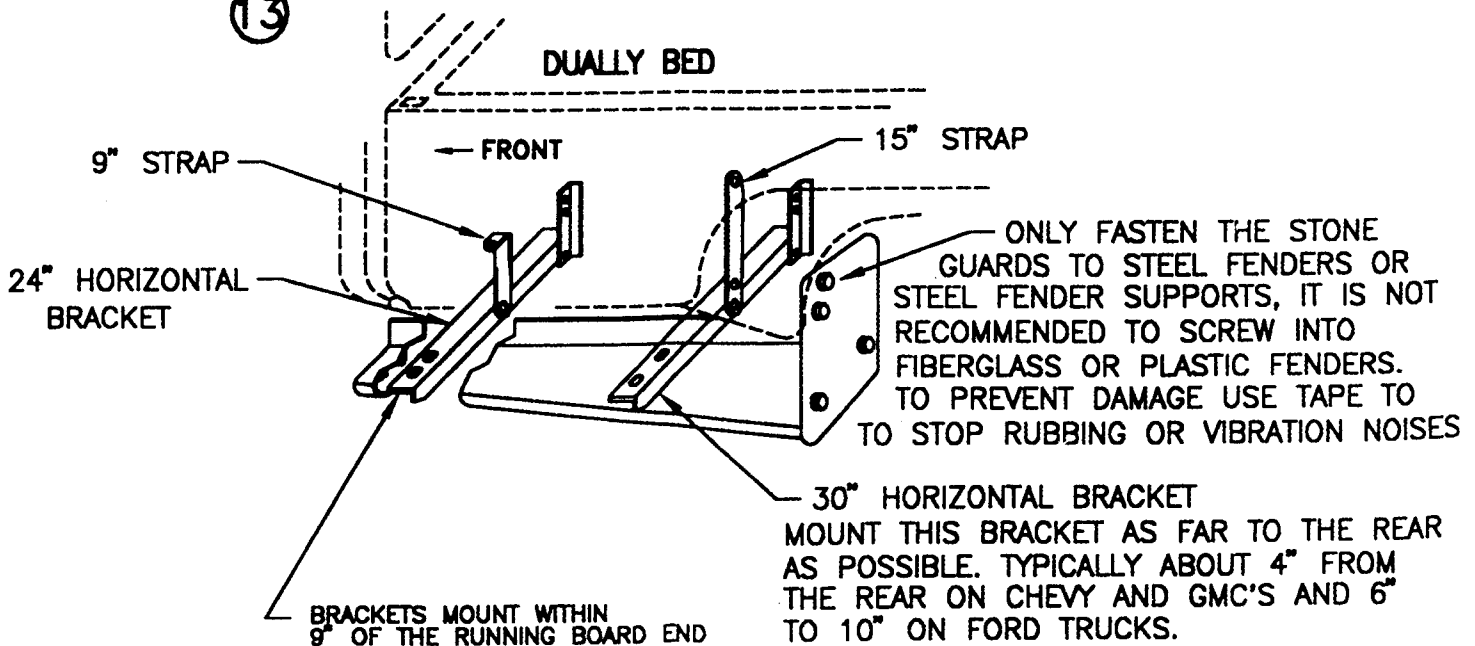

ONLY FASTEN THE STONE GUARDS TO STEEL FENDERS OR STEEL FENDER SUPPORTS, IT IS NOT RECOMMENDED TO SCREW INTO FIBERGLASS OR PLASTIC FENDERS. TO PREVENT DAMAGE USE TAPE TO STOP RUBBING OR VIBRATION NOISES

30" HORIZONTAL BRACKET MOUNT THIS BRACKET AS FAR TO THE REAR AS POSSIBLE. TYPICALLY ABOUT 4" FROM THE REAR ON CHEVY AND GMC'S AND 6" TO 10" ON FORD TRUCKS.