

DRILLING INTO BODY AND FRAME IS REQUIRED.

INSTALLATION PARTS LIST:

QTY.	DESCRIPTION	QTY.	DESCRIPTION
1	RUNNING BOARD	1	DRIVER & 1 PASSENGER
1	STONE GUARD	1	LEFT & 1 RIGHT
6	3/8"x1 SELF TAPPING SCREW	10	5/16" x 3/4" BOLT
6	#14x3/4" SHEET METAL SCREW	8	5/16-18 HEX WASHER HEAD NUT
4	1/4x5/8" SQUARE HEAD SCREW	2	FLAT BRACKET, FL74
4	1/4-20 HEX NUT	2	FLAT BRACKET, FL73 D&P
1	END CAP 1 LEFT & 1 RIGHT	2	HORIZONTAL BRACKET, SUPPORT, 3124F
		2	#14 X 3/4 TEK SCREW

TOOLS REQUIRED: 5/16" DRILL • 1/2" HEX SOCKET • 1/2" WRENCH • 5/16" NUT DRIVER • 3/8" NUT DRIVER

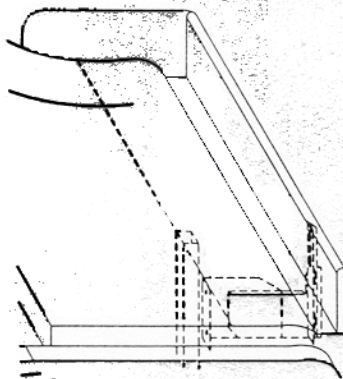

BOX BRACKET LOCATION
(DRIVERS SIDE SHOWN)

① LOCATE THE FIRST BED CROSS BRACE BEHIND THE CAB

② BRACKET ASSEMBLY ASSEMBLE WITH 5/16" BOLTS

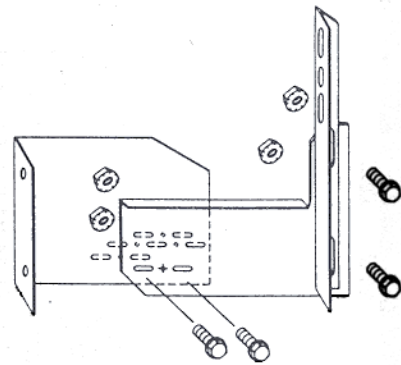

③ PREDRILL A 5/16" HOLE NEAR THE END OF THE CROSSBRACE. SLIDE NUT CUP INTO END OF CROSS BRACE AT BRACKET LOCATION

BRACKET ASSEMBLY MOUNT TO BED ASSEMBLY WITH 5/16" BOLTS AND NUT CUP AND #14 SELF DRILLING SCREW

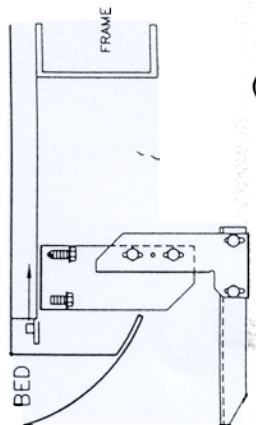

MOUNT AT LOCATION SHOWN AT ①

④ BEND STONE GUARD BY HAND AND KNEE TO FIT THE WHEEL WELL BEFORE INSTALLING TO RUNNING BOARD



FASTEN REAR STONE GUARD TO BOARDS WITH 3/8" SELF TAPPING BOLT. BEND STONE GUARD BY HAND AND KNEE TO FIT THE WHEEL WELL



⑦ INSTALL END CAP TO BOARD WITH 3/8" SELF TAPPING BOLT

⑥ SLIDE ONE 1/4"x5/8" SQUARE HEAD SCREW INTO EACH TRACK.

⑧ HOLD BOARD IN PLACE WITH THE FRONT RESTING ON THE BOX BRACKET. BE SURE THAT 1/4" BOLTS ARE PLACED INTO THE BRACKET STEP SUPPORT

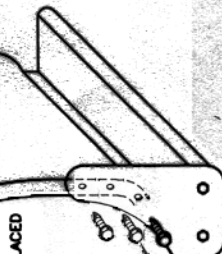

⑨ SCREW THROUGH STONE GUARD INTO FENDERWELL LIP USING #14 BY 3/4 SHEET METAL SCREWS. MAKE SURE YOU DRILL INTO METAL. 3 PLACES AT EACH STONE GUARD

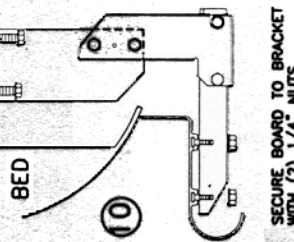

SECURE BOARD TO BRACKET WITH (2) 1/4" NUTS

⑩ WITH BOARD LEVEL TIGHTEN ALL LOOSE BOLTS

⑪ REPEAT FOR OTHER SIDE

NEWBOX
IN216
05/28/03

OWENS PRODUCTS • 1000 PROGRESS STREET • STURGIS, MI 49091 • 919-651-2300 • TOLL-FREE: 800-726-9367 • FAX: 919-651-9328 • WEB: www.owens-pro.com