



88-98 CHEVY/GMC CREW CAB

IN238A
02/15/04

DRILLING INTO BODY AND FRAME IS REQUIRED.

INSTALLATION PARTS LIST:	QTY.	DESCRIPTION
1	1	RUNNING BOARD 1 DRIVER & 1 PASSENGER
2	16	5/16" x 3/4" BOLT
3	16	5/16-18 HEX WASHER HEAD NUT
4	4	FLAT BRACKET, FL90
5	8	3/8" x 1 SELF TAPPING SCREW
6	12	#14x3/4" SHEET METAL SCREW
7	8	1/4x5/8" SQUARE HEAD SCREW
8	8	1/4-20 HEX NUT

TOOLS REQUIRED: 5/16" DRILL • 1/2" HEX SOCKET • 1/2" WRENCH • 5/16" NUT DRIVER • 3/8" NUT DRIVER

MEASURE FROM FRONT WHEEL WELL TO BRACKET LOCATION
MARK THIS DIMENSION ON THE PINCH WELD

(DRIVERS SIDE SHOWN)

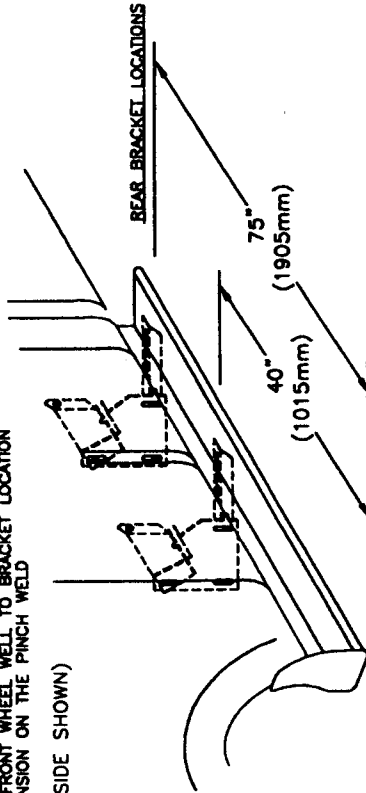

② BRACKET ASSEMBLY ASSEMBLE WITH 5/16" BOLTS LEAVE BOLTS LOOSE

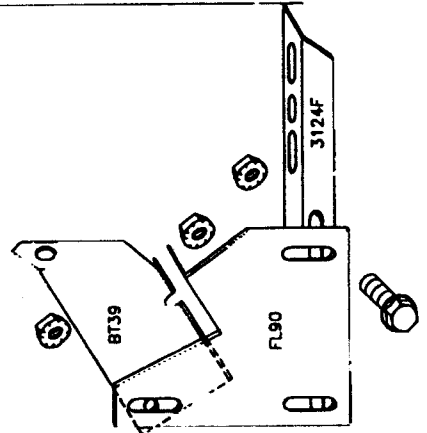

③ BRACKET ASSEMBLY MOUNT TO BODY ASSEMBLE WITH 5/16" BOLTS AND #14 SELF DRILLING TEX SCREWS
SLIDE BT39 AND FL90 OVER THE PINCH WELD FLANGE WITH BT39 UP AGAINST THE SIDE WALL, BOLT TIGHT TO THE PINCH WELD. INSERT ONE #14x3/4" SELF DRILLING SCREW THROUGH FL90 INTO THE PINCH WELD AND BT39

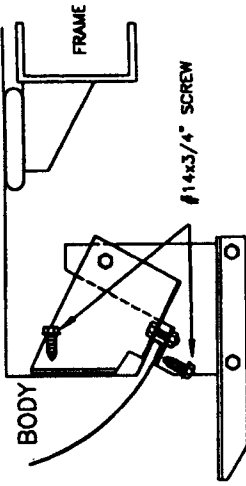

MOUNT AT LOCATION SHOWN AT ①

④ BEND STONE GUARD BY HAND AND KNEE TO FIT THE WHEEL WELL BEFORE INSTALLING TO RUNNING BOARD

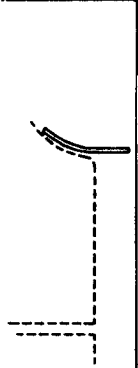

⑦ INSTALL END CAP TO BOARD WITH 3/8" SELF TAPPING BOLT

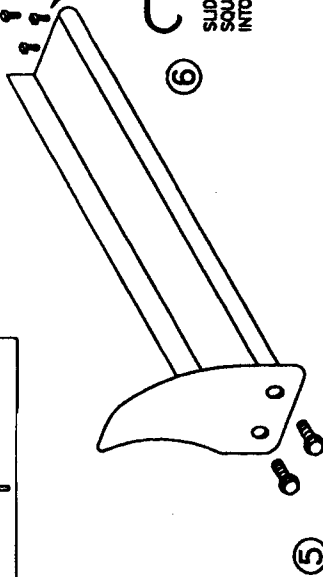

⑤ FASTEN FRONT STONE GUARD TO BOARDS WITH 3/8" SELF TAPPING BOLT. BEND STONE GUARD BY HAND AND KNEE TO FIT THE WHEEL WELL

⑥ SLIDE TWO 1/4x5/8" SQUARE HEAD SCREW INTO EACH TRACK.

⑧ HOLD BOARD IN PLACE WITH THE REAR RESTING ON THE BACK BRACKET

NOTE:
BE SURE THAT 1/4" BOLTS ARE PLACED INTO THE BRACKET STEP SUPPORT

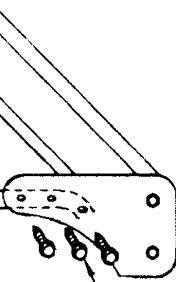

⑨ SCREW THROUGH STONE GUARD INTO FENDERWELL UP USING #14 BY 3/4 SELF DRILLING SCREWS. MAKE SURE YOU DRILL INTO METAL

3 PLACES AT EACH STONE GUARD

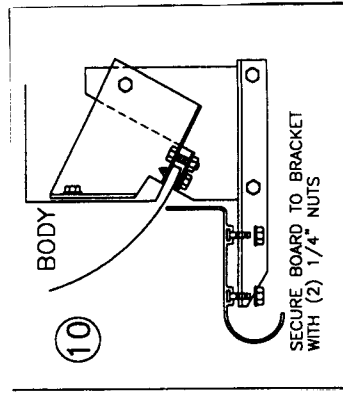

⑩ WITH BOARD LEVEL TIGHTEN ALL LOOSE BOLTS

⑪ REPEAT FOR OTHER SIDE

IN238A
02/15/04