



04-CURRENT F150 SUPERCREW

IN250 09/12/03

SOME BRACKETS INSTALL IN FACTORY HOLES

INSTALLATION PARTS LIST:	QTY.	DESCRIPTION
	1	RUNNING BOARD
	1	DRIVER & 1 PASSENGER
	2	5/16" CLIP NUT
	8	3/8"x1 SELF TAPPING SCREW
	8	#14x3/4" HEX SCREW
	8	1/4"x3/8" SQUARE HEAD SCREW
	8	1/4"-20 HEX NUT
	4	FLAT BRACKET, FLA3 4", FL86 2"
	4	HORIZONTAL BRACKET, SUPPORT, 3124F

TOOLS REQUIRED: 5/16" DRILL • 1/2" HEX SOCKET • 1/2" WRENCH • 3/16" NUT DRIVER • 3/8" NUT DRIVER

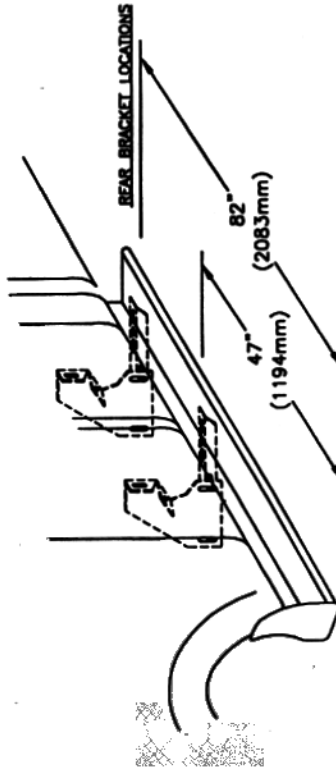

①
MEASURE FROM FRONT WHEEL WELL TO BRACKET LOCATIONS. MARK THIS DIMENSION ON THE PINCH WELD

②
BRACKET ASSEMBLY ASSEMBLE WITH 5/16" BOLTS

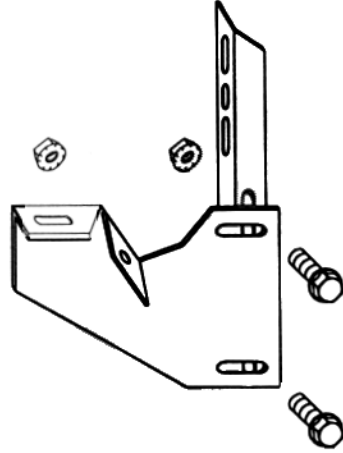

③
SLIDE NUT CLIP INTO BODY HOLES AT BRACKET LOCATION AT 0°

BRACKET ASSEMBLY MOUNT TO BODY 0° ASSEMBLE WITH 5/16" BOLTS AND NUT CLIP AND 5/16" BOLT

BRACKET ASSEMBLY MOUNT TO BODY 0° DRILL THROUGH PINCH WELD WITH A 5/16" DRILL ASSEMBLE WITH 5/16" BOLTS AND #14 SELF DRILLING SCREW

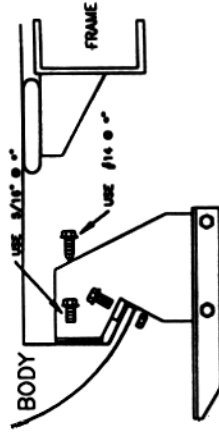

MOUNT AT LOCATION SHOWN AT ①

④
BEND STONE GUARD BY HAND AND KNEE TO FIT THE WHEEL WELL BEFORE INSTALLING TO RUNNING BOARD



⑦
INSTALL END CAP TO BOARD WITH 3/8" SELF TAPPING BOLT

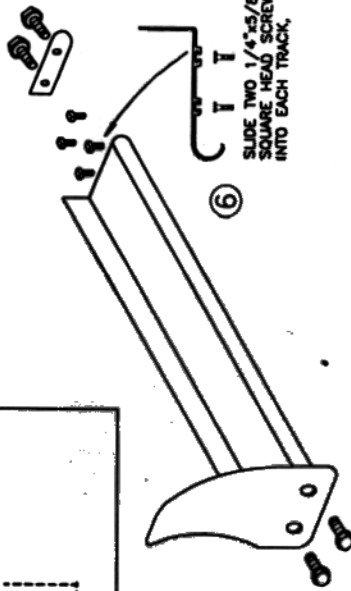

⑤
FASTEN FRONT STONE GUARD TO BOARDS WITH 3/8" SELF TAPPING BOLT. BEND STONE GUARD BY HAND AND KNEE TO FIT THE WHEEL WELL

⑥
SLIDE TWO 1/4"x5/8" SQUARE HEAD SCREW INTO EACH TRACK

⑧
HOLD BOARD IN PLACE, WITH THE REAR RESTING ON THE BACK BRACKET

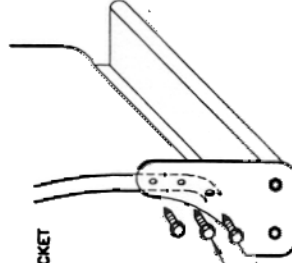

⑨
SCREW THROUGH STONE GUARD INTO FENDERWELL LIP USING #14 BY 3/4" SELF DRILLING SCREWS. MAKE SURE YOU DRILL INTO METAL

3 PLACES AT EACH STONE GUARD

NOTE: BE SURE THAT 1/4" BOLTS ARE PLACED INTO THE BRACKET STEP SUPPORT

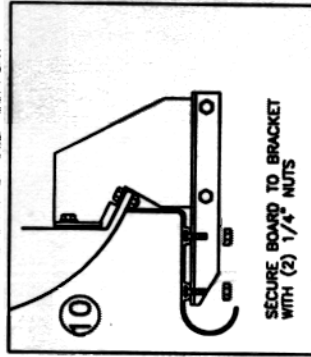

SECURE BOARD TO BRACKET WITH (2) 1/4" NUTS

⑪
WITH BOARD LEVEL TIGHTEN ALL LOOSE BOLTS

IN250 09/12/03

⑫ REPEAT FOR OTHER SIDE