



04-CURRENT F150 STANDARD CAB INZ61 08/30/04

SOME DRILLING IS REQUIRED

INSTALLATION PARTS LIST:	QTY.	DESCRIPTION	QTY.	DESCRIPTION
1	1	RUNNING BOARD	1	END CAP 1 LEFT & 1 RIGHT
1	2	STONE GUARD 1 LEFT & 1 RIGHT	2	5/16" CLIP NUT
8	14	3/8"x1 SELF TAPPING SCREW	12	5/16"x 3/4" BOLT
8	4	#14x3/4" TEK SCREW	4	FLAT BRACKET, FLBS 2", FL86 D&P 4"
8	4	1/4x5/8" SQUARE HEAD SCREW	4	HORIZONTAL BRACKET, SUPPORT, 3124F
8	4	1/4--20 HEX NUT		

TOOLS REQUIRED: 5/16" DRILL • 1/2" HEX SOCKET • 1/2" WRENCH • 5/16" NUT DRIVER • 3/8" NUT DRIVER

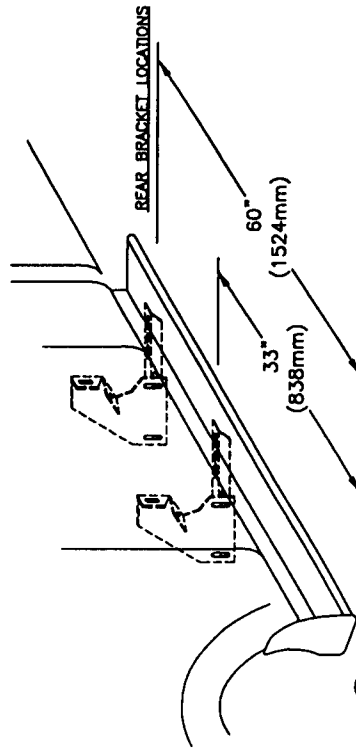

1 (DRIVERS SIDE SHOWN)
MEASURE FROM FRONT WHEEL WELL TO BRACKET LOCATIONS. MARK THIS DIMENSION ON THE PINCH WELD

2
BRACKET ASSEMBLY ASSEMBLE WITH 5/16" BOLTS

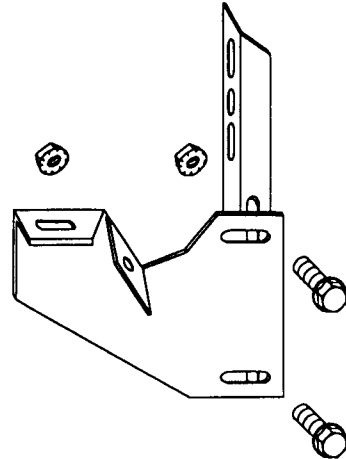

3
BRACKET ASSEMBLY MOUNT TO BODY DRILL THROUGH PINCH WELD WITH A 5/16" DRILL ASSEMBLE WITH 5/16" BOLTS AND #14 SELF DRILLING SCREW

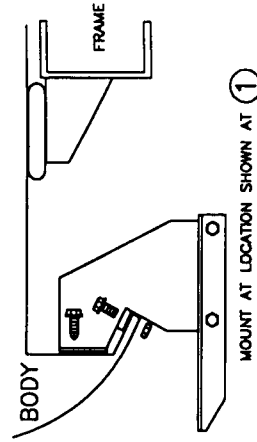

4
BEND STONE GUARD BY HAND AND KNEE TO FIT THE WHEEL WELL. BEFORE INSTALLING TO RUNNING BOARD



7
INSTALL END CAP TO BOARD WITH 3/8" SELF TAPPING BOLT

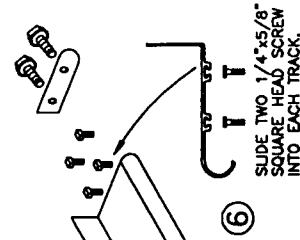

5
FASTEN FRONT STONE GUARD TO BOARDS WITH 3/8" SELF TAPPING BOLT. BEND STONE GUARD BY HAND AND KNEE TO FIT THE WHEEL WELL



6
SLIDE TWO 1/4"x5/8" SQUARE HEAD SCREW INTO EACH TRACK.

8
NOTE: BE SURE THAT 1/4" BOLTS ARE PLACED INTO THE BRACKET STEP SUPPORT

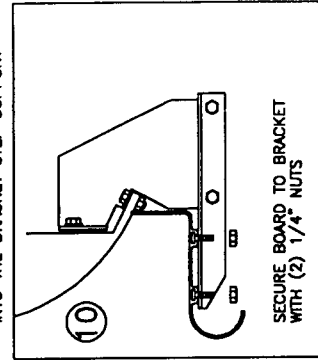

8
HOLD REAR IN PLACE, WITH THE REAR RESTING ON THE BACK BRACKET

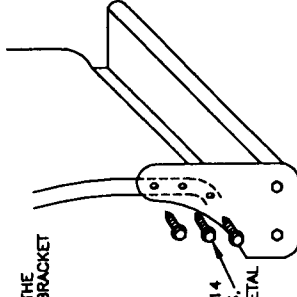

9
SCREW THROUGH STONE GUARD INTO FENDERWELL LIP USING #14 BY 3/4 SELF DRILLING SCREWS. MAKE SURE YOU DRILL INTO METAL

3 PLACES AT EACH STONE GUARD

11
WITH BOARD LEVEL TIGHTEN ALL LOOSE BOLTS

INZ61
08/30/04

12
REPEAT FOR OTHER SIDE