

**TOOLS REQUIRED:** 5/16" DRILL • 1/2" HEX SOCKET • 1/2" WRENCH • 5/16" NUT DRIVER • 3/8" NUT DRIVER  
**YOUR BRACKET MOUNT HOLES WILL NEED TO BE DRILLED INTO THE BODY**

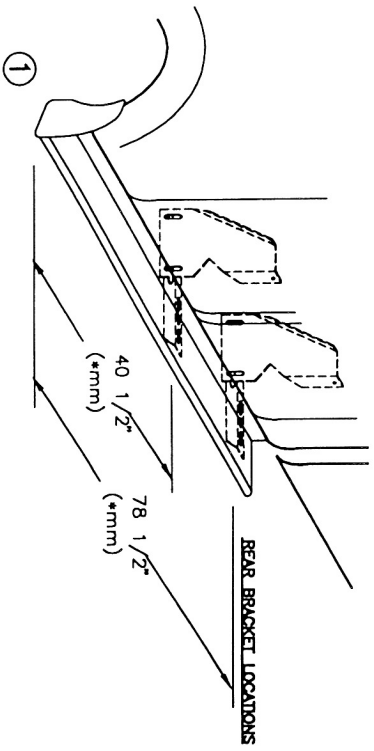

MEASURE FROM FRONT WHEEL WELL TO BRACKET LOCATIONS. MARK THIS DIMENSION ON THE PINCH WELD

(DRIVERS SIDE SHOWN)

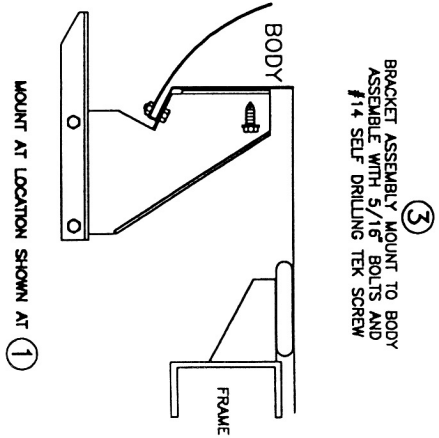
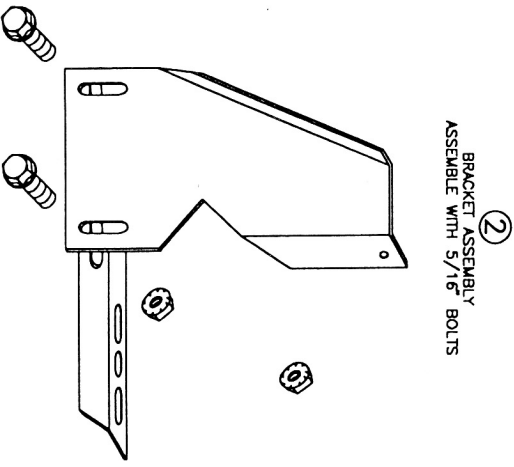

④ BEND STONE GUARD BY HAND AND KNEE TO FIT THE WHEEL WELL BEFORE INSTALLING TO RUNNING BOARD

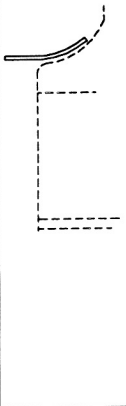

⑦ INSTALL END CAP TO BOARD WITH 3/8\"/>

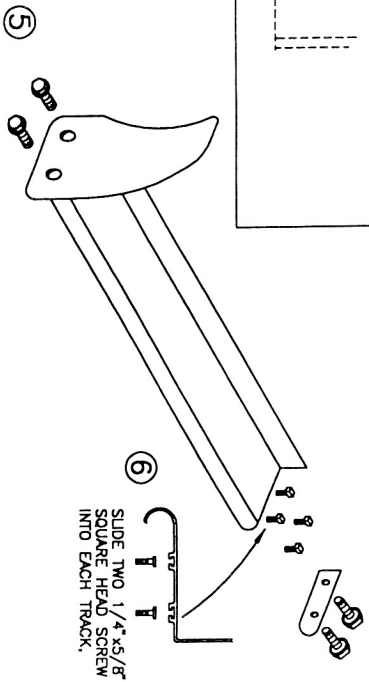

FASTEN FRONT STONE GUARD TO BOARDS WITH 3/8" SELF TAPPING BOLT. BEND STONE GUARD BY HAND AND KNEE TO FIT THE WHEEL WELL

⑦ HOLD BOARD IN PLACE, WITH THE REAR RESTING ON THE BACK BRACKET  
**NOTE:** BE SURE THAT 1/4" BOLTS ARE PLACED INTO THE BRACKET STEP SUPPORT

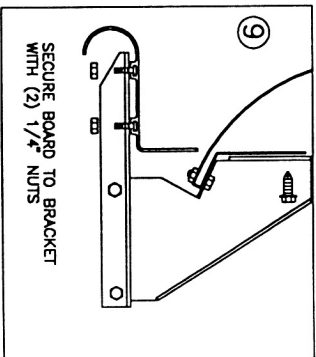
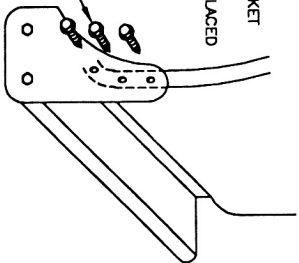

⑩ WITH BOARD LEVEL, TIGHTEN ALL LOOSE BOLTS

⑪ REPEAT FOR OTHER SIDE

**INSTALLATION PARTS LIST:**

QTY.	DESCRIPTION	QTY.	DESCRIPTION
1	RUNNING BOARD 1 DRIVER & 1 PASSENGER	1	END CAP 1 LEFT & 1 RIGHT
1	STONE GUARD 1 LEFT & 1 RIGHT	16	5/16" x 3/4" WASHER HEAD BOLT
8	3/8" x 1" SELF TAPPING SCREW	16	5/16-18 HEX WASHER HEAD NUT
10	#14 x 3/4" TEK SCREW	4	FLAT BRACKET, FLD7
8	1/4 x 5/8" SQUARE HEAD SCREW	4	HORIZONTAL BRACKET, SUPPORT, 3124F
8	1/4-20 HEX NUT		

IN34 05/15/02