



# **INSTALLATION INSTRUCTIONS**

**BLACK MODULAR GRILLE GUARD FOR FORD F150 (4WD) 99-04 / FORD  
F150 FLARESIDE (4WD) 99-04/ FORD EXPEDITION (4WD) 99-02**

**PART # 17FP26MA**



## Before Installation







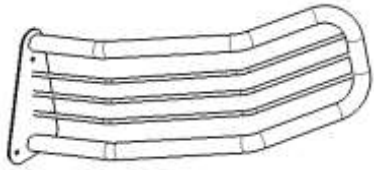
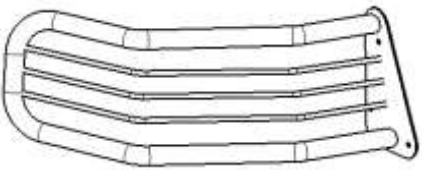

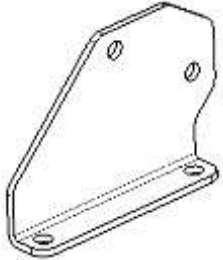

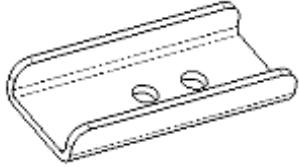
- Please read the instruction completely for easy installation, which will also help you to avoid scratches or other potential damages to your appealing car.
- The information shown here is for reference only and may differ from the product that you receive, however the goods are fitted in the same way.

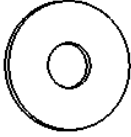

## Care and Cleaning

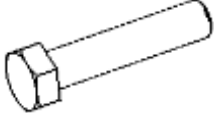
- Mild soap may be used also to clean the Product.
- Please periodically check and retighten all the hardware and clean the investment for a refresh look.

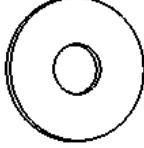
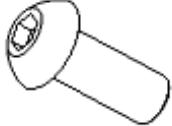
## Parts List

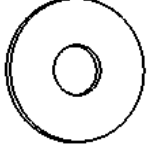
NO.	QTY	NAME	NO.	QTY	NAME
①	1	 Front Guard	②	1	 Left Brush Guard
③	1	 Right Brush Guard	④	1	 Left bracket
⑤	1	 Right bracket	⑥	1	 Connecting plate-1

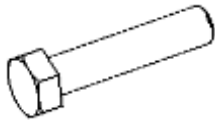
<p>⑦</p> <p>1</p>		<p>Connecting plate-2</p>	<p>⑧</p> <p>2</p>		<p>Connecting plate-3</p>
<p>⑨</p> <p>1</p>		<p>Connecting bracket A-L&amp;R</p>	<p>⑩</p> <p>1</p>		<p>Connecting bracket B-L</p>
<p>⑪</p> <p>1</p>		<p>Connecting bracket B-R</p>	<p>⑫</p> <p>10</p>		<p>Hex nut M10</p>
<p>⑬</p> <p>20</p>		<p>Flat washer D10</p>	<p>⑭</p> <p>10</p>		<p>Spring washer D10</p>
<p>⑮</p> <p>10</p>		<p>Hexagon bolt M10_30</p>	<p>⑯</p> <p>6</p>		<p>Hex Nut M8</p>
<p>⑰</p> <p>12</p>		<p>Flat washer D8</p>	<p>⑱</p> <p>6</p>		<p>Socket head cap screw 8_20</p>
<p>⑲</p> <p>2</p>		<p>Hex nut M12</p>	<p>⑳</p> <p>4</p>		<p>Flat washer D12</p>

<p>②1</p>	<p>2</p>	 <p>Spring washer D12</p>	<p>②2</p>	<p>2</p>	 <p>Hexagon bolt M12_110_30</p>
<p>②3</p>	<p>1</p>	 <p>Allen wrench S=5</p>	<p>②4</p>	<p>4</p>	 <p>Tapping screw ST9.5_25</p>

### Installation Steps

**Step One:** Locate hardware and check contents with the hardware listed below.

**Step Two:** Install left and right brush guard on the front guard as figure 1.

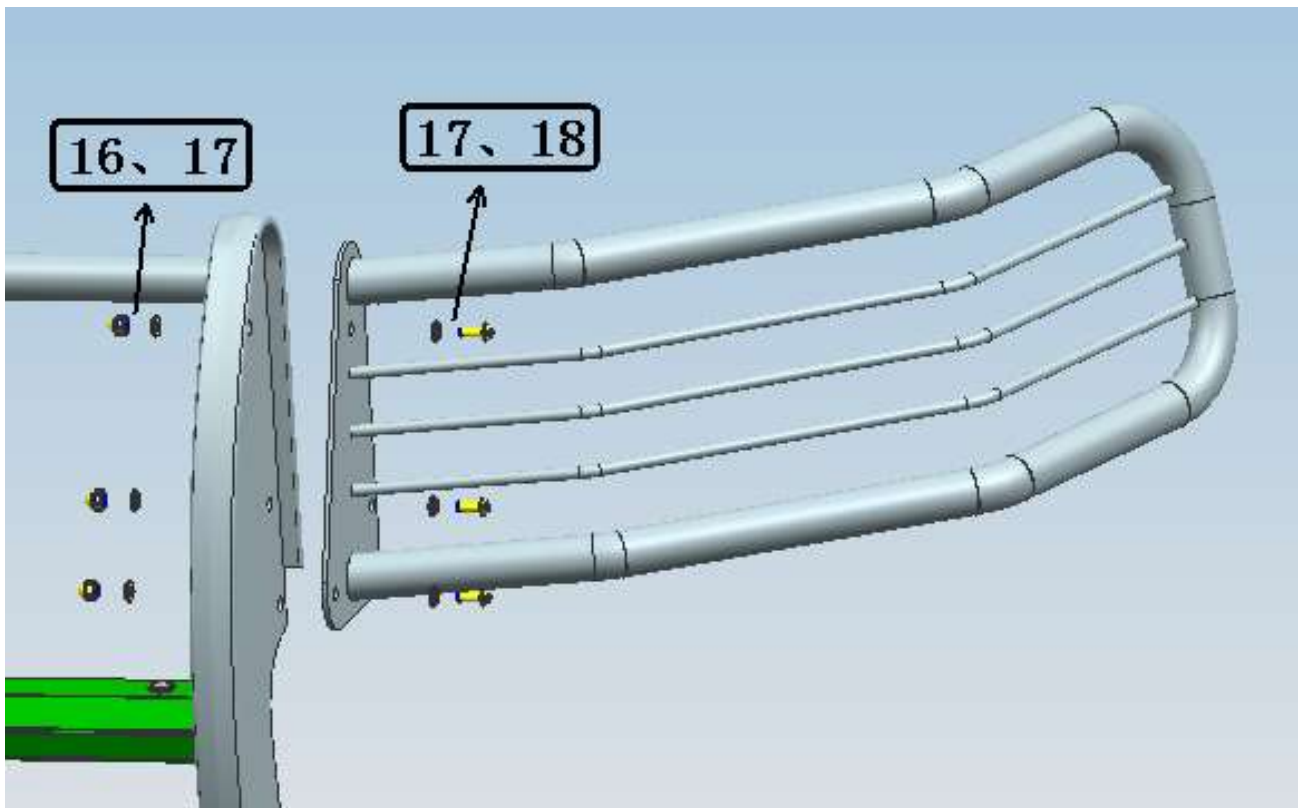

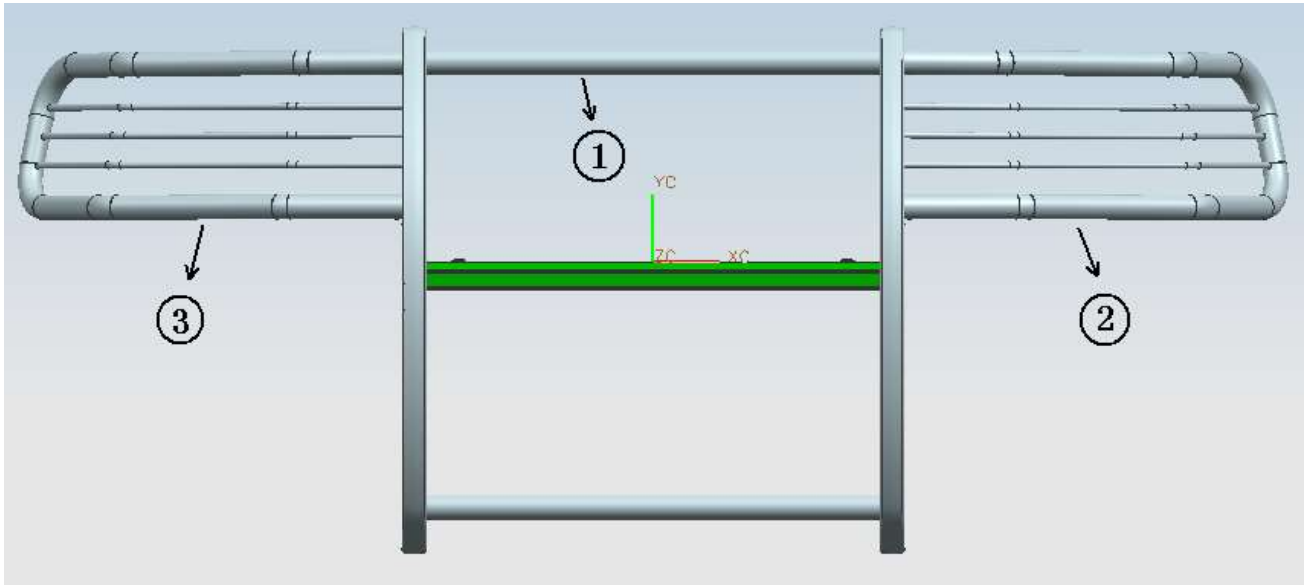

**Step Three:** Locate the lower support brackets left and right sides, two lower back-up brackets, two M12 hex bolts, two M10 lock washers, two M12 hex nuts and four M10 self-threading bolts. Position the lower support brackets and the lower back-up brackets up to the left frame rail as shown in fig #1, 2 and 3. Secure the two brackets to the frame with the M12 hardware listed in this step. Using the two remaining holes in the left lower support bracket as a guide, drill a 5/16 hole in the bottom of the frame. **“CAUTION” before drilling, be sure to check the backside of the drilling area for possible hazards or obstructions.** Using two M10 self-tapping bolts, secure the left lower support bracket to the bottom of the frame. Repeat this procedure using the right side lower support bracket and lower back-up brackets on the opposite side. **“Note”** there is lower support bracket right side for 2WD models that will be used instead of the normal right side lower support bracket.

(Brackets for reference only)



Fig #1



Fig #2

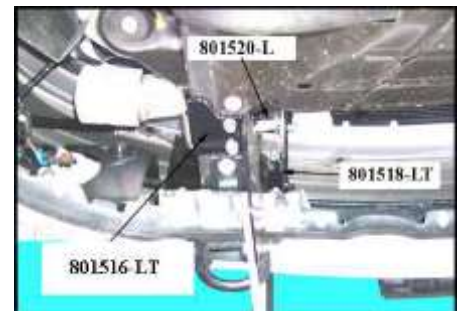

Fig #3

**Step Four:** Locate the left and right top back-up brackets. Remove the two bumper blade bolts. Place the left bracket in position and then secure the bracket to the frame with the factory hardware as shown in fig #3 & 4. Repeat this procedure using the right side bracket on the opposite side.

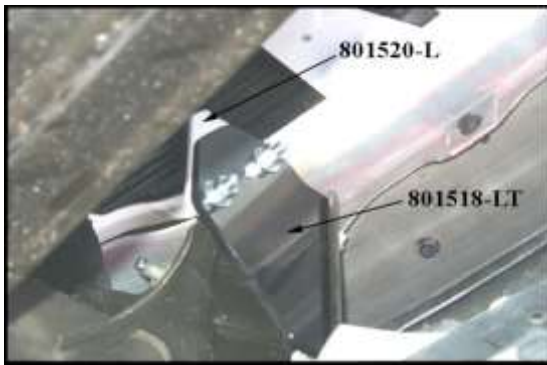

Fig #4



Fig #5

**Step Five:** Locate the left and right sides top support brackets, left and right side bracket gaskets, four M10 hex bolts, four M10 hex nuts, eight M10 flat washers and four M10 lock washers. Peel the paper backing off the gasket and attach the gasket to the bottom of the left top support bracket. Position the bracket on the vehicle as shown in fig #4 & 5. Using the hardware listed in this step, secure the bracket to the left top back-up bracket as shown in fig #4. Repeat this procedure using the right side top support bracket on the opposite side.

**Step Six:** Locate six M10 hex bolts, six M10 hex nuts, twelve M10 flat washers and six M10 lock washers. Position the guard to the outside of the top and lower support brackets. Using the hardware listed in this step, secure the guard to the support brackets. Be sure to fully tighten all hardware at this time.

## NOTE

Any damages and losses caused by improper installation and application, goes beyond our quality warranty.