



Strong As An Ox™

## BX3226 Installation Instructions 2000-02 Pontiac Sunfire

Serial No.

The headlight assembly, front fascia, horn bracket and windshield washer reservoir are removed for baseplate installation. Drilling is required. Trimming of air dam on metal bumper is required. The BX8869 is available for the vehicle. Attachment Tabs are 24 inches center to center and a height of 13 3/4 inches.



1. Remove the six push pins from black plastic cover on top side of fascia, lift cover and set aside.



2. Remove two metric bolts from headlight assembly with the 13MM socket, pull forward, unplug electrical and set aside, both sides.



3. Just behind headlight assembly are two metric bolts to remove with the 10MM socket and one lower metric bolt with the 11MM socket, both sides.



4. Forward of front tires are two metric bolts to remove with the 7MM socket, both sides.



5. Remove the three metric bolts just forward of the front tire, on the bottom side of fascia, using the 7MM socket, both sides. Pull fascia forward and set aside.

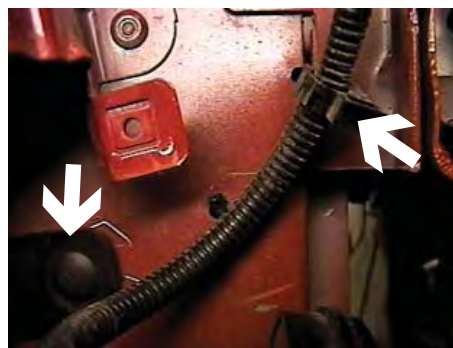

6. Remove christmas tree push pin and wire loom insert from passenger's side, just above horn bracket.



Strong As An Ox™

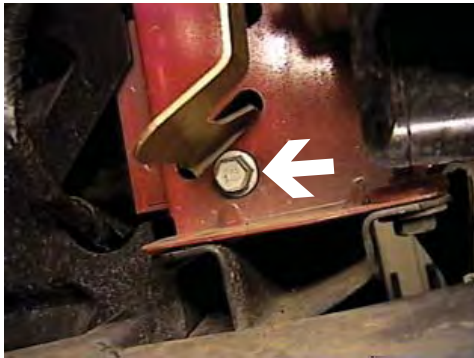

7. Using the 13MM socket, remove metric bolt from horn bracket and set aside.

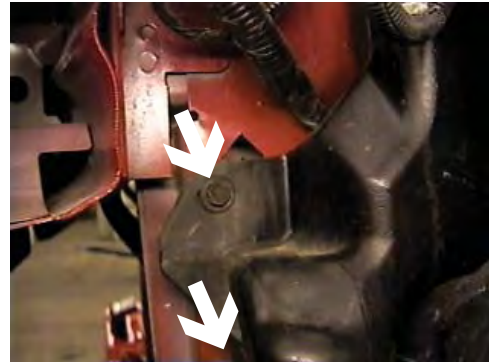

8. Remove two metric bolts from driver's side windshield washer reservoir using the 10MM socket.



9. Remove metric bolt from between wheel well and washer reservoir using the 10MM socket. Remove one phillips screw, pull reservoir down, unplug electrical connections, disconnect and plug water lines, set aside.



10. Notice black plastic that is attached on front of metal bumper. Using the metal bumper as a template, trim black plastic even with the bottom edge of metal bumper with the utility knife.

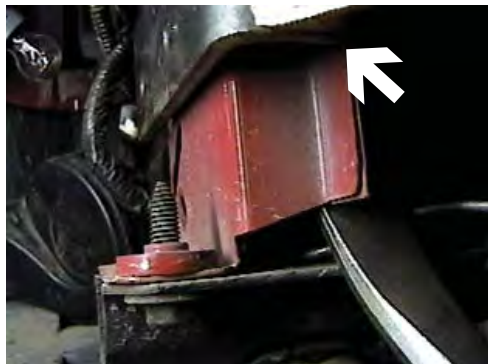

11. Secure baseplate to the bottom of metal bumper and opening of the front of bumper with clamps. Slide baseplate back to ribbing on front edge of frame, (notice clamp in photo of step 12).



12. Using the baseplate as a template drill two holes in the bottom side of the metal bumper with the 13/32" drill bit.



Strong As An Ox™



**13.** Insert nut plate into end of front bumper to align with drilled hole, tighten 3/8" bolt and lock washer, according to drawing on page 4, both sides. It may be necessary to enlarge opening with pry bar. **Be sure to use loctite on all bolts before tightening. Tighten all bolts according to Torque Chart in General Instruction Sheet.**



**14.** Using the baseplate as a template drill four remaining holes with the 13/32" drill bit, both sides.

**15.** Insert nut plates into opening of lower frame to align with drilled holes. Tighten 3/8" bolts and lock washers, according to drawing on page 4. It may be necessary to enlarge opening with pry bar. **Be sure and use loctite on all bolts before tightening. Torque all bolts according to torque chart in General Instructions.**

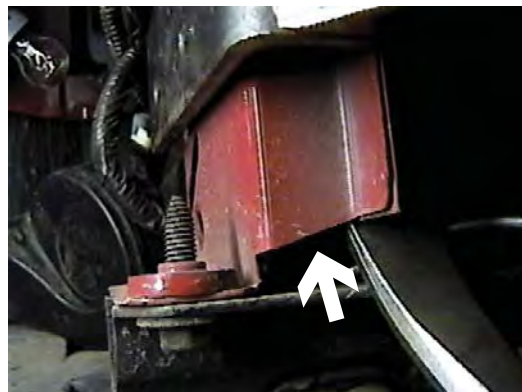

**16.** Reinstall horn bracket, windshield washer reservoir, fascia and headlight assemblies. Some models may require items 11 and 12 to reinstall washer reservoir. **Be sure all electrical components and hoses are plugged in properly.**

**17.** The dimensional variations between otherwise identical cars can be considerable. While the location and size of the holes in the baseplate were designed to allow for easy installation, it may be necessary to file a hole slightly to allow a bolt to clear.

**18.** Install the tow bar and safety cables according to the instructions included in their packages.

**19.** Do **not** substitute other devices if the tow bar pin and clip are lost.

**20. DEALER OR INSTALLER: BE CERTAIN THE USER RECEIVES THE INSTRUCTION SHEET.**



Strong As An Ox™

## Tools Required

7MM Socket  
13MM Socket  
Phillips Screw Driver  
Pry Bar

10MM Socket  
Loctite  
Vise Grips  
Utility Knife

11MM Socket  
13/32" Drill Bit  
9/16" Socket

## Parts List

Ref. No.	Qty.	Part No.	Description
1	1	61-5886	Weldment, Base Plate, BX3226
2	10	61-5208	3/8" Nut Plate, with Wire
3	10	201-0440	3/8-16 x 1 1/2 Bolt, Grd. 5, ZP
4	10	203-0010	3/8 Lock Washer, ZP
5	2	201-0553	1/4-20 x 1/2 Hx. Wshd, Type F Screw
6	2	202-0047	#10-32 Hex Nut
7	2	203-0054	#10 Lock Washer
8	2	201-0192	#10-32 x 1/2 Slot, Rd. Hd. Screw
9	2	101-5822	Adapter, 4 Way Connector
10	2	62-3469	Attachment, Assembly, SF/ LB (R)
11	2	201-0702	6MM-1 x 45MM, Hex Bolt, Grd 8.8, ZP
12	2	106-0366	Pipe, 1/4 Sch 40 x 3/4 Inch
	2	226-0046	Baseplate Safety Cable, 36" CL III (Not Shown)
	2	229-0359	Quicklink, 3/8, ZP (Not Shown)
	2	290-0437	Receiver, Cap Plug (BLK) (Not Shown)



*Location for the Bx8869 on driver's side tail light assembly.*

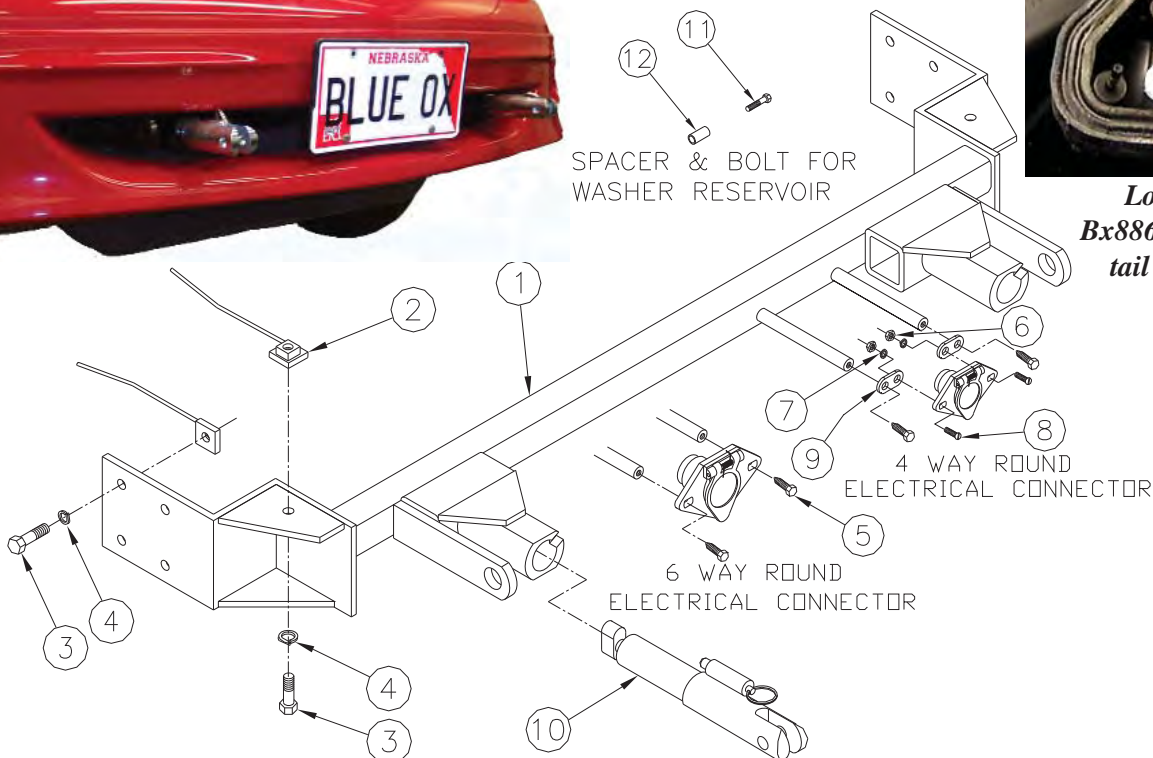

**IMPORTANT:** Use only genuine factory replacement parts on your Base Plate. Do not substitute homemade or nontypical parts. If a bolt is lost or in need of replacement, for your safety and the preservation of your Base Plate, be sure to use a replacement bolt of the same grade (Usually Grade 5, refer to parts list). Repair parts may be ordered through your nearest **Blue Ox** dealer or distributor.