



INSTALLATION INSTRUCTIONS DIRECT FIT TRANSMISSION COOLER PART # 20561

Please read these instructions completely before beginning installation

KIT CONTENTS

QTY.	DESCRIPTION	QTY.	DESCRIPTION
1	Cooler Assembly	12ft	RED Wire
1	Inner Frame J Bracket	1	5/16"-18 x 5" Bolt
1	Outer Frame C Bracket	1	5/16"-18 x 1 1/4" Bolt
2	-6 AN x 5/8-18 O-ring Fittings	1	5/16"-18 x 1" Bolt
1	Cooler Feed Hose	6	5/16" SAE Flat Washers
1	Cooler Return Hose Assembly	3	5/16"-18 Lock Nuts
4	Double Hose Support	3	1/4"-20 x 3/4" Bolts
1	Thermostat Switch	3	1/4" SAE Flat Washers
1	In-Line Thermostat Housing	3	1/4" Star Washers
12ft	Black Wire Loom	3	1/4"-20 Lock Nuts
2	Stainless Hose Clamps	4	Plastic Mounting Rods
4	Plastic Mounting Rods	4	Plastic Retainer Clips
8	1 x 1 Foam Pads	1	Blue Wire Splice Connector
1	Blue Wire Splice Connector	1	Blue Butt Connector
1	Blue Butt Connector	2	Blue Female Connector
2	Blue Female Connector	1	Blue Ring Terminal
1	Blue Ring Terminal	1	#10 Sheet Metal Screw
4	6" Zip Ties	4	6" Zip Ties
12	4" Zip Ties	12	4" Zip Ties

APPLICATIONS

**1987-1996
Jeep
Wrangler YJ**

**1997-2006
Jeep
Wrangler TJ**

IDENTIFYING COMPONENTS

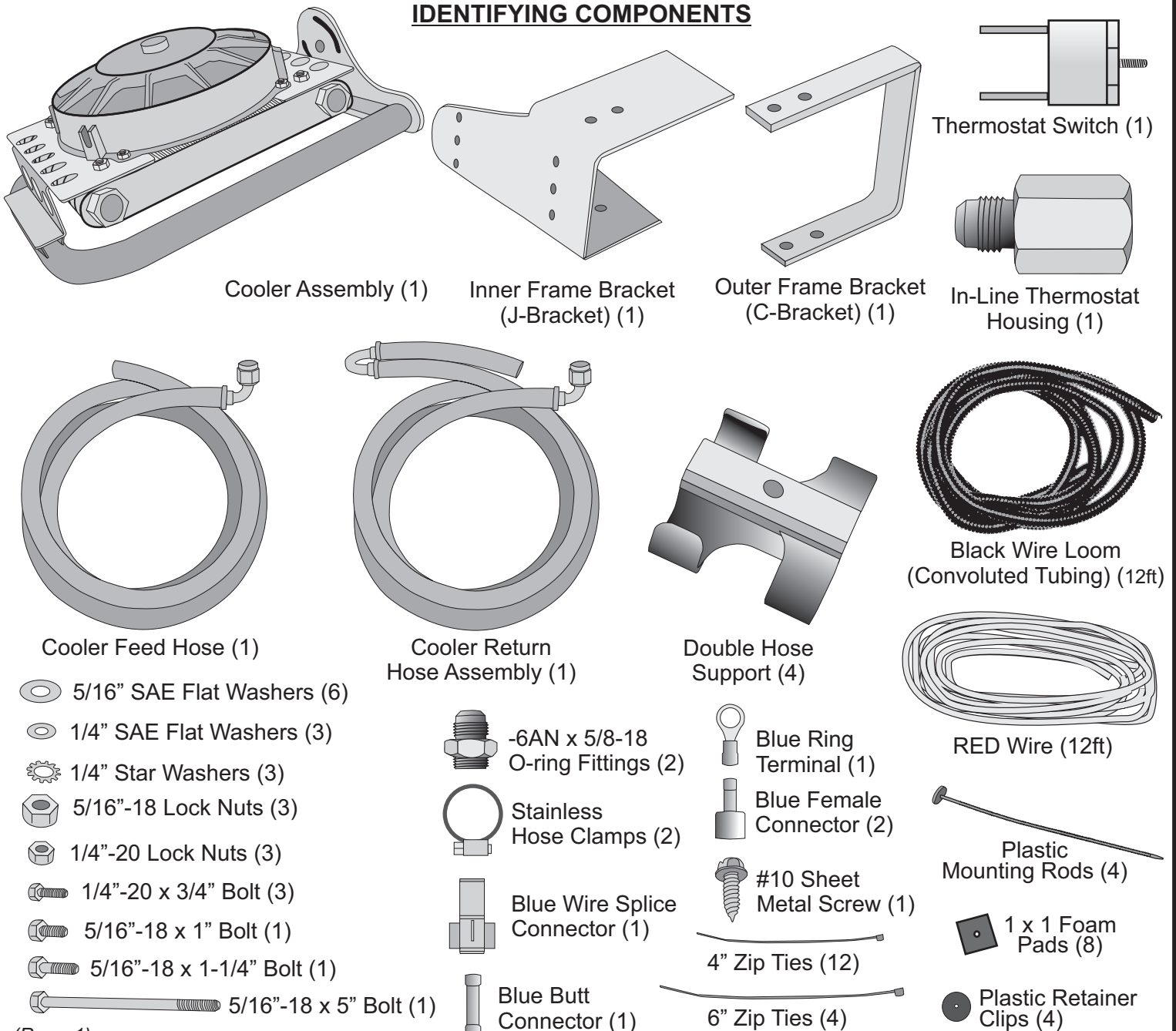

PRE-INSTALLATION

1. Using a flat table or workbench, lay the Cooler Assembly on a flat surface (Electric Fan facing up as shown in Section: Identifying Components).

THERMOSTAT INSTALLATION

1. Identify the two -6 AN x 5/8-18 O-ring Male Adapter fittings from the hardware kit.
2. Confirm that both O-rings are properly installed onto the 5/8-18 side of the fittings.
3. Using a lubricating oil, apply a small amount of oil to both O-rings.
4. Using a 1 1/16" line wrench, install and tighten the fittings onto the cooler, making sure you don't overtighten and cut the O-ring.
5. Identify the In-line Thermostat Housing and the Thermostat Switch.
6. Using Loctite or a suitable sealant, carefully screw the Thermostat Switch into the In-line Thermostat Housing turning the switch clockwise. (Hand Tighten Only) See Diagram #1

WARNING: DO NOT USE A WRENCH TO TIGHTEN THE THERMOSTAT SWITCH; OVERTIGHTENING WILL DAMAGE STUD AND VOID WARRANTY.

7. Identify the Inlet Port on the Cooler Assembly. When facing the ports on the cooler it will be on the right side. See Diagram #2
8. Take the In-line Thermostat Housing and Thermostat assembly and identify the female threads. Carefully screw the female side onto the Inlet Port of the Cooler Assembly. See Diagram #2
9. Using a 7/8" wrench and a 1-1/16" backup wrench tighten Thermostat Housing.

Diagram #1

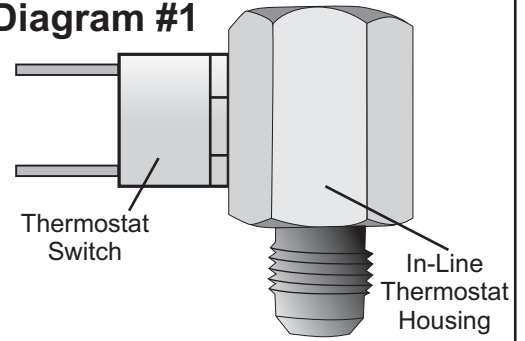
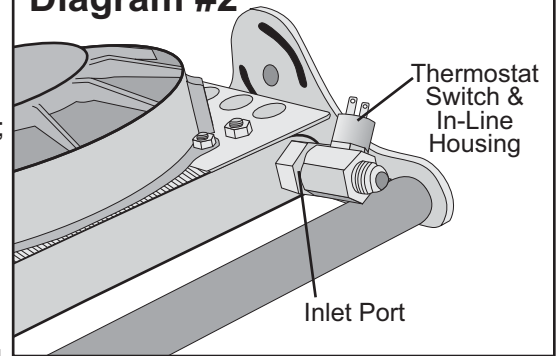

Diagram #2



PRE-INSTALLATION (Continued)

IDENTIFYING THE POSITIVE & NEGATIVE WIRES ON THE ELECTRIC FAN

1. Locate the Red/Silver label on the Electric Fan. See Diagram #3
2. This label identifies the airflow direction and the color of the Positive Fan wire. In this application the positive wire can be the black wire so make sure to check label.
3. Once you have determined the color of the positive and negative wires continue with the following steps, Pre-wiring the Cooler Assembly.

PRE-WIRING THE COOLER ASSEMBLY

1. Take the 12 feet of RED Wire and 12 feet of Black Split Wire Loom supplied.
2. Install the RED wire into the Black Wire Loom
3. Using a Blue Butt Connector supplied, attach one end of the Blue Butt Connector to either end of the RED wire using the proper crimping tool. See Diagram #4
4. Attach the Blue Female Connector to EITHER terminal on the Thermostat Switch. See Diagram #4
5. Using a Blue Butt Connector supplied, attach the Blue Female Connector to the Positive Wire on the Electric Fan. See Diagram #4
6. Attach the Blue Female Connector to the remaining Thermostat Switch wire. See Diagram #4

Diagram #3

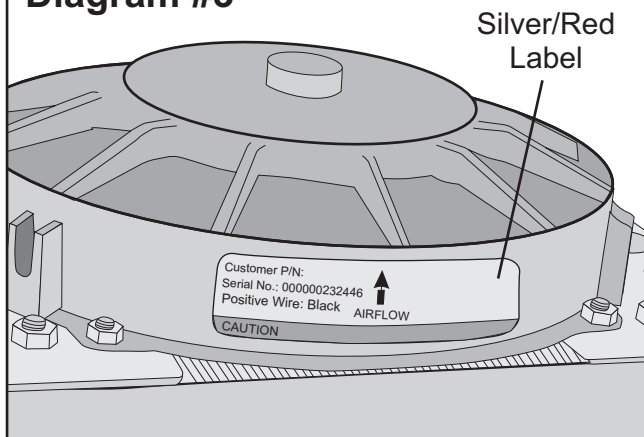
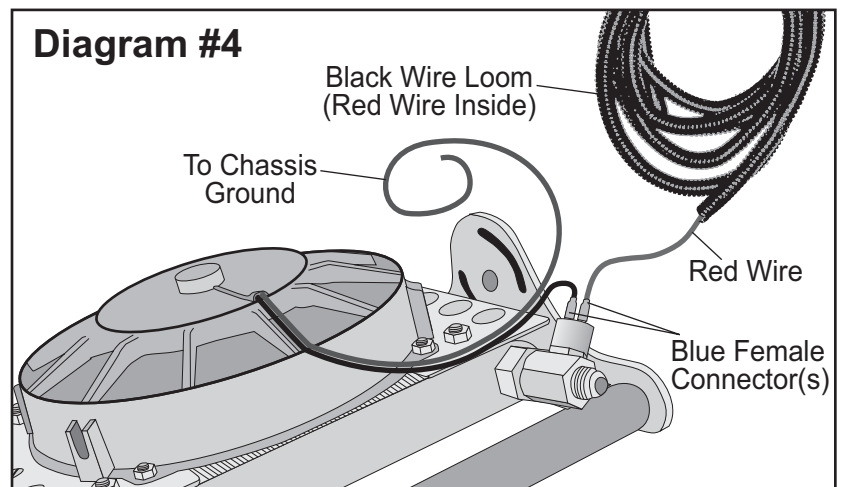

Diagram #4



VEHICLE INSTALLATION

COOLER LOCATION

The Cooler Assembly mounts on the drivers side frame between the rear trailing arm and the transmission/transaxle skid plate. See Diagram #5

VEHICLE PREP

1. Park vehicle on a solid, level surface and allow vehicle to completely cool before beginning installation.
2. Disconnect Positive lead on the vehicles battery.
3. With the transmission in park, engage the emergency brake. Carefully raise the vehicle using the appropriate floor jack/lifting device.
4. Properly place four jack stands, one for each corner of the vehicle. Refer to the vehicles owners manual for the proper lifting locations.

MOUNTING THE COOLER ASSEMBLY

1. Identify the Inner Frame J Bracket and the Outer Frame C Bracket.
2. Identify the following hardware, (1) 5/16-18 x 5" Bolt, (1) 5/16-18 x 1 1/4" Bolt, (1) 5/16-18 x 1" Bolt, (6) 5/16 SAE Flat Washers, (3) 5/16-18 Lock Nuts
3. Take the Inner Frame J Bracket. The longer leg sets on the top of the vehicles frame allowing the shorter leg to butt up against the side of the frame just below the vehicles fuel/brake lines. See Diagram #6
4. Take the Outer Frame C Bracket. This bracket slides from the outside of the vehicles frame over the top of the Inner Frame Bracket and around the vehicles frame. See Diagram #6
5. Using a 5/16" SAE Flat Washer, take the 5" bolt and install it into the bottom hole closest to the vehicles frame sliding it all the way up through the inside upper hole. Install a 5/16" SAE Flat washer and 5/16-18 Lock nut on the top of the bracket assembly and hand tighten. See Diagram #6
6. Using the 5/16-18 x 1" Bolt, SAE Washers, and 5/16-18 Lock Nut, install this bolt in the upper outside hole and hand tighten.
7. Using the 5/16-18 x 1 1/4" Bolt, SAE Washers and 5/16-18 Lock Nut install this bolt in the bottom outside remaining hole and hand tighten. See Diagram #6

NOTE: The frame brackets can be moved forward or back along the frame to assure clearance of the Cooler Assembly.

8. Identify the following hardware, (3) 1/4-20 x 3/4" Bolts, (3) 1/4" SAE Flat Washers, (3) 1/4" Star Washers, (3) 1/4-20 Lock Nuts
9. Take the Cooler Assembly and hold it up to the Inner Frame Bracket Assembly and install 1/4-20 Bolts, Flat Washers, Star Washers and Lock Nuts as shown in Diagram #7

IMPORTANT: Cooler Assembly has a built in pivot mounting system. This will allow you to pivot the cooler to not only clear all vehicles obstructions but to allow you to improve airflow on vehicles with extra body clearance. Always adjust Cooler Assembly with the maximum angle without touching any of the vehicles components.

10. Once Cooler Assembly is in the desired location, be sure to go back and tighten all mounting hardware.

NOTE: Outer Frame C Bracket is designed to bend up against the Inner Frame J Bracket causing a clamping effect.

Diagram #5

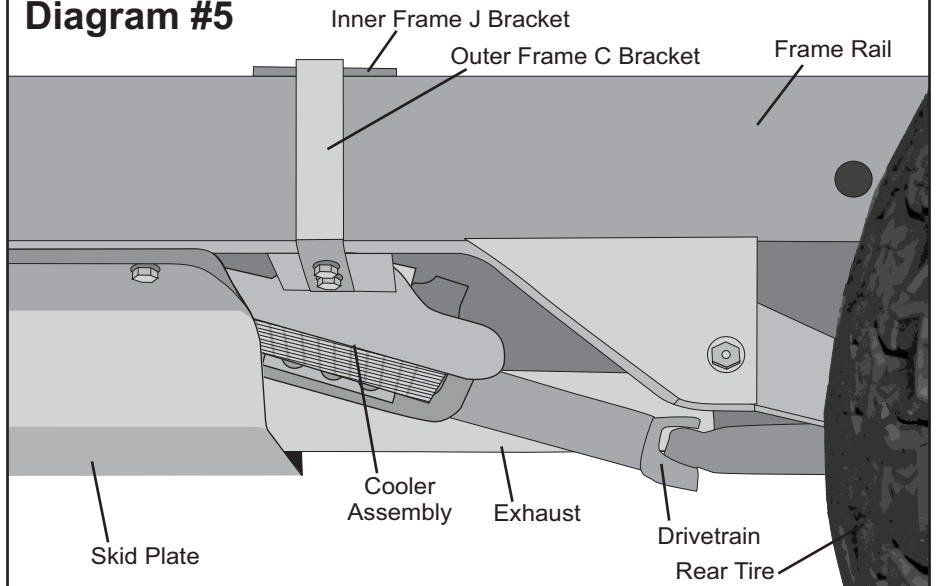

Diagram #6

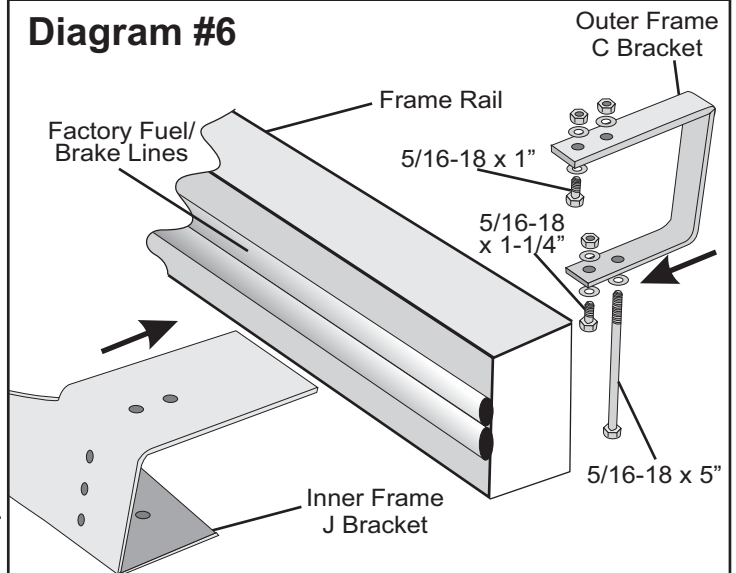
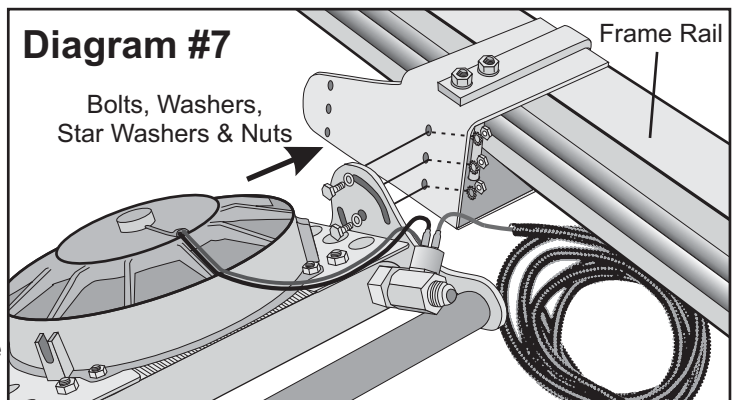
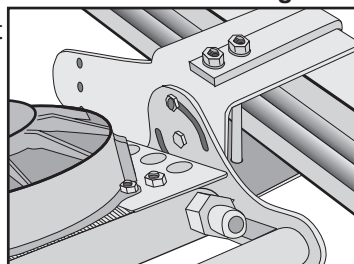

Diagram #7



Forward Mounting



Back Mounting

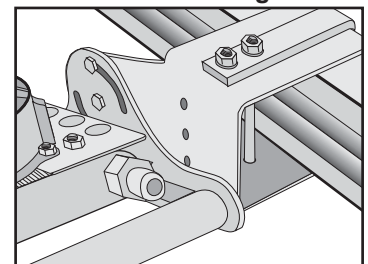

VEHICLE INSTALLATION (Continued)

COOLER HOSE INSTALLATION

1. Identify the Cooler Feed Hose and the Cooler Return Hose Assembly. Both hoses have one end with a 90 degree fitting.
2. Take the Cooler Feed Hose and install the 90 degree fitting onto the Inlet Port of the Cooler Assembly. See Diagram #8
3. Take the Cooler Return Hose and install the 90 degree fitting onto the Outlet Port of the Cooler Assembly. See Diagram #8
4. Route both hoses together and along the inner frame rail of the vehicle. See Diagram #8
5. Identify the following hardware, Plastic Mounting Rods, Plastic Retainer Clips, Double Hose Support, 1 x 1 Foam Pads and 6" Zip Ties.
6. Using Diagram #9 as a reference, Insert a 1 x 1 Foam Pad onto the Plastic Mounting Rod sliding the tip of the rod thru the factory Fuel/Brake lines.
7. Install another 1 x 1 Foam Pad, Double Hose Support and finally a Plastic Retainer Clip. See Diagram #9
8. Install the two hoses running along the frame into the Double Hose Support.
9. Cinch the Plastic Retainer Clip until completely tight slightly compressing the foam pads.
10. Cut excess mounting rods.
11. Use the 6" Zip Ties to secure hoses in areas making sure hoses are away from Hot or moving obstructions.
12. Repeat steps 5-10 along the frame rail up to the front of the vehicle.
13. Route hose up to the bottom of the vehicles radiator.
14. Disconnect the factory rubber transmission return hose from both ends and remove. One end-radiator fitting, Other end-Steel Transmission Line. See Diagram #10
15. Install a Hose Clamp supplied onto the Cooler Return Hose Assembly. Connect the short hose coming off the 180 degree fitting to the existing transmission line and tighten clamp. See Diagram #11
16. Install a Hose Clamp supplied onto the Cooler Feed Hose. Connect the hose onto the existing radiator fitting and tighten clamp. See Diagram #11
17. Route Cooler Feed Hose to the bottom of the engine fan shroud and install in plastic hose connector. See Diagram #11

Diagram #8

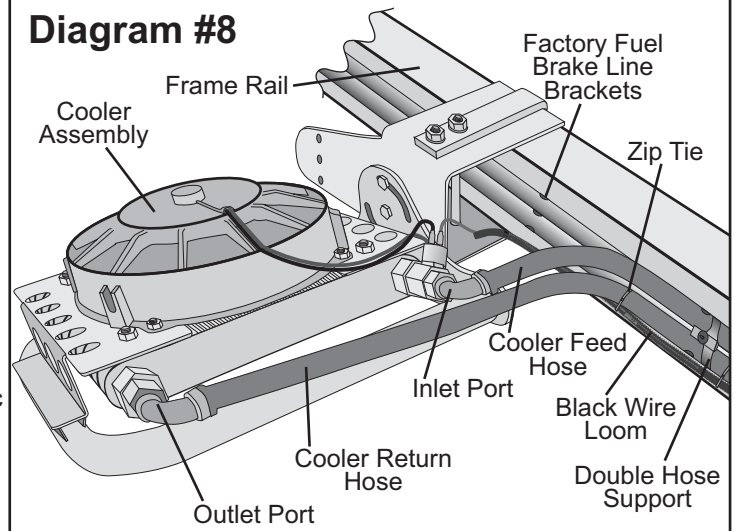

Diagram #9

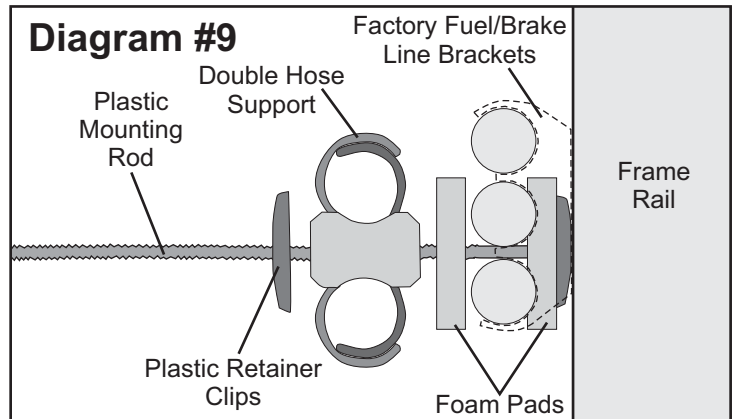

Diagram #10

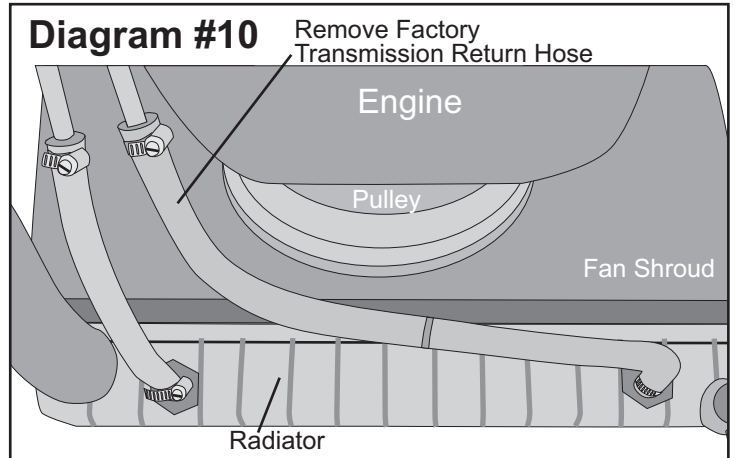
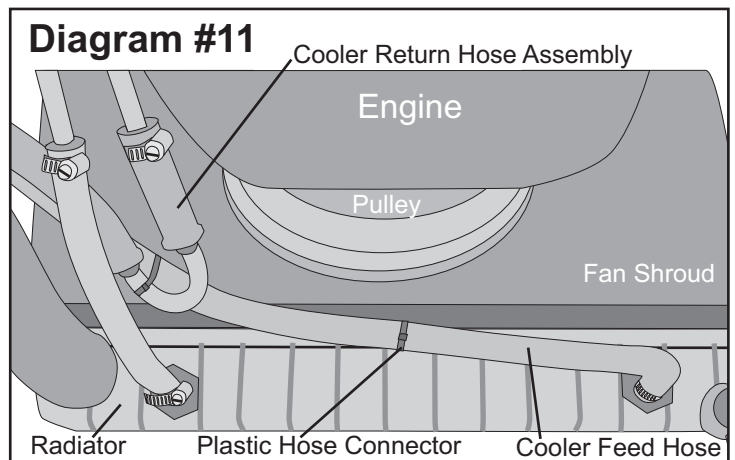

Diagram #11



VEHICLE INSTALLATION *(Continued)*

WIRING THE ELECTRIC FAN

1. Locate the negative wire on the electric fan. Look in the area of the Cooler Assembly along the vehicles frame or body and locate a good chassis ground.
2. Identify the Blue Ring Terminal Supplied.
3. Use the proper crimping tool; install the Blue Ring Terminal onto the Ground Wire of the electric fan.
4. Using the #10 Sheet Metal Screw supplied, install the negative wire.
5. Route the Black Wire Loom with the Red wire inside along the vehicles frame up to the vehicles firewall.
6. Using the 4" Zip Ties supplied attach the Black Wire Loom to the vehicles fuel line underneath the new transmission cooler hoses. See Diagram #12
7. The Red wire needs to be connected to the vehicles switched ignition source. An ignition source can be found in a few locations. 1. Under the dash 2. In the vehicles fuse box.
8. Using a test light identify a switched ignition source. Route Red wire to the ignition source.
9. Using the Blue Butt Connector and Blue Wire Splice Connector supplied, install Red wire onto the switched ignition wire, making sure this is a fused circuit. We recommend a 20 AMP Fuse (not supplied).

Note: Wiring fan directly to a 12V constant source will allow the fan to run after the vehicles ignition switch has been turned off. It is recommended to always use a switched ignition source.

AFTER INSTALLATION

1. Reconnect the positive battery cable
2. Carefully remove the jack stands and lower vehicle onto a flat surface.
3. Before starting vehicle, add 1 quart of fluid into the transmission.
4. With the parking brake applied, start vehicle and shift transmission several times from reverse to drive and then back to Park.
5. Check the transmission fluid level and add fluid as needed.

SYSTEM CHECK

1. Inspect all hose connections for leaks.
2. Drive vehicle 1-2 blocks and then recheck fluid levels.
3. Let vehicle completely warm up and then check to make sure electric fan turns on. Please note that it may take some time for cooler to warm up enough for electric fan to start. Driving vehicle several miles may be required.

Diagram #12

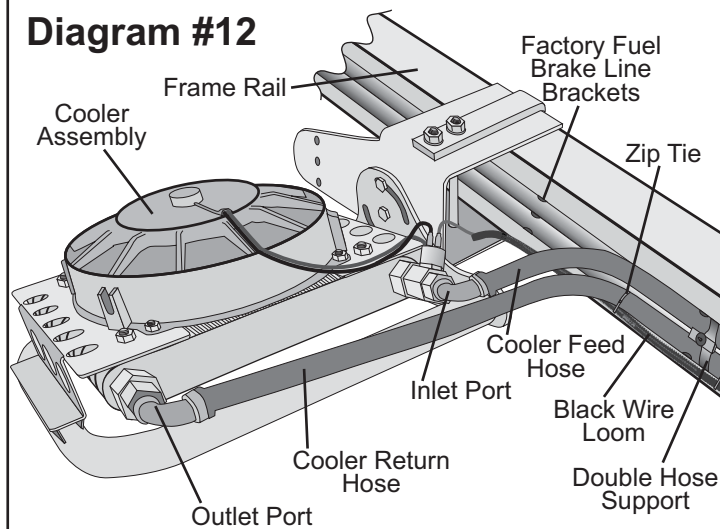

(Page 5)

Warning: Installation of accessories should only be undertaken by those with mechanical knowledge and are familiar with working on vehicles. Always use eye protection (goggles, safety glasses or shield). Park the vehicle in a well lit area, on level ground and apply the parking brake. Only work on a cold vehicle that has been sitting overnight, failure to do so will result in severe burns and injury. Before starting the vehicle, make sure no tools or any other items are left under hood that could interfere with or be drawn into moving parts of the engine. Failure to follow instructions can lead to severe damage and personal injury.