



DINAN

**HI-CLAMP LOAD CLUTCH ASSEMBLY
INSTALLATION INSTRUCTIONS**

PART NUMBER D550-0015A

APPLICATION: E39 540i/M5, E52 Z8 (with stock or
Dinan Stage 1 Lightweight Flywheel)
E46 M3

PARTS LIST

<u>Qty</u>	<u>Part No.</u>	<u>Description</u>
1	D553-0019	Pressure Plate
1	D553-0016	Clutch Disc

Congratulations for being selective enough to use a Dinan Engineering Hi-Clamp Load Clutch. We have spent many hours developing this clutch to assure that you will receive maximum performance and durability with minimum difficulty in installation. Please take the time to read these instructions and call us if you have any difficulties during the installation.

CLUTCH INSTALLATION NOTES:

- Please review the factory procedure prior to starting work. Additional components may be needed to complete this installation.
- E39 & E52 ONLY: For best performance, Dinan highly recommends use of this clutch kit with our Stage 1 Lightweight Flywheel.

- E39 & E52 ONLY: The flywheel hub area will need to be machined to provide adequate clearance for this clutch. See diagram below:

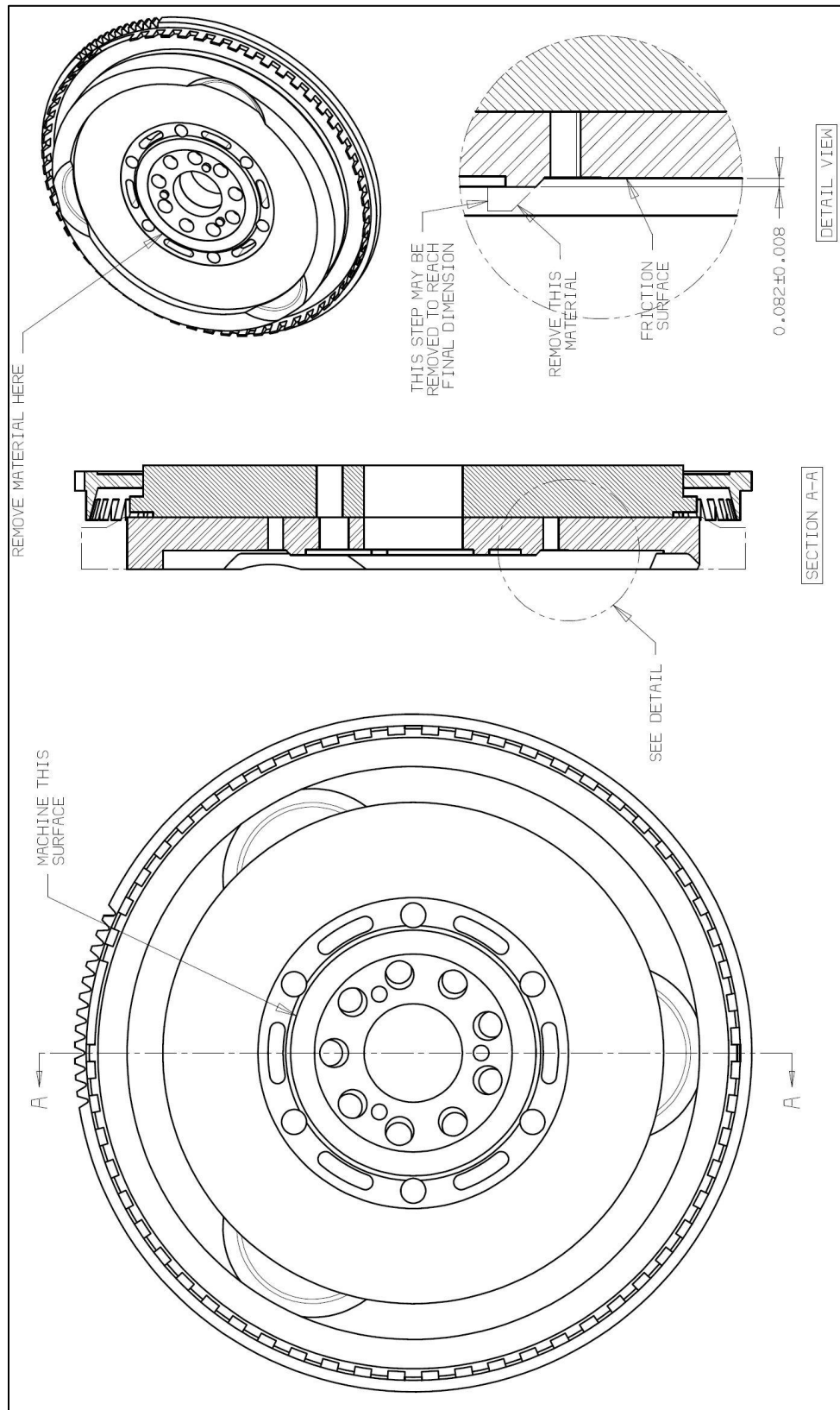

- E39 Dinan Stage 1 Lightweight Flywheels purchased after October 2011 do not require this modification.
- E46 M3 flywheels do not require flywheel modification.
- You must use the factory tools and follow the TIS for installation of the flywheel and pressure plate!
- The pressure plate cover bolts are one-time use. Torque requirements:
 - Initial torque to 11 ft-lbs,
 - Then angle torque an additional 90°.
- Dinan always recommends the installation of a new pilot bearing when installing a new clutch assembly.

If you encounter any difficulties during the installation, or if these instructions are not clear to you, please call Dinan's Technical Support Staff at (408) 779-8584.