

12. Aim your SS3 pods on each side, so that the top of the beam pattern is on the cutoff line mark.

13. Tighten the 5/32" allen bolts back down to complete the installation. Do not overtighten or use power tools to torque them down.

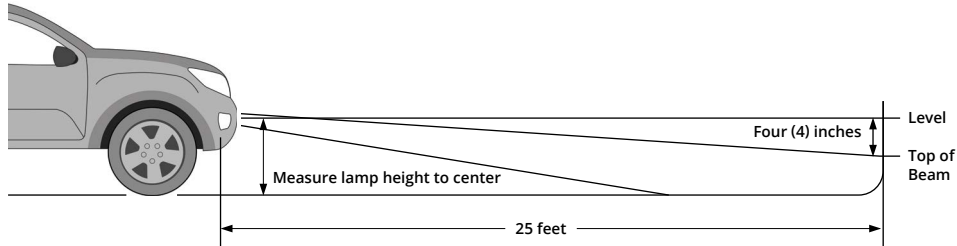

Please contact **Diode Dynamics** should you have any questions about the installation or wiring process, at **314-205-3033** (10a-5p CST) or contact@diodedynamics.com.

NEED MORE HELP?

Scan the QR code to link to our YouTube Channel!

We continuously bring in vehicles to our testing garage in order to create step-by-step videos to walk you through the installation process on your specific vehicle. Scan the QR code to see all our installation videos. Be sure to subscribe to our channel to stay up-to-date on the newest products and videos from Diode Dynamics!



This installation guide is for the following SKUs:

SS3 Sport Type B Kit White SAE Driving (**DD6184** W/O BL, **DD6995** ABL)
 SS3 Sport Type B Kit White SAE Fog (**DD6185** W/O BL, **DD6996** ABL)
 SS3 Sport Type B Kit Yellow SAE Fog (**DD6187** W/O BL, **DD6997** ABL)
 SS3 Pro Type B Kit White SAE Driving (**DD6188** W/O BL, **DD6998** ABL)

SS3 Pro Type B Kit White SAE Fog (**DD6189** W/O BL, **DD6999** ABL)
 SS3 Pro Type B Kit Yellow SAE Fog (**DD6191** W/O BL, **DD7000** ABL)
 SS3 Max Type B Kit White SAE Fog (**DD6686** W/O BL, **DD7001** ABL)
 SS3 Max Type B Kit Yellow SAE Fog (**DD6687** W/O BL, **DD7002** ABL)

100% SATISFACTION
GUARANTEE



Thank you for your purchase of our new SS3 Type B Foglight Kit. CAD-designed to use existing mounting points, this kit is compatible with the Toyota Tundra, Tacoma, 4Runner, Corolla, and more. Basic installation instructions are included below.

Please contact us if you have any questions.

COMPUTER DESIGNED
OEM FITMENT

ASSEMBLED IN
USA

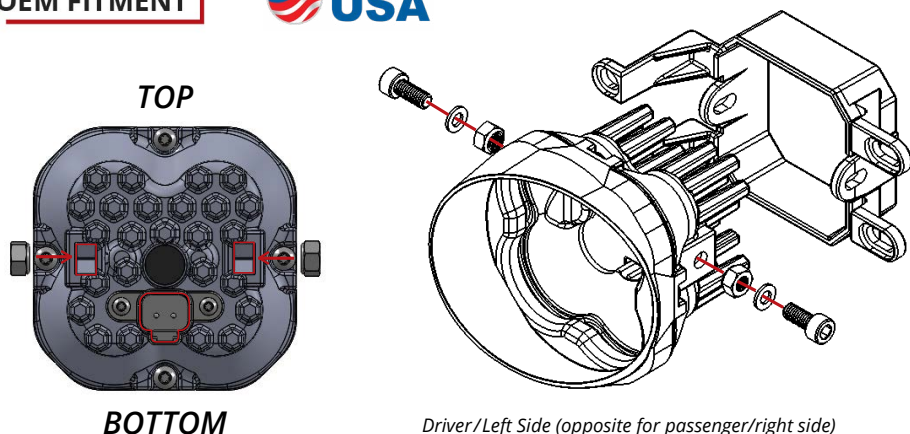

1. Install the supplied nuts into the pod housing with the nylon facing inward. Attach the bracket to the pod using the supplied screws and washers. Make sure the bracket is in the correct orientation, and the lamp angle matches the bracket. The side of the vehicle is indicated on the back of the bracket. See diagrams above. Ensure that the screws are tightened such that the pod retains its position, but can pivot with force for aiming.

2. Access your factory fog lights, by reaching down near the headlight or by removing fender liner.

3. Disconnect the fog light connector from the vehicle wiring harness. Remove the factory fog light housing. The factory hardware will be reused.

4. Install your new SS3 pod using the factory hardware. The tabs and holes on the bracket should align with the mounting points of the factory fog light housing. Re-use the factory hardware, tightening securely.

5. Use the included wire adapters to connect the pod to the vehicle wiring harness. Test function. If the light does not turn on, try flipping the connector 180°.

If you purchased backlit SS3 pods, connect the backlight power wire to a fused 12V source to trigger the backlight feature (i.e. parking light or sidemarker); T-Taps are included for this purpose. Check local laws and regulations for on-road use of backlight feature.

NOTE: Power source must be fused. Do not connect directly to vehicle battery.

6. Repeat the steps on the other side of the vehicle.

Aiming Instructions



7. Park your vehicle 25 feet away from a wall or garage door on a level surface.



8. Loosen the 5/32" allen bolts on each side of your SS3 pod, just enough to allow you to adjust the pod.



9. On your vehicle, measure the distance between the ground and the center of your SS3 pod. This is your mounting height.

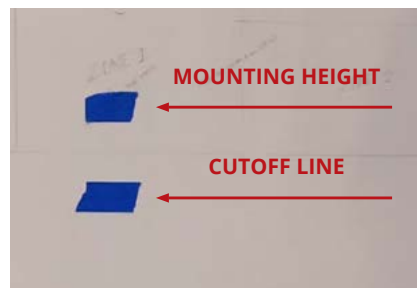

10. Mark the mounting height on the wall or garage door using tape.

11. Add another piece of tape four inches below the mounting height. This is your fog light cutoff line.

See back for further instructions.