

PART #P000006



**Front Bumper for 12-15 Toyota Tacoma
(Included winch plate, 20" single row LED light bar)**

PARTS LIST:

1	CS-1 HD Winch Front Bumper	2	10-1.5mm x 30mm Button Head Bolts
1	Winch Tray/Bracket Assembly	2	10mm x 20mm x 2mm Flat Washers
1	Driver/left Mesh Fill Panel	2	10mm Nylon Lock Nuts
1	Passenger/right Mesh Fill Panel	2	8-1.25mm x 25mm Hex Bolts
1	Driver/left "L" Top Light Bracket	2	8-1.25mm x 16mm Hex Bolts
1	Passenger/right "L" Top Light Bracket	6	8mm x 24mm x 2mm Flat Washers
2	Plastic Plugs for License Plate	4	8mm Lock Washers
1	Pivoting License Plate Bracket	2	8mm Hex Nuts
2	12-1.75mm x 120mm Hex Bolts	8	6mm x 20mm Button Head Combo Bolts
6	12-1.75mm x 45mm Hex Bolts	1	6mm Wrench
2	12mm x 44mm x 4mm Large Washers	1	5mm Wrench
2	12mm x 32mm x 3mm Flat Washers	1	4mm Wrench
6	12mm x 24mm x 2mm Small Flat Washers	1	2000mm Edge Trim
6	12mm Lock Washers	10	Nylon Wire Ties
2	12mm Nylon Lock Nuts		

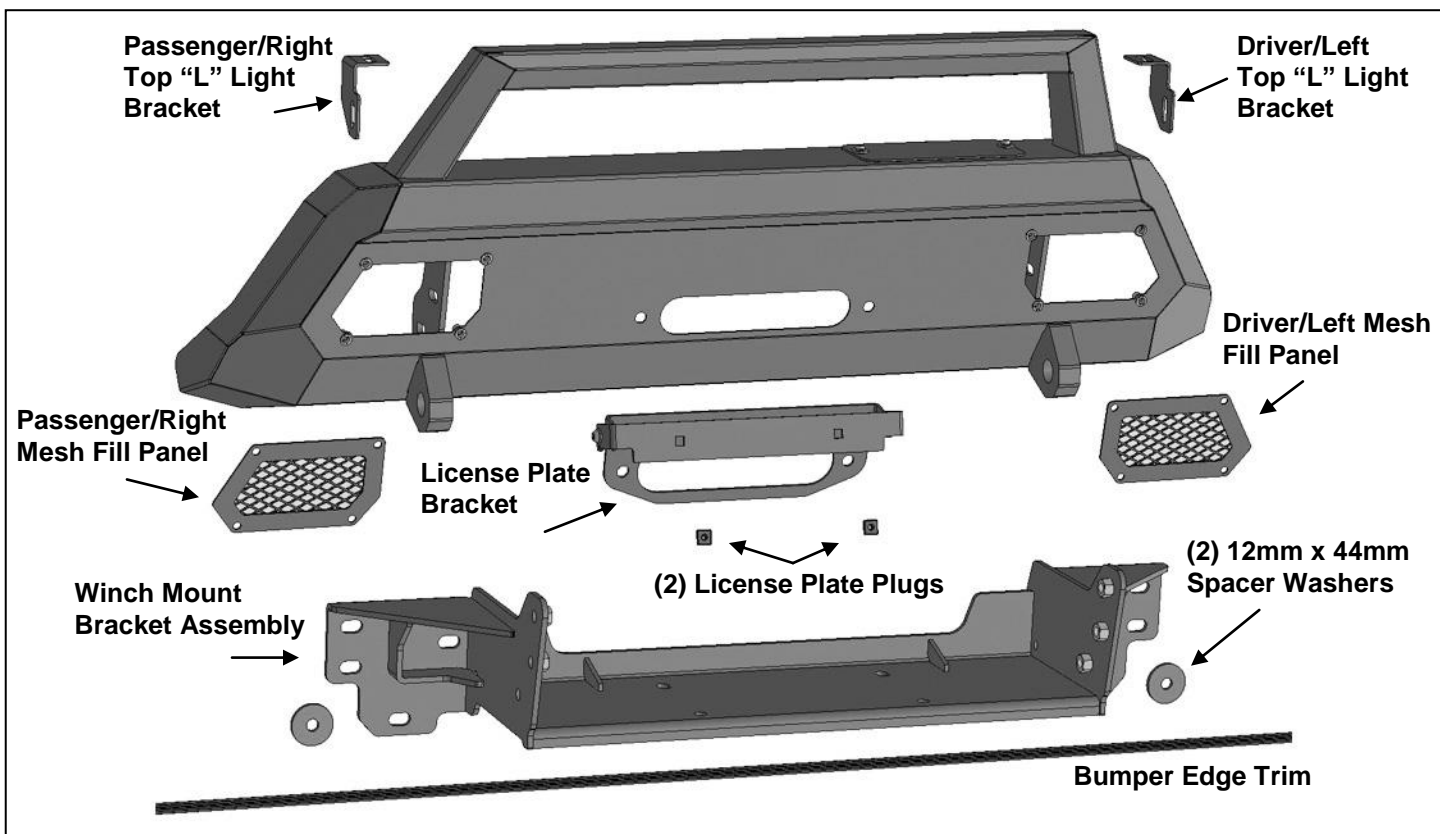

PROCEDURE:

REMOVE CONTENTS FROM BOX. VERIFY ALL PARTS ARE PRESENT. READ INSTRUCTIONS CAREFULLY BEFORE STARTING INSTALLATION. ASSISTANCE IS HIGHLY RECOMMENDED TO AVOID POSSIBLE INJURY OR DAMAGE TO THE VEHICLE. CUTTING IS REQUIRED.

1. Remove the license plate and bracket from the bumper cover.

2. Move to the passenger/right wheel opening. Remove the hardware attaching the plastic bumper cover to the bottom of the front fender and inner fender liner, **(Figures 1 & 2)**. On models with factory fog lights, unplug both lights and release the wiring harnesses from the clips attached to the back of the bumper and move wiring harnesses away from the bumper. Continue to remove the hardware attaching the bottom and driver/left end of the bumper cover.
3. Open the hood and remove the cover from the top of the grille. Next, remove the grille, **(Figure 3)**.
4. Remove the hardware attaching the top of the bumper and with assistance, remove the bumper cover, **(Figure 4)**. **NOTE:** Depending on model year, it may be necessary to temporarily remove the plastic fill panels below the head lights to access cover hardware, **(Figure 3)**. Move cover to a clean surface.
5. Remove the aluminum impact bumper and brackets from the end of the frame, **(Figures 4 & 5)**.
6. Follow the instructions packaged with the winch to attach the winch to the top of the winch tray on the Bracket assembly. **NOTE:** Winch not included, installation is optional.
7. With assistance, hold the Bracket assembly and winch up to the end of the frame. Reuse the factory hex nuts to attach the Bracket assembly to the frame, **(Figure 6)**. Do not fully tighten hardware.
8. Insert (1) 12mm x 120mm Hex Bolt with (1) 12mm x 32mm STD Flat Washer into the front of the Frame Bracket and crossmember, **(Figure 7)**. Guide the long Hex Bolt through the crossmember. Secure the Bracket to the long Hex Bolt with (1) 12mm x 44mm Spacer Washer and (1) 12mm Nylon Lock Nut, **(Figures 7 & 8)**. Snug but do not fully tighten Bumper Bracket hardware at this time. Repeat this **Step** to attach the passenger/right side of the Frame Bracket assembly.
9. Move to the factory plastic bumper cover. Remove the decorative cover from the center of the bumper cover, **(Figures 9 & 10)**. Use a sharp knife or hacksaw blade to cut along the indented trim line in the Bumper, **(Figure 11—13)**. **IMPORTANT:** Leave an approximate 1/2" edge to apply the included push on Edge Trim.
10. Reinstall the plastic bumper cover after cutting , **(Figure 14)**.
11. Align and center the Frame Bracket and Winch assembly and fully tighten all attaching hardware.
12. Hold the Winch Bumper up in position to the inside of the Frame Brackets. Check the fit between the cut bumper cover and the Winch Bumper, trim plastic as necessary and temporarily remove the Winch Bumper. Clean up any rough edges along the cut and apply the Edge Trim to the plastic bumper cover, **(Figure 14)**.
13. Attach winch cable guide or roller, (not included), to Bumper at this time. If front license plate is required, attach the pivot License Plate Bracket to the front of the Bumper and guide/roller with the included (2) 10mm x 30mm Button Head Bolts, (2) 10mm Flat Washers and (2) 10mm Nylon Lock Nuts, **(Figure 15)**. Remove Cover from the top of the Bumper to access release lever on winch, **(Figure 16)**.
14. With assistance, position the Bumper Assembly up to the outside of the Bracket Assembly. Temporarily support the weight of the Bumper. **WARNING:** To avoid possible injury or damage to the vehicle, do not proceed until the Bumper is fully and safely supported.
15. Line up the driver/left side mounting plate on the back of the Bumper with the Bracket Assembly. Attach the Bumper to the Bracket with the included (3) 12mm x 45mm Hex Bolts, (3) 12mm Lock Washers and (3) 12mm x 24mm Small Flat Washers, **(Figures 17 & 18)**. Do not fully tighten hardware at this time. Repeat this **Step** to attach the passenger/right side of Bumper.
16. Level and adjust the bumper and fully tighten all hardware.
17. Determine if accessory light, (not included), will be installed on the Bumper Hoop.
 - a. Select the driver/left Top Light Bracket. Attach the Bracket to the slot on the back of the Bumper Hoop with (1) 8mm x 25mm Hex Bolt, (2) 8mm x 24mm Flat Washers, (1) 8mm Lock Washer and (1) 8mm Hex Nut, **(Figure 19)**. Do not tighten hardware at this time.
 - b. Repeat previous Step to attach the passenger/right Bracket.
 - c. Select the 20" light, (not included). Attach the light to the Top Light Brackets with the hardware included with the light or the supplied (2) 8mm x 16mm Hex Bolts, (2) 8mm Lock Washers and (2) 8mm x 24mm Flat Washers, **(Figure 19)**. Adjust and fully tighten light and Bracket hardware.
18. Attach the Mesh Fill Panels to the Bumper with the included (8) 6mm Combo Bolts, **(Figure 20)**.
19. Use the included (2) push-in Plastic Plugs to attach the front license plate, (if required), to the (2) holes in the License Plate Bracket, **(Figure 20)**.
20. Do periodic inspections to the installation to make sure that all hardware is secure and tight.

To protect your investment, Do not use any type of polish or wax that may contain abrasives that could damage the finish. Mild soap may be used to clean the Front Bumper assembly.

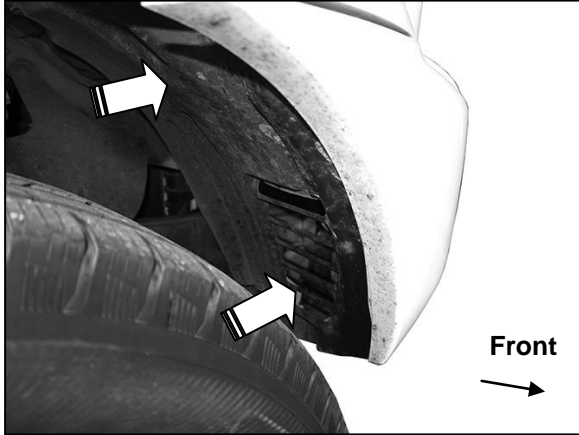

(Fig 1) Remove hardware attaching ends of bumper cover

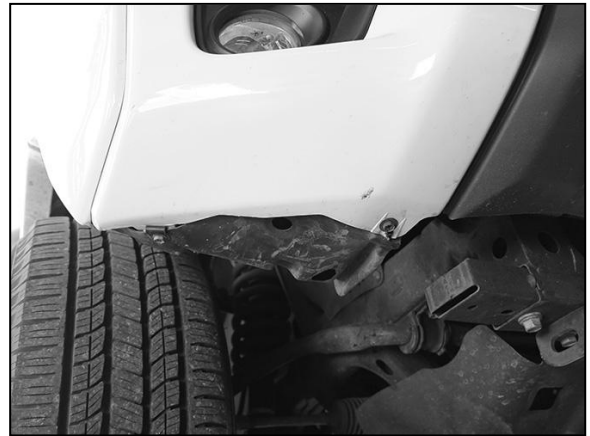

(Fig 2) Remove hardware attaching bottom of bumper cover



(Fig 3) Remove cover and grille. Remove hardware attaching top of bumper cover to remove cover

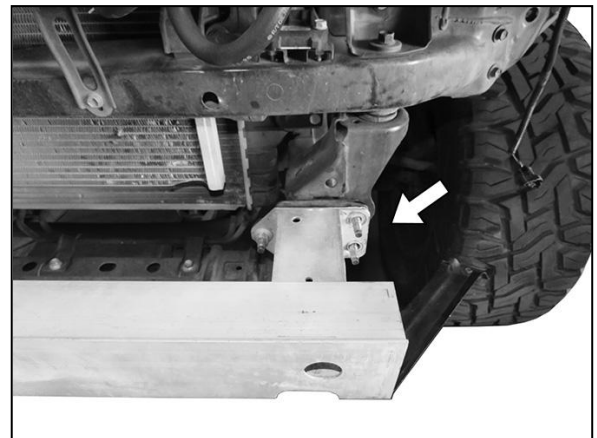

(Fig 4) Remove the aluminum impact bumper and brackets (arrow)

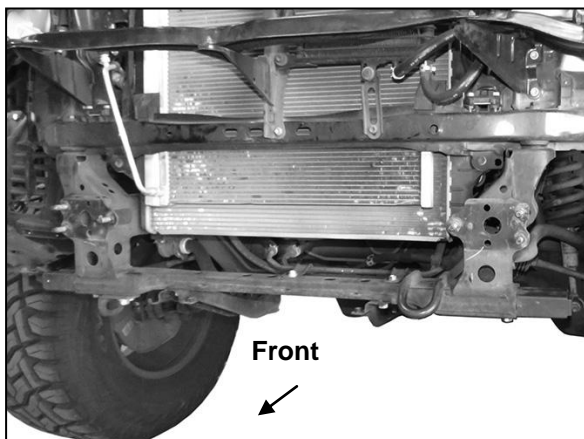

(Fig 5) Bumper removed

Driver/left Side Installation Pictured

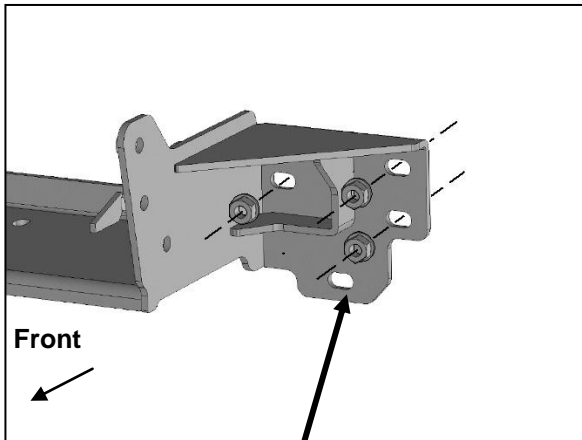

(Fig 6) Reuse the (6) factory hex nuts to attach Winch Tray/Bracket assembly to the end of the frame (driver/left side illustrated)

12mm x 44mm Spacer Washer
12mm Nylon Lock Nut

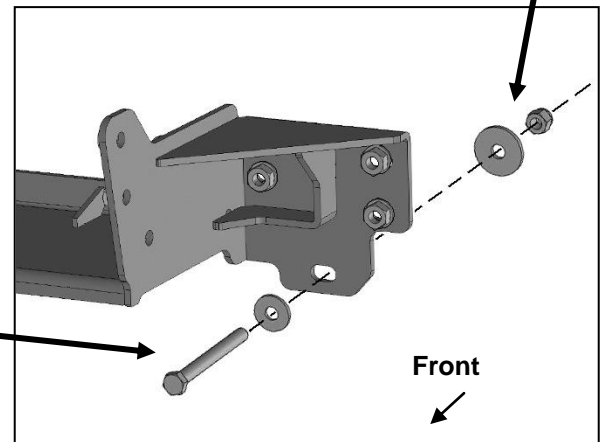

(Fig 7) Attach bottom of Bracket assembly to hole in frame crossmember

12mm x 120mm Hex Bolt
12mm x 32mm STD Flat Washer

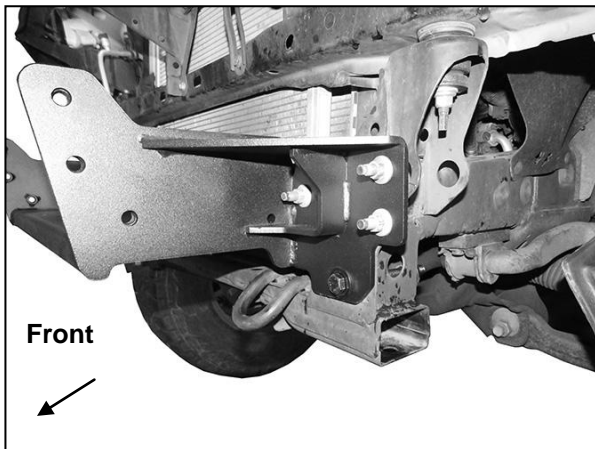

(Fig 8) Winch Tray/Bracket assembly installed (driver/left side pictured)

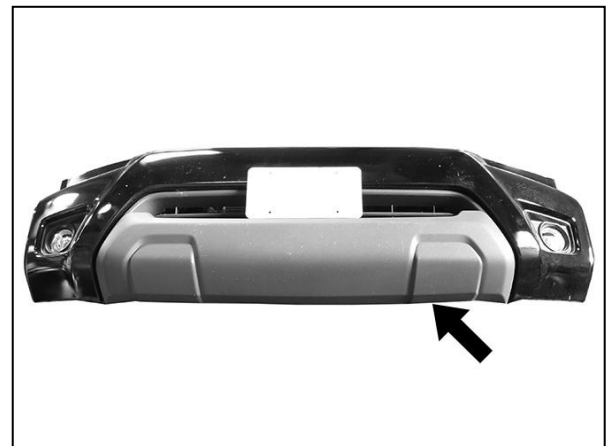

(Fig 9) Remove the outer plastic cover from bumper cover (arrow)

Driver/left Side Installation Pictured



(Fig 10) Lower cover removed



(Fig 11) Locate trim line in bumper cover (driver/left side pictured)



(Fig 12) Use a marker to draw a cut line along the trim line and edge of lip at top. NOTE: Cut edge will be covered with push on Edge Trim. (driver/left side pictured)

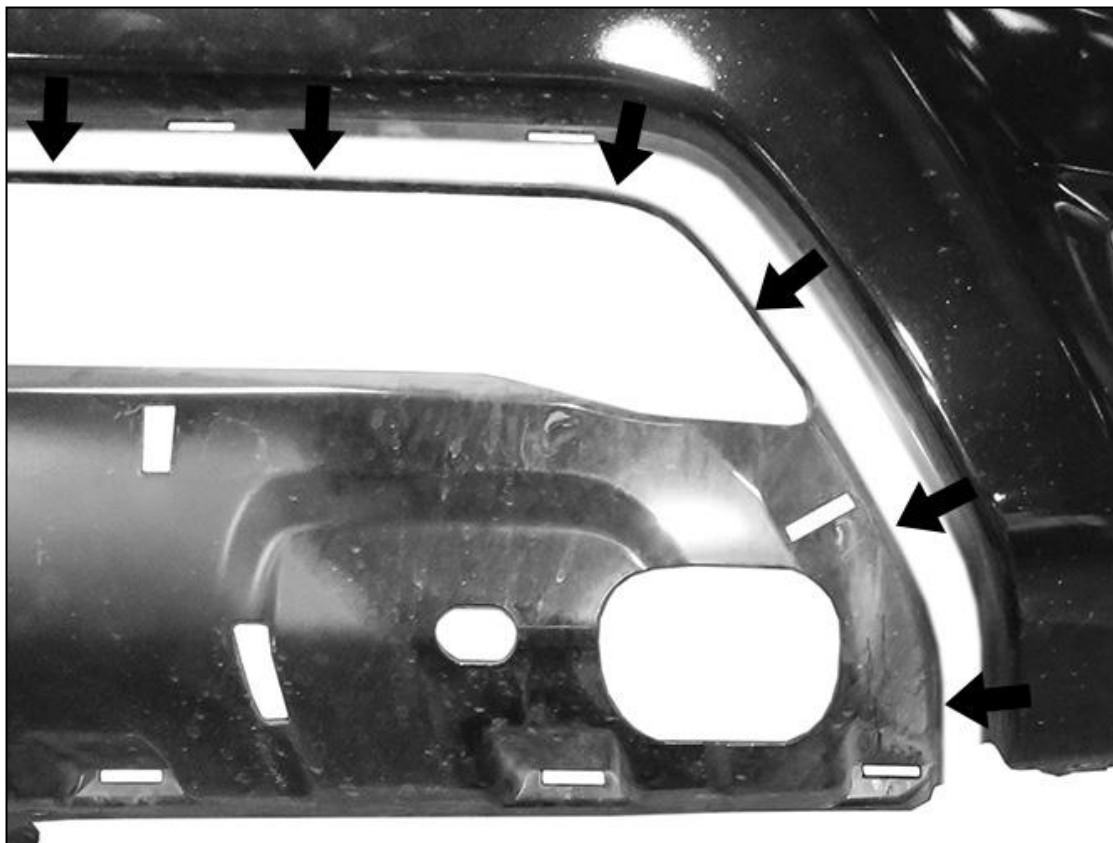

(Fig 13) Use a sharp knife or hacksaw blade to cut along cut line and remove lower section (diver/left side pictured)



(Fig 14) Reinstall bumper cover. Check fit between bumper cover and Winch Bumper and trim and adjust Bumper as necessary. Clean up rough edges along cut area and push Edge Trim over edge of bumper cover

- (2) 10mm x 30mm Button Head Bolts**
- (2) 10mm Flat Washers**
- (2) 10mm Nylon Lock Nuts**

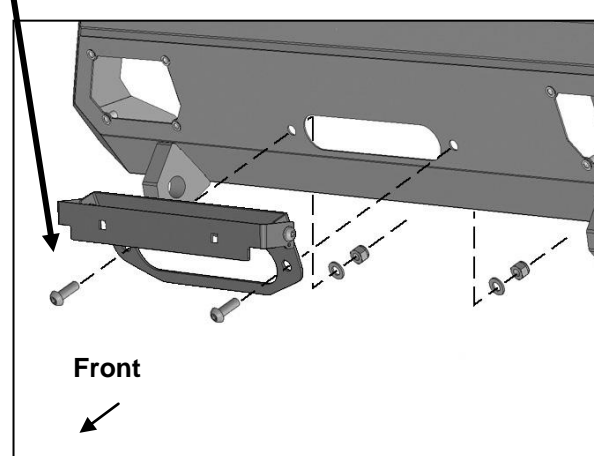

(Fig 15) Attach License Plate Bracket to front of Winch Bumper and cable guide (not pictured or included)

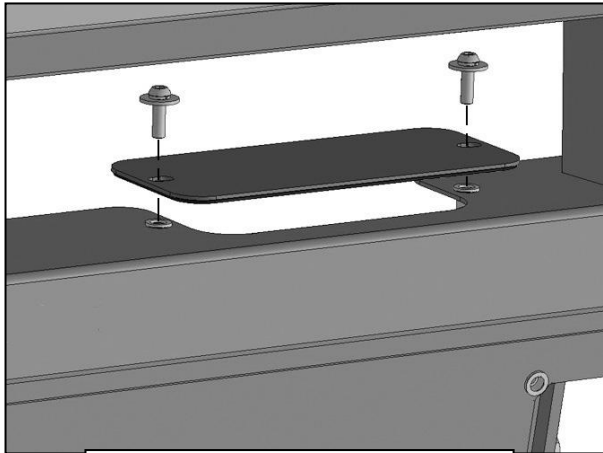

(Fig 16) Remove winch release lever Access Cover if needed

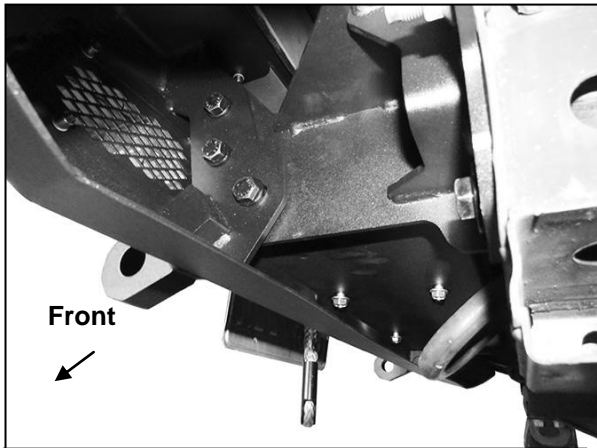

(Fig 18) Driver/left side of Bumper attached

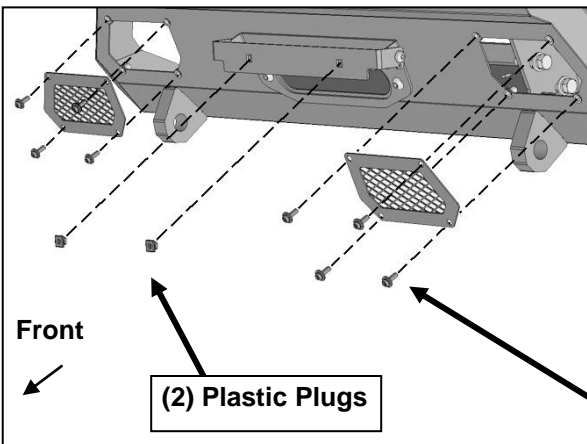

(Fig 20) Attach Mesh Fill Panels. Attach License Plate to Plastic Plugs

(2) Plastic Plugs

(8) 6mm Combo Bolts

WARNING! Do not crawl under bumper unless it is properly supported on blocks or stands or the bumper may fall.

(3) 12mm x 45mm Hex Bolts
(3) 12mm Lock Washers
(3) 12mm x 24mm Small Flat Washers

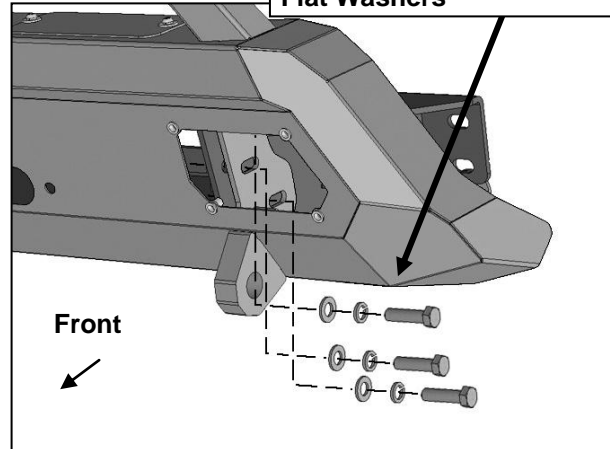

(Fig 17) Attach driver/left side of Bumper to outside of Bracket Winch Tray assembly

8mm x 16mm Hex Bolt
8mm Lock Washer
8mm Flat Washer

8mm x 25mm Hex Bolt
(2) 8mm Flat Washers
8mm Lock Washer
8mm Hex Nut

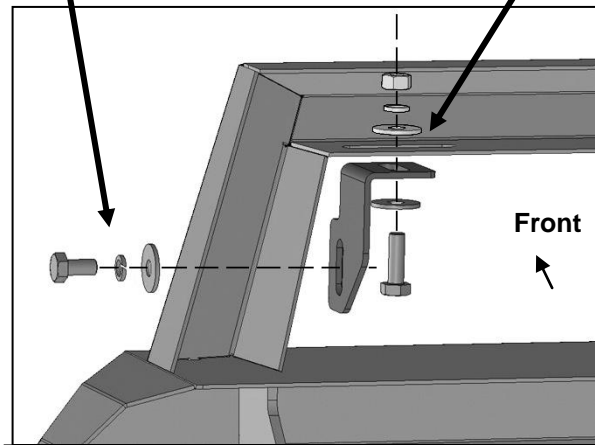

(Fig 19) Driver/left Top Light Bracket installed