

PART #P000029
Front Bumper for 18-21 Subaru Crosstrek
(20" double row LED light bar, no winch mount)

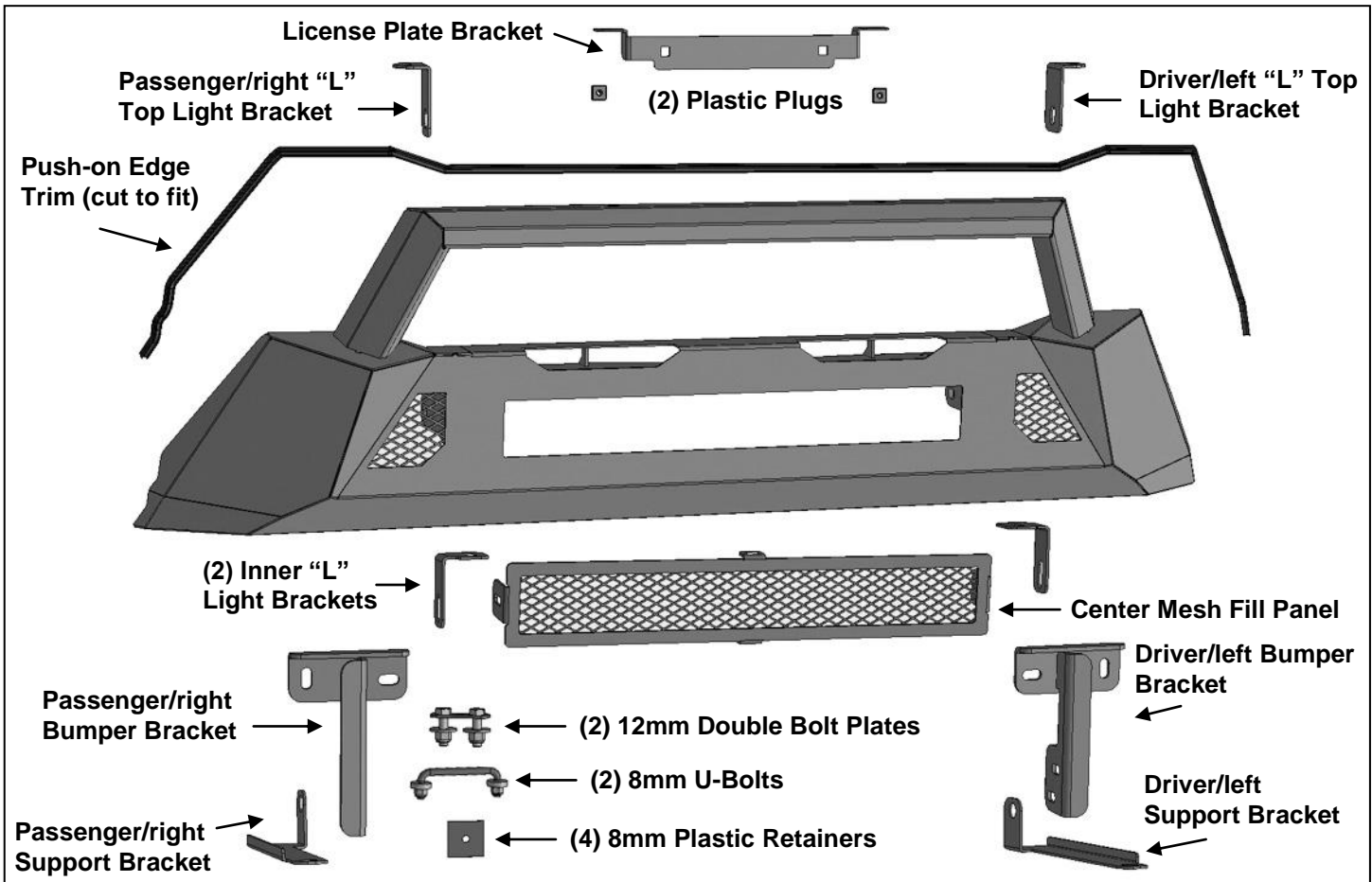

PARTS LIST:

1	CS1 LD Front Bumper Assembly	4	10mm x 30mm x 2.5mm Flat Washers
1	Driver/left Frame Mounting Bracket	4	10mm Nylon Lock Nuts
1	Passenger/right Frame Mounting Bracket	2	8-1.25mm U-Bolts
1	Driver/left Support Bracket	4	8mm Plastic Retainers
1	Passenger/right Support Bracket	8	8-1.25mm x 25mm Hex Bolts
1	Mesh Fill Panel	2	8-1.25mm x 20mm Hex Bolts
2	Inner Light Bar "L" Brackets	2	8-1.25mm x 16mm Hex Bolts
2	Bull Nose "L" Light Brackets	4	8mm x 24mm x 6mm THICK Spacers
1	License Plate Bracket	22	8mm x 24mm x 2mm STD Flat Washers
2	Plastic Plugs	12	8mm Lock Washers
1	Edge Trim (1600mm length cut to fit)	4	8mm Nylon Lock Nuts
2	12-1.75mm x 35mm Hex Bolts	10	8mm Hex Nuts
4	12mm x 32mm x 3mm Flat Washers	2	6mm x 20mm Button Head Combo Bolts
2	12mm Nylon Lock Nuts	2	6mm Flange Nuts
2	10-1.5mm x 35mm Double Bolt Plates	1	4mm Wrench



PROCEDURE:

REMOVE CONTENTS FROM BOX. VERIFY ALL PARTS ARE PRESENT. READ INSTRUCTIONS CAREFULLY BEFORE STARTING INSTALLATION. ASSISTANCE IS RECOMMENDED TO AVOID POSSIBLE INJURY OR DAMAGE TO THE VEHICLE.

1. Start at the passenger/right front wheel opening and remove the plastic push-in clip attaching the end of the bumper cover to the bottom of the front fender, **(Figure 1)**. Next, remove the plastic clips attaching the end and bottom of the bumper cover to the outer and center splash guards, **(Figure 2)**. Repeat this **Step** to remove the clip from the driver/left wheel opening.
2. Open the hood and remove the (6) plastic clips attaching the top of the plastic bumper cover and grille to the radiator support and next to the headlights, **(Figure 3)**.
3. Place a blanket under the bumper to protect the painted finish. With assistance, pop the ends of the bumper cover off of the inner clips at the wheel openings and under the headlights. Pull the bumper cover off the vehicle, **(Figure 4)**. Unplug the fog lights if equipped.
4. Move bumper cover to a soft, clean work surface.
5. Remove the plastic splash guard from the bottom of the vehicle, **(Figure 2)**.
6. Remove the foam bumper pad from the front of the steel impact bar, **(Figure 4)**.
7. Select (1) 8mm Long U-Bolt and (2) 8mm Plastic Retainers, **(Figure 6)**. Insert the U-Bolt into the large oval hole in the steel impact bumper and out the smaller round hole, **(Figure 5)**. Thread the Plastic Retainers onto the threaded ends of the U-Bolt to help hold the U-Bolt in place, **(Figures 6 & 7)**. Use of the Plastic Retainers is optional.
8. Select the passenger/right Bumper Bracket, **(Figure 8)**. Place the Bracket over the U-Bolt. Slide (2) **8mm x 6mm Thick Spacers** over the threaded ends. Attach the Bracket to the U-Bolt and Spacers with (2) 8mm Nylon Lock Nuts, **(Figure 9)**. Snug but do not fully tighten hardware. **IMPORTANT: Do Not Install the Bracket without the Spacers.**
9. Repeat **Steps 7 & 8** to install the driver/left Mounting Bracket, **(Figure 10)**.
10. Move to the back of the factory plastic bumper. Remove the lower foam bumper reinforcement and grille from the bumper, **(Figures 11 & 12)**.
11. Reinstall the factory bumper, **(Figure 13)**.
12. Next, carefully unwrap and move the CS-1 Front Bumper to a stable surface.
13. Slide the included Edge Trim onto the edge of the Bumper, **(Figure 14)**. Trim ends to fit Bumper profile.
14. Determine if LED bar style light, (light not included), or Mesh Fill Panel will be installed in center of Bumper.

Center LED light installation, (sold separately).

- a. Select the (1) Inner "L" Light Bracket, **(Figure 15)**. Use the provided (1) 8mm x 20mm Hex Bolt, (2) 8mm Flat Washers, (1) 8mm Lock Washer and (1) 8mm Hex Nut to attach the "L" Bracket to the mounting tab on the back of the Bumper, **(Figure 16)**. Leave hardware loose. Repeat to install the passenger/right Bracket.
- b. Attach the LED light assembly to the "L" Brackets.
- c. Adjust the light as necessary and tighten hardware.
- d. Follow the instructions included with the light to connect the wire harness to the vehicle.

Mesh Fill Panel Installation.

- a. Repeat the previous Steps to install the Inner "L" Brackets.
 - b. Attach the Mesh Fill Panel to the Inner "L" Brackets with (2) 8mm x 25mm Hex Bolts, (4) 8mm Flat Washers, (2) 8mm Lock Washers and (2) 8mm Hex Nuts, **(Figure 17)**. Attach the top and bottom of the Fill Panel to the tabs on the back of the Bumper with (2) 6mm Combo Bolts and (2) 6mm Flange Nuts.
 - c. Push Panel up against back of Bumper and tighten hardware.
15. With assistance, position the Bumper Assembly up to the inside of the Brackets. Temporarily support the weight of the Bumper. **WARNING: To avoid possible injury or damage to the vehicle, do not proceed until the bumper is fully and safely supported.**
 16. Attach the passenger/right side of the Bumper to the Bracket with (1) 10mm Double Bolt Plate, (2) 10mm Flat Washers and (2) 10mm Nylon Lock Nuts, **(Figures 18 & 19)**. Insert the Double Bolt Plate from the outside in through the Bracket first then Bumper. Leave hardware loose at this time. Repeat this **Step** to attach the driver/left side of the Bumper.
 17. Check fitment of the Bumper to the plastic bumper cover. Align and adjust as necessary and tighten the Bumper to Bracket hardware.

18. Next, locate the passenger/right tie down loop, **(Figure 20)**. Select the passenger/right Support Bracket, **(Figure 21)**. Attach the rear tab on the Support Bracket to the inside of the tie down loop with (1) 12mm x 35mm Hex Bolt, (2) 12mm Flat Washers and (1) 12mm Nylon Lock Nut, **(Figure 22)**. Attach the front flat end of the Bracket to the bottom of the Bumper with (1) 8mm x 25mm Hex Bolt, (2) 8mm Flat Washers, (1) 8mm Lock Washer and (1) 8mm Hex Nut, **(Figures 23 & 24)**. Tighten hardware. Repeat this Step to attach the driver/left Support Bracket.
19. Reinstall the plastic splash guard, **(Figure 25)**.
20. **Top LED light installation (optional, light not included)**. Select the (1) passenger/right "L" Top Light Bracket, **(Figure 26)**. Use the provided (1) 8mm x 25mm Hex Bolt, (2) 8mm x 24mm Flat Washers and (1) 8mm Lock Washer and (1) 8mm Hex Nut to attach the "L" Bracket to the mounting tab. Repeat to install the driver/left Bracket. Follow instructions packaged with light to attach light to Brackets.
21. On models with front license plate, attach the included License Plate Bracket to the Hoop on the Bumper with the included (2) 8mm x 25mm Hex Bolts, (4) 8mm x 24mm Flat Washers, (2) 8mm Lock Washers and (2) 8mm Hex Nuts, **(Figure 27)**. **NOTE:** License Plate Bracket can be installed on the top or the underside of the Bull Nose Hoop. Insert (2) Plastic Plugs into the square holes in the License Plate Bracket. Reuse the factory hardware to attach the plate to the Plugs, **(Figure 28)**.
22. Do periodic inspections to the installation to make sure that all hardware is secure and tight.

To protect your investment, Do not use any type of polish or wax that may contain abrasives that could damage the finish. Mild soap may be used to clean the Bumper assembly.

Passenger/right side Installation Pictured



(Fig 1) Remove clips attaching ends and bottom of plastic bumper cover (arrow)



(Fig 2) Remove clips attaching bottom of plastic bumper cover. Remove splash guard from bottom of engine

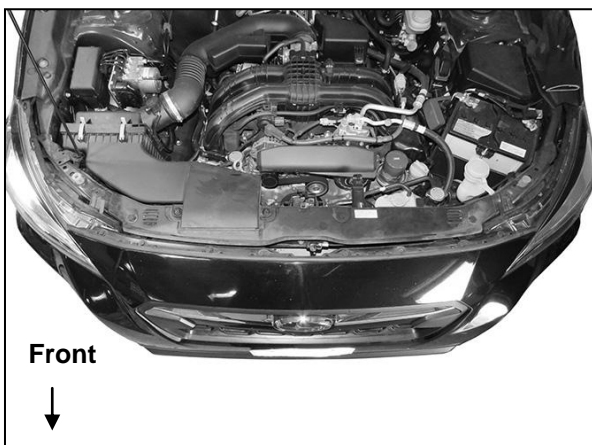

(Fig 3) Remove clips attaching top of grille. Pull bumper cover at ends and below headlights to release inner clips. Unplug fog lights if equipped

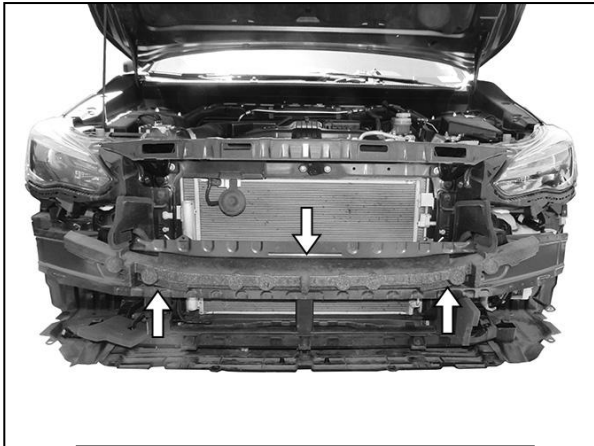

(Fig 4) Remove the foam pad from the impact bumper (arrows)

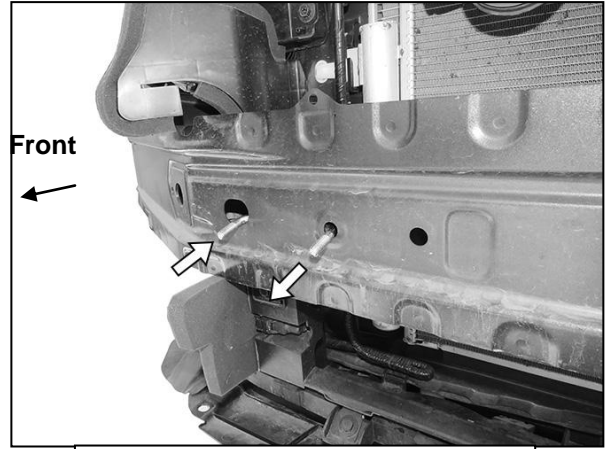

(Fig 5) Insert U-Bolt into larger oval hole and out round hole (arrows)

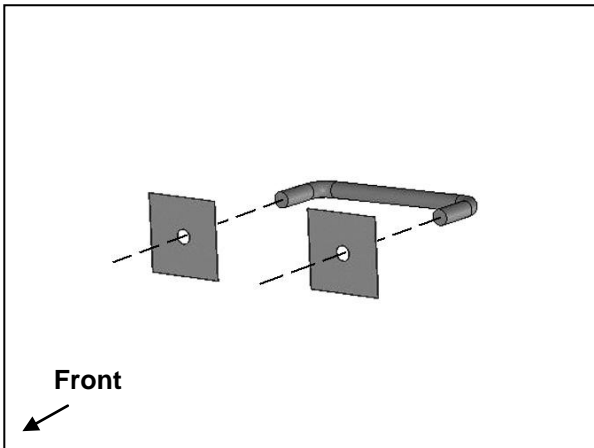

(Fig 6) Thread Plastic Retainers onto U-Bolt

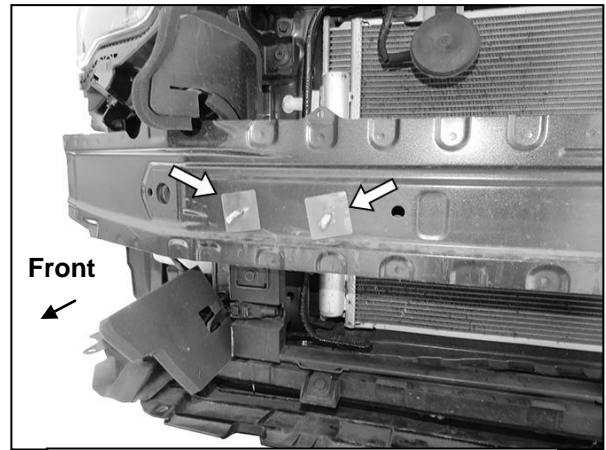

(Fig 7) Plastic Retainers used to hold U-Bolt in place (arrows)

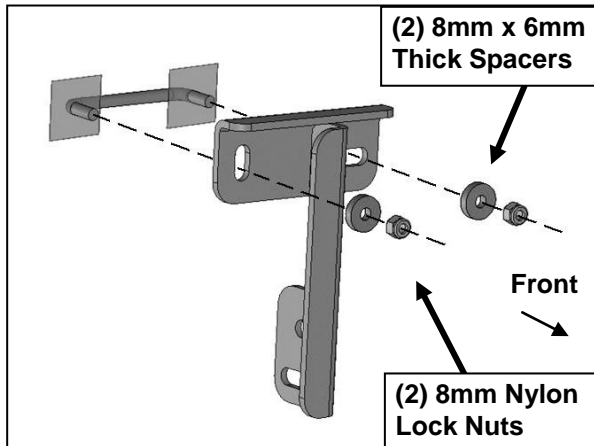

(Fig 8) Attach passenger/right Frame Bracket to U-Bolt

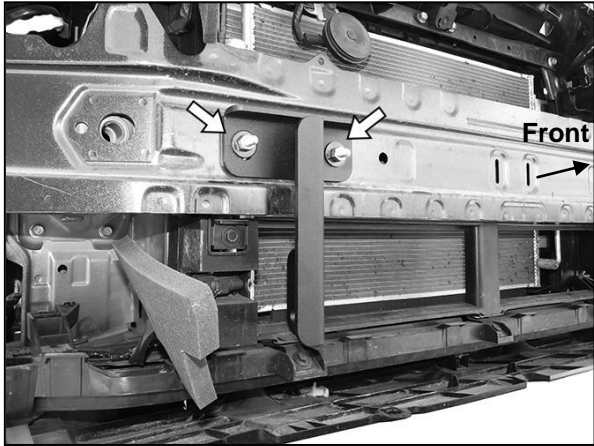

(Fig 9) Passenger/right Frame Bracket installed

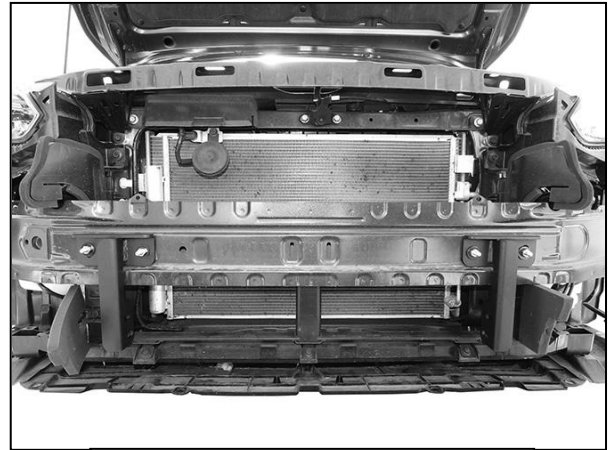

(Fig 10) Frame Brackets installed

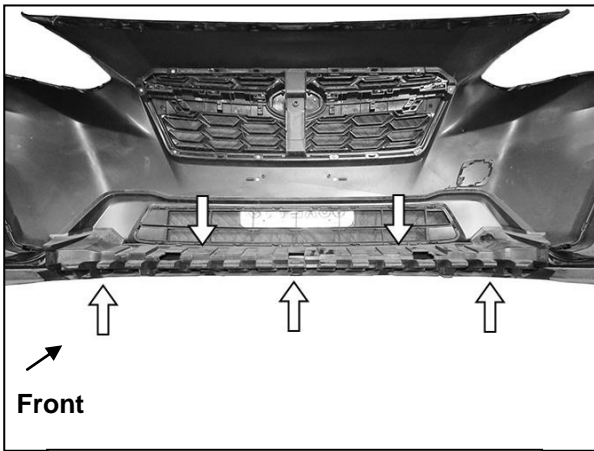

(Fig 11) Remove foam reinforcement from back of bumper cover (arrows)

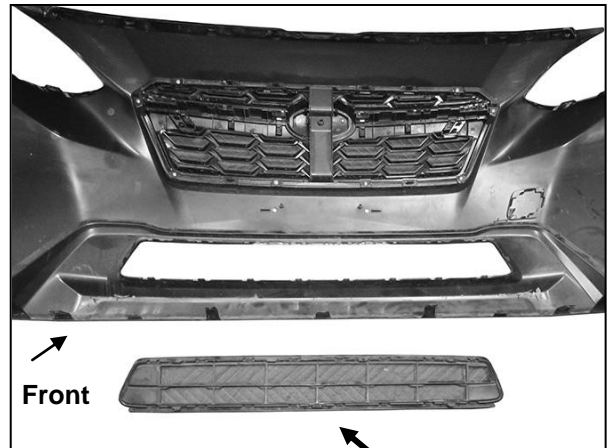

(Fig 12) Remove grille from bumper cover

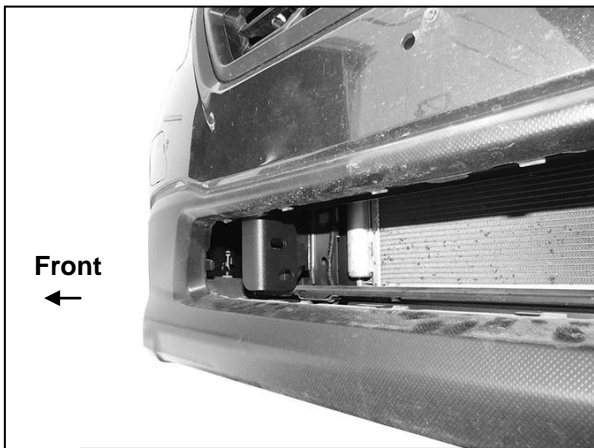

(Fig 13) Reinstall bumper cover (passenger/right side pictured)

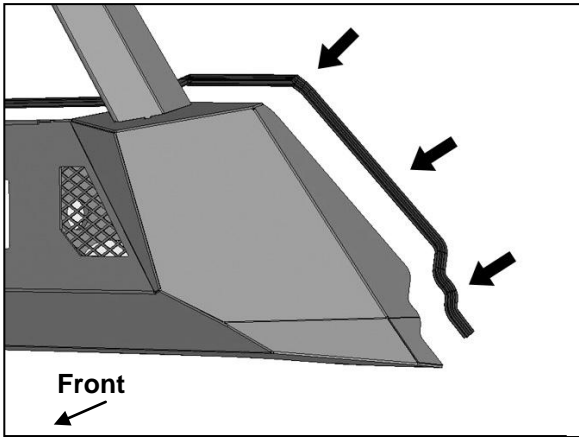

(Fig 14) Push Edge Trim onto edge of CS1 Bumper. Cut to length as needed



(Fig 15) Inner "L" Bracket (left) and Top "L" Bracket (right)

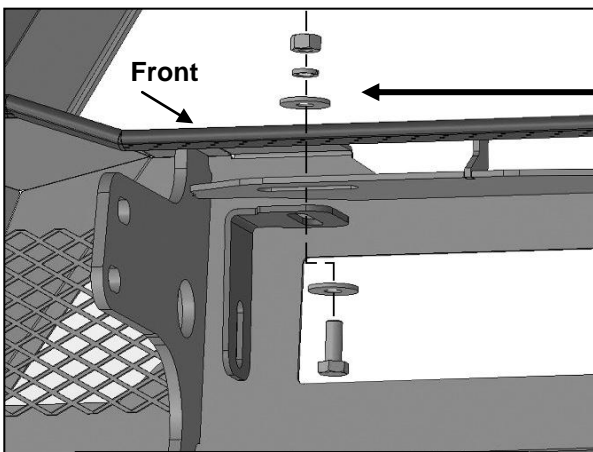

(Fig 16) Attach inner "L" Brackets for LED light or Mesh Panel

- 8mm x 20mm Hex Bolt
- (2) 8mm Flat Washers
- 8mm Lock Washer
- 8mm Hex Nut

- (2) 8mm x 25mm Hex Bolts
- (4) 8mm Flat Washers
- (2) 8mm Lock Washers
- (2) 8mm Hex Nuts

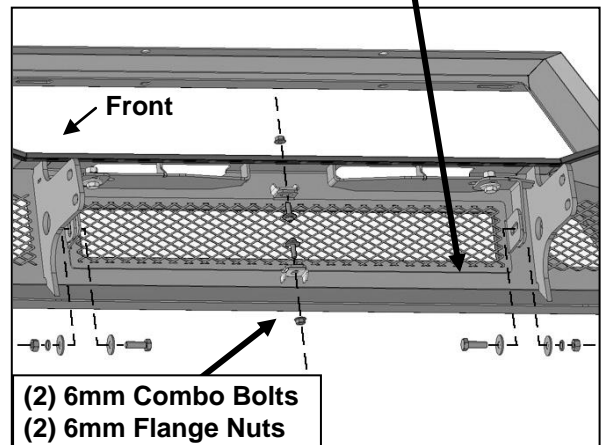

- (2) 6mm Combo Bolts
- (2) 6mm Flange Nuts

(Fig 17) Attach Mesh Fill Panel to "L" Brackets if desired

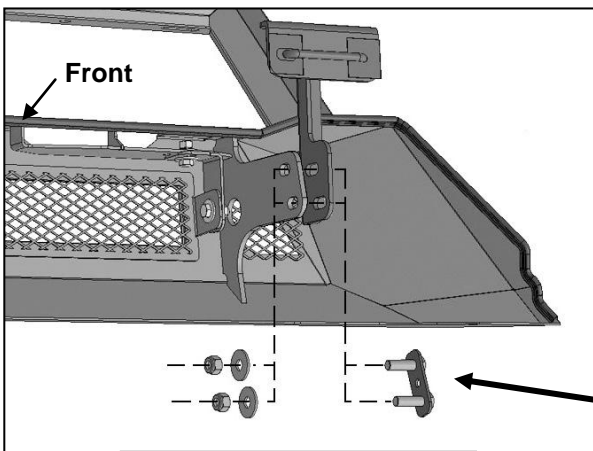

(Fig 18) Attach Bumper to the inside of the Brackets

- 10mm Double Bolt Plate
- (2) 10mm Flat Washers
- (2) 10mm Nylon Lock Nuts

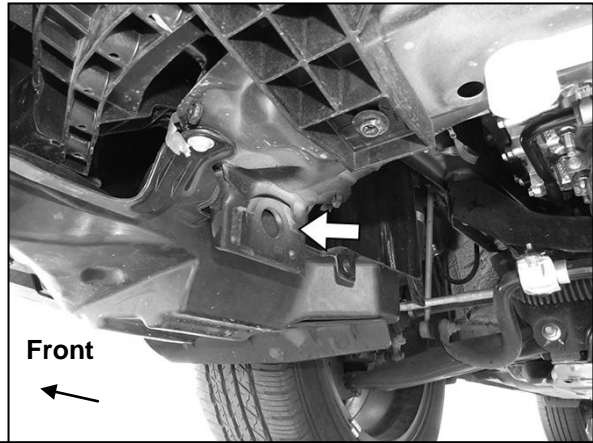

(Fig 20) Passenger/right tie down bracket (arrow)

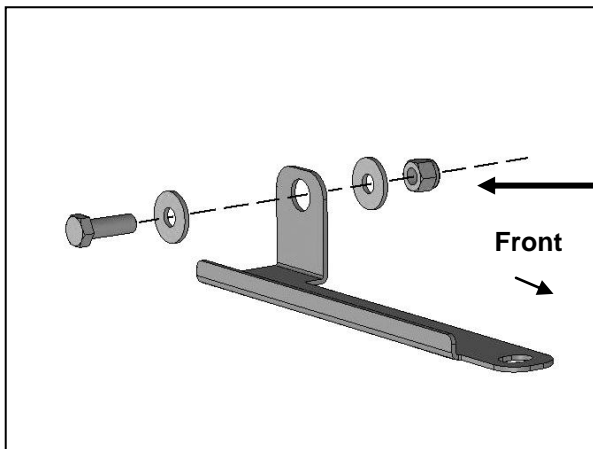

- 12mm x 35mm Hex Bolt
- (2) 12mm Flat Washers
- 12mm Nylon Lock Nut

(Fig 21) Attach passenger/right Support Bracket to inside of tie down bracket (fig 19)

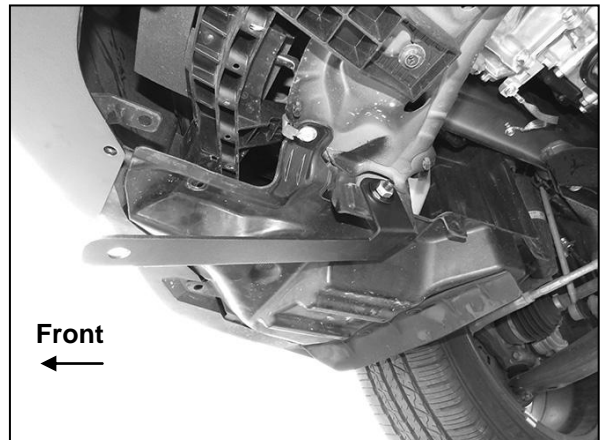

(Fig 22) Support attached to tie down bracket

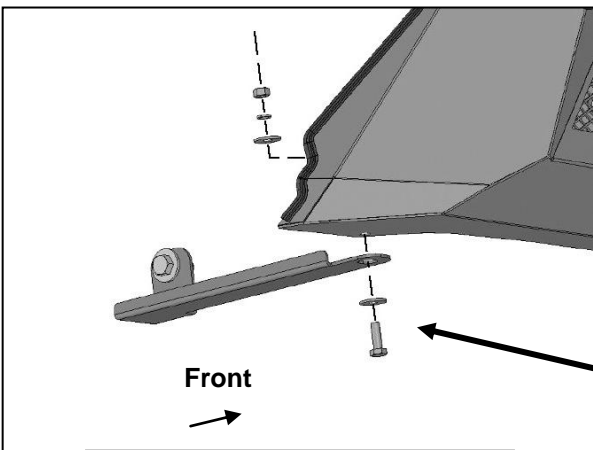

- 8mm x 25mm Hex Bolt
- (2) 8mm Flat Washers
- 8mm Lock Washer
- 8mm Hex Nut

(Fig 23) Attach Support Bracket to bottom of CS1 Bumper

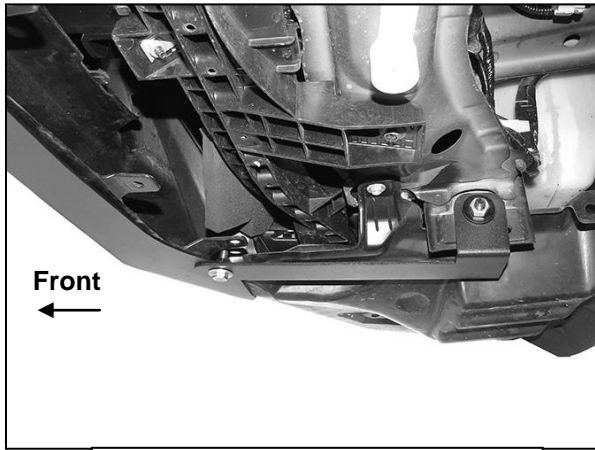

(Fig 24) Support Bracket installed

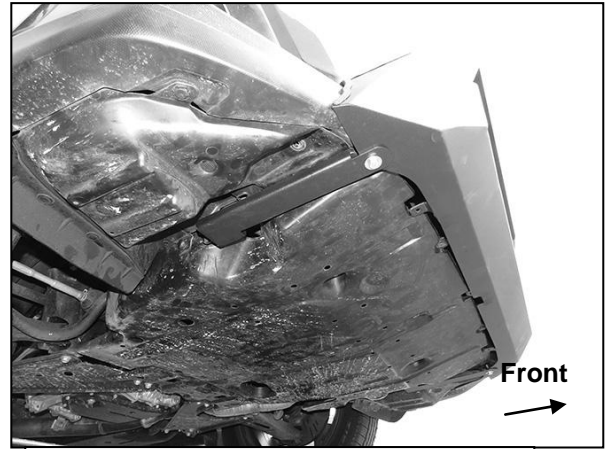

(Fig 25) Reinstall plastic splash guard

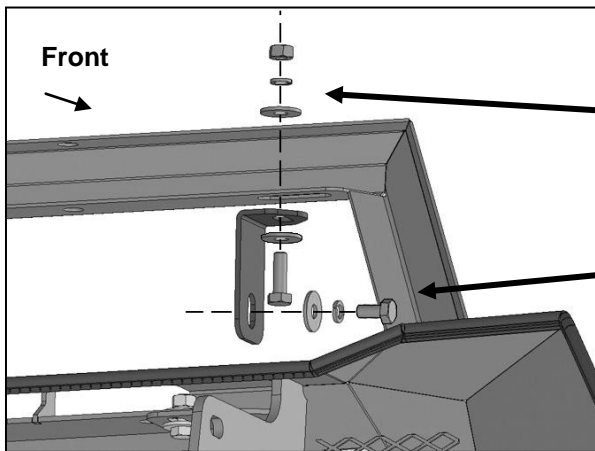

(Fig 26) Attach top "L" LED Brackets to hoop

- 8mm x 25mm Hex Bolt
- (2) 8mm Flat Washers
- 8mm Lock Washer
- 8mm Hex Nut

- 8mm x 16mm Hex Bolt
- 8mm Lock Washer
- 8mm Flat Washer

- (2) 8mm x 25mm Hex Bolts
- (4) 8mm Flat Washers
- (2) 8mm Lock Washers
- (2) 8mm Hex Nuts

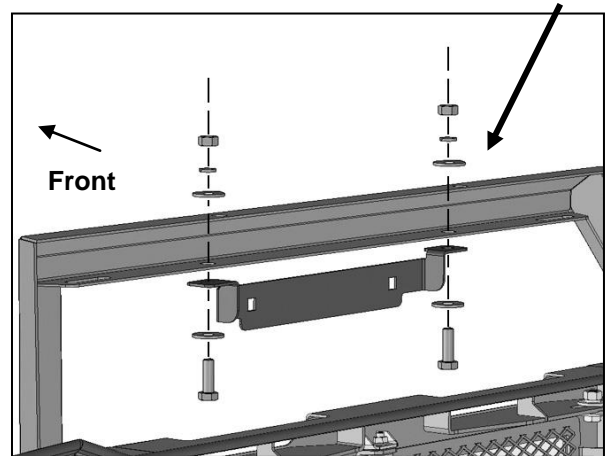

(Fig 27) Attach License Plate Bracket to top or bottom of Bull Nose Hoop (optional)

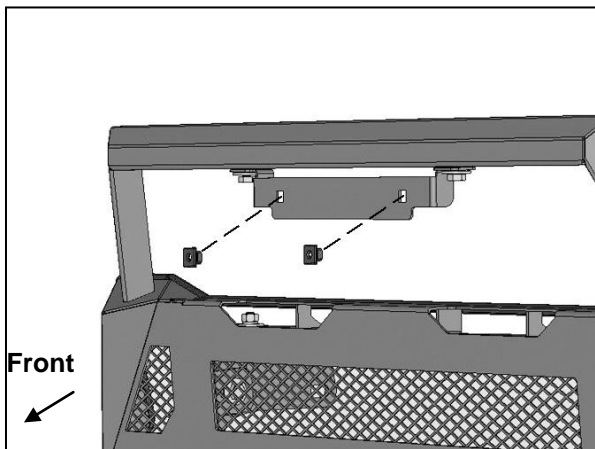

(Fig 28) Insert Plugs into License Plate Bracket