

S5087

2019-UP GMC/CHEV 1500, 4.3L/5.3L,
3" CAT BACK SINGLE

MBRP INC.
PERFORMANCE EXHAUST

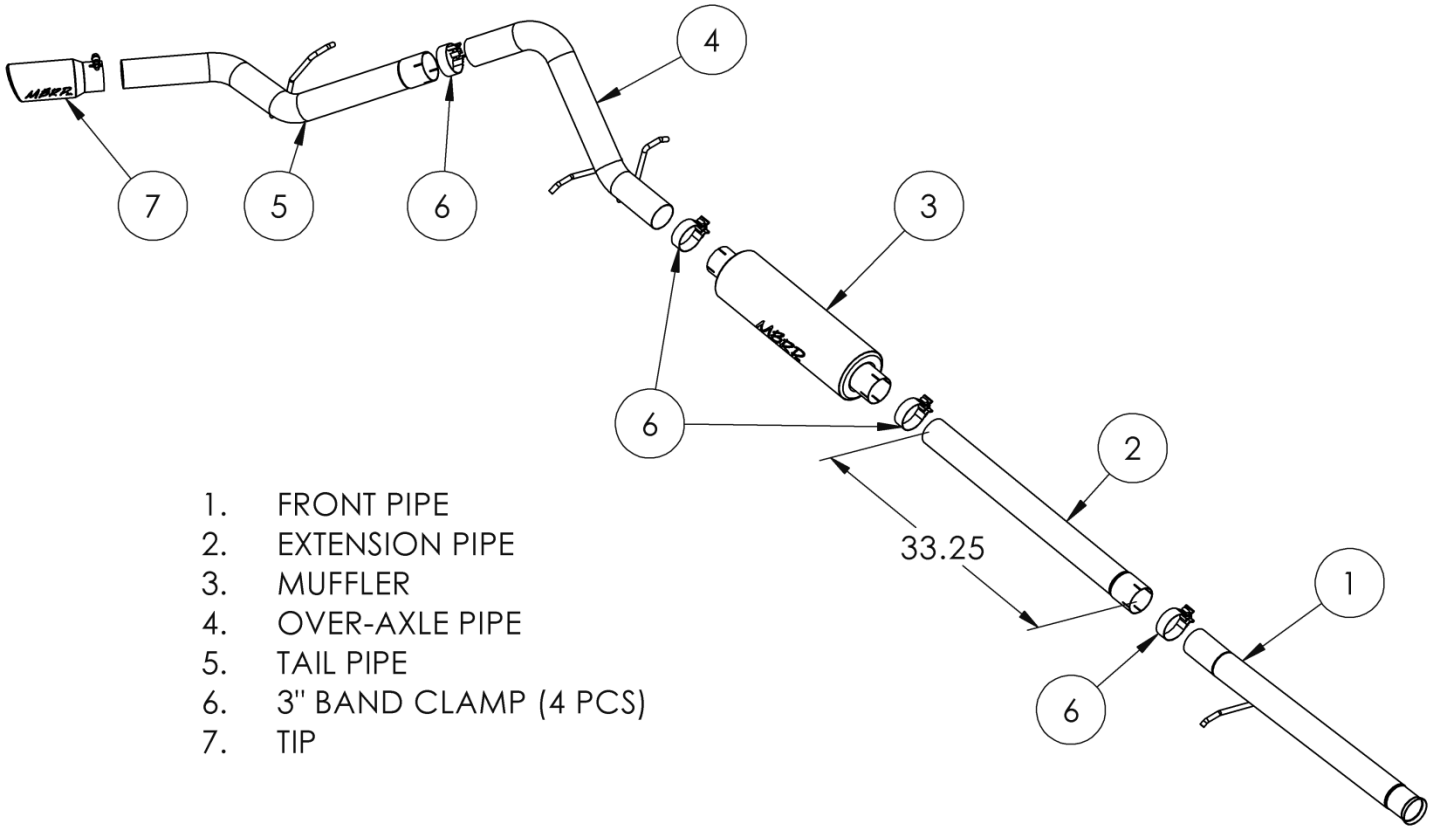

PLEASE READ BEFORE STARTING INSTALLATION

While MBRP Inc. has made every effort to ensure that all components of this system are of superior quality and properly packaged, it is the installer's responsibility to ensure the following before removal of the factory exhaust:

- that ALL components shown above are present.
- that ALL mating components fit together.
- that there are no damaged components.
- that the system you have purchased is appropriate for your vehicle year, model and configuration.
- that the system will not interfere with any modifications previously installed or planned.
- that you have read and understand these instructions.

If you have any questions or are uncertain about any aspect of the installation of this system to your vehicle please contact your dealer before commencing installation.

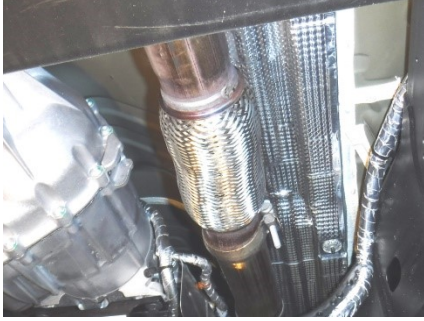

Figure 1

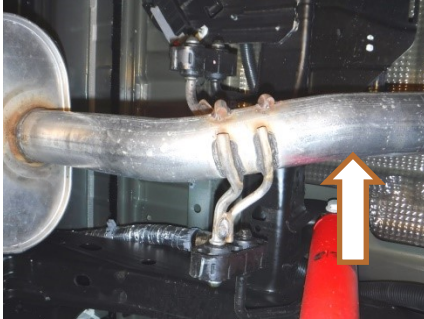

Figure 2

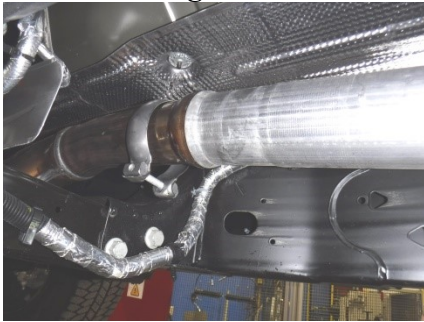

Figure 3



Figure 5



Figure 6

Removal of Stock System

1. Apply penetrating lubricant liberally to all exhaust fasteners, hangers and rubber insulators.

2. Remove the clamp after the catalytic converter and save the clamp for the installation.

Refer to Figure 1.

3. Remove the hangers from the rubber insulators and remove the exhaust from the vehicle. The tail pipe can be cut to ease clearing the rear axle.

Refer to Figure 2.

Installation of MBRP Inc. Performance Exhaust

1. Using the factory clamp removed in Step 2, loosely attach the **Front Pipe** onto the catalytic converter and into the rubber insulator.

Refer to Figure 3.

2. Determine the length of the **Extension Pipe** (if required) and cut to length. **Refer to Figure 4 (below).**

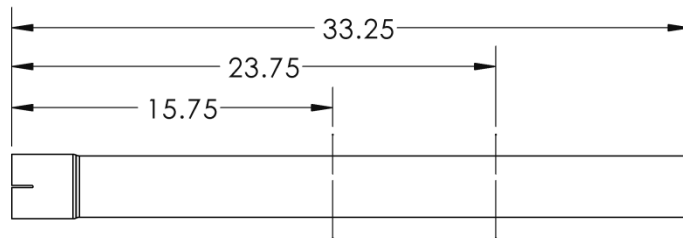

EXTENSION PIPE

WHEELBASE	EXTENSION PIPE LENGTH
126.4 RC 6'6" BOX	NOT USED
139.5 RC 8' BOX	15.75"
147.4 EC 6'6" BOX / CC 5'8" BOX	23.75"
156.9 CC 6'6" BOX	33.25" (NO CUT)

Figure 4.

3. Using a **3" Clamp**, loosely install the **Extension Pipe**. **Refer to Figure 5.**

4. Using a **3" Clamp**, loosely install the **Muffler** onto the **Extension Pipe**.

5. Using a **3" Clamp**, loosely install the **Over-Axle Pipe** into the **Muffler** and into the factory insulators.

Refer to Figure 6.



Figure 7

6. Using a **3" Clamp**, loosely install the **Tail Pipe** onto the **Over-Axle Pipe** and into the factory rubber isolator.
Refer to Figure 7.

7. Install the **Tip**, and adjust to your liking.
Refer to Figure 8.

8. Tighten all hardware and clamps, starting at the front and working rearward to secure the system. Ensure the **Front Pipe Hanger** is level where it passes through the rubber insulator. Check along the full length of the exhaust system to ensure there is adequate clearance for fuel lines, brake lines, frame, bodywork, suspension and any wiring, etc. If there is any interference detected, relocate or adjust to provide adequate clearance.



Figure 8



Congratulations! You are ready to begin experiencing the improved power, sound and driving experience of your *MBRP Inc.* Performance Exhaust.

We know you will enjoy your purchase!