

# S5143

2019-UP DODGE RAM 1500, 5.7 HEMI, 3"  
SINGLE IN/OUT MUFFLER REPLACEMENT

# MBRP

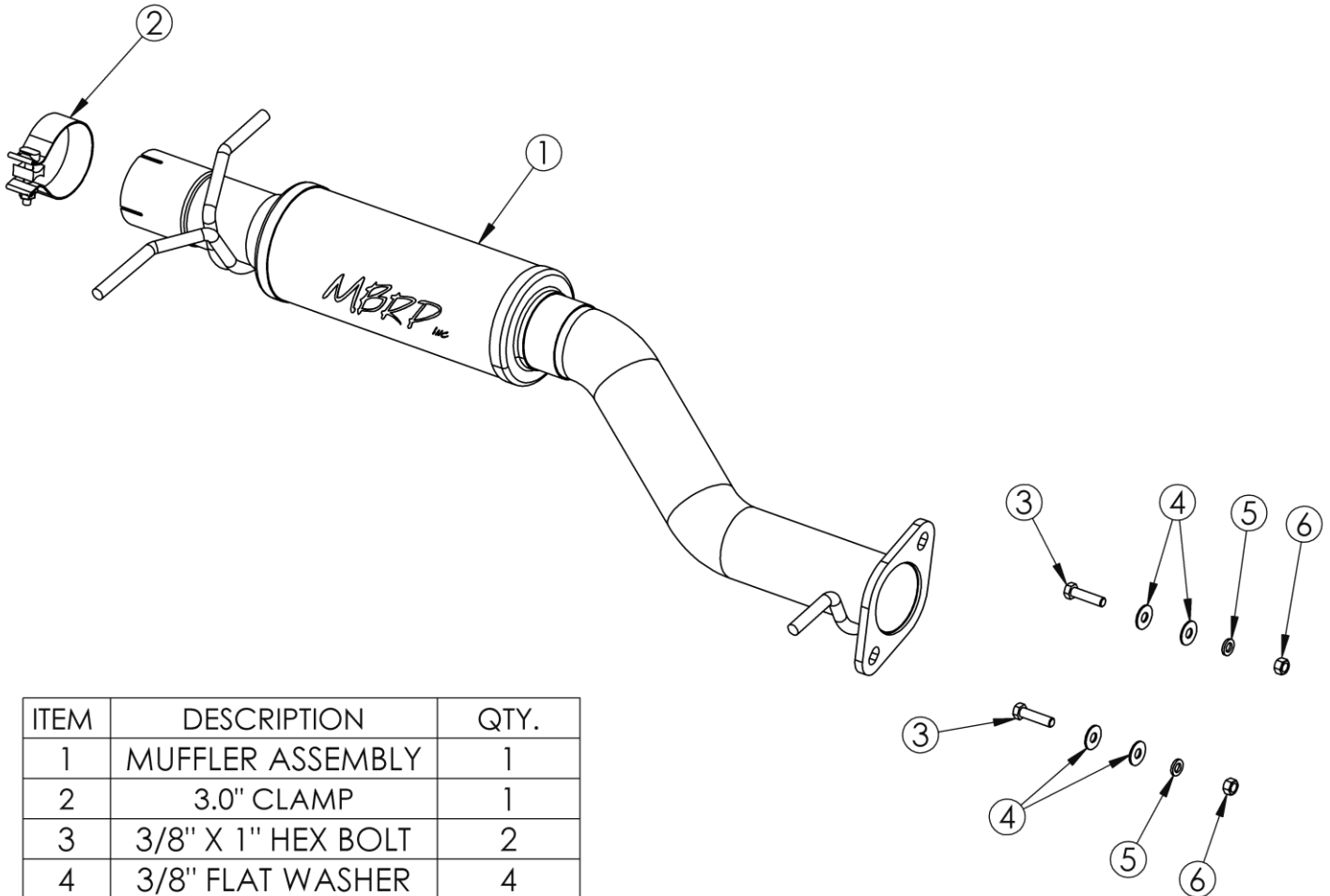

ITEM	DESCRIPTION	QTY.
1	MUFFLER ASSEMBLY	1
2	3.0" CLAMP	1
3	3/8" X 1" HEX BOLT	2
4	3/8" FLAT WASHER	4
5	3/8" LOCK WASHER	2
6	3/8" HEX NUT	2

## PLEASE READ BEFORE STARTING INSTALLATION

While MBRP Ltd. has made every effort to ensure that all components of this system are of superior quality and properly packaged, it is the installer's responsibility to ensure the following before removal of the factory exhaust:

- that ALL components shown above are present.
- that ALL mating components fit together.
- that there are no damaged components.
- that the system you have purchased is appropriate for your vehicle year, model and configuration.
- that the system will not interfere with any modifications previously installed or planned.
- that you have read and understand these instructions.

If you have any questions or are uncertain about any aspect of the installation of this system to your vehicle please contact your dealer before commencing installation.

# MBRP

**Note: replaces factory rear exit duals muffler**

## **Removal of stock system:**



**Figure 1**

1. Apply a penetrating lubricant liberally to all hangers, hardware and rubber isolators.



**Figure 2**

2. Remove both OEM tips from the truck.

3. Loosen the passenger-side tailpipe clamp before removing the hanger from the rubber isolator. Remove the passenger-side tailpipe assembly.

**Refer to Figure 1.**



**Figure 3**

4. Remove the driver-side upper sway bar link bolt and move the link to the side. The truck must be supported allowing the rear axle to 'droop' in order to provide clearance for removal of the driver-side tailpipe/muffer assembly.

**Refer to Figure 2.**

5. Remove both nuts securing the muffer hanger bracket to the crossmember, keep these nuts as they are required for the install. Remove the front hanger and driver-side tailpipe hanger from the factory muffer assembly. Remove the assembly from the truck.

**Refer to Figure 3.**

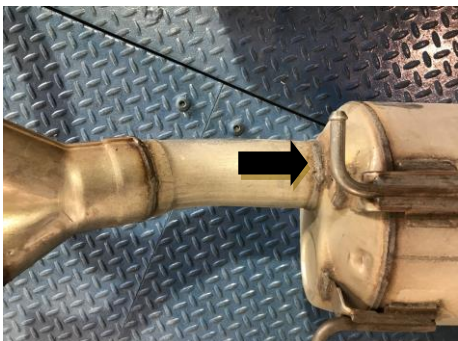

**Figure 4**

6. Remove the two bolts securing the factory muffer and remove the muffer, keeping the gasket as it will be needed for the install.

**Refer to Figure 4.**

## **Installation of MBRP Performance Exhaust:**



**Figure 5**

1. Cut the factory muffer 1" behind the muffer outlet weld bead.

**Refer to Figure 5.**

2. Install the factory hanger bracket onto the **Muffer Assembly**.

**Refer to Figure 6.**

# MBRP



**Figure 6**

3. Install the **Muffler Assembly** onto the factory front pipe using the gasket previously removed, installing it with the supplied **3/8" Hardware**.

**Refer to Figure 7&8.**

4. Reinstall the factory driver-side tail pipe into the **Muffler Assembly** outlets and secure them with the supplied **3.0" Clamp**.

**Refer to Figure 9.**

5. Reinstall the factory passenger-side tail pipe.

6. Reinstall the driver-side upper sway bar link.

7. Tighten all hardware and clamps, starting at the front and working rearward to secure the system. Check along the full length of the exhaust system to ensure there is adequate clearance for fuel lines, vent lines, brake lines, frame, bodywork, suspension and any wiring, etc. If there is any interference detected, relocate or adjust to provide adequate clearance. Ensure all clamp connections are secure and components are unable to rotate or slide. Band clamps require approximately 45 lb-ft (60 N-m) of torque. Verify clearances, system security and band clamp torque after 30-60 miles (50-100 km) of driving.



**Figure 7**

**Congratulations!** You are ready to begin experiencing the improved power, sound and driving experience of your **MBRP** performance exhaust system. We know you will enjoy your purchase.



**Figure 8**



**Figure 9**