

S6150PLM

88-93 DODGE 2500/3500 5.9L CUMMINS, TURBO BACK, 4" SINGLE SIDE (4WD ONLY)

MBRP®

28 - DEC - 2020

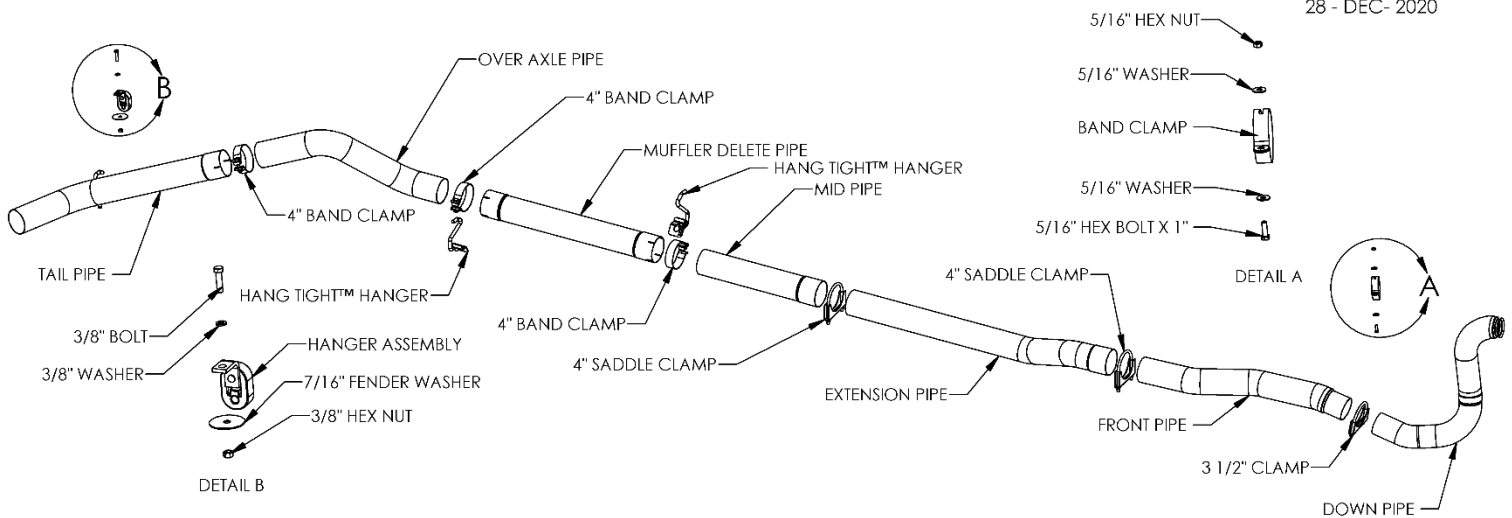

PLEASE READ BEFORE STARTING INSTALLATION

MBRP Ltd. has made every effort to ensure that all components of this system are of superior quality and properly packaged. It is the installer's responsibility to ensure that all components are present and fit together as shown. Please also ensure that all components are undamaged before removal of the factory exhaust. Finally, check that this system properly matches the make and model of the vehicle and will not interfere with previous or planned modifications.

Removal of Stock System:

1. Apply a penetrating lubricant liberally to all exhaust fasteners, hangers and rubber insulators.
2. Remove the exhaust system from the rubber insulators and remove all of the clamps from the system.
3. Separate the slip joint behind the muffler and remove the tail pipe. Finally loosen the band clamp connecting the down pipe to the turbo and remove the down pipe. **Do not discard the band clamp as it is required for the installation.**
4. The tail pipe hanger and bracket can be removed and returned to the customer.

Installation of MBRP Performance Exhaust:

1. Install the **Down Pipe** in the same position as the stock down pipe attaching the flared end to the turbo using the stock band clamp. Do not fully tighten until all components are in place. The **3 1/2" Clamp** is used to attach the **Down Pipe** to the existing mount.
2. Install the **Front Pipe** onto the **Down Pipe** using the **3 1/2" Clamp**.
3. Install the **Extension Pipe** by attaching it to the **Front Pipe** and securing it with a **4" Saddle Clamp** that is provided. The **Extension Pipe** may require trimming depending on the vehicle's wheelbase. The longer wheelbases in the Regular Cab Long Box will require the **Mid Pipe**. The **Mid Pipe** is connected to the **Extension Pipe** and secured using a **4" Saddle Clamp**.

Installation Tip: Temporarily install the **Muffler Delete Pipe** and **Tail Pipe** using the factory rubber insulators and the **4" Hang Tight™ Hanger**. (See **Figure 1** for Hang Tight instructions) Measure from the **Muffler Delete** to the **Extension Pipe** to determine the length of the pipes required (leave 3" overlap for each joint). Cut the pipes to the required length.

4. Install the **Muffler Delete** over the **Extension Pipe** so that the exhaust will flow smoothly over the louvers. Attach the **Muffler Delete Pipe** using the **4" Hang Tight™ Hanger**. Install the **4" Hang Tight™ Hanger** into the existing rubber isolators.

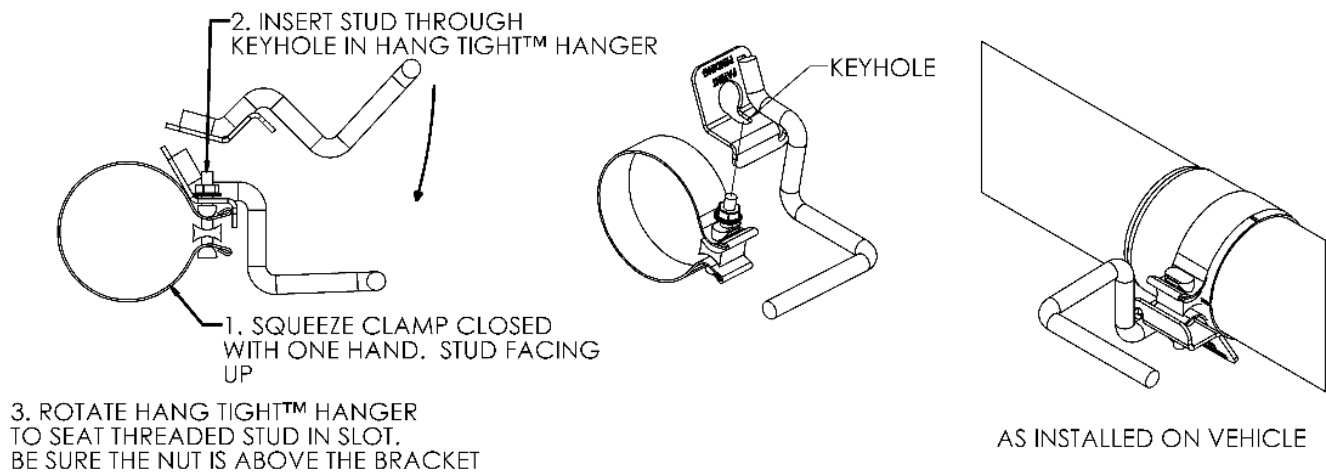

Figure 1 (Hang Tight™ Hanger not exactly as shown).

5. Install the **Over Axle Pipe** into the **Muffler Delete Pipe**.
6. Install the **Hanger Assembly** using the **3/8" Bolt, Lock Washer, Nut** and the **7/16" Fender Washer**.
7. Install the **Tail Pipe** to the **Over Axle Pipe** using the remaining **4" Band Clamp**.
8. Adjust the **Tail Pipe** and check along the whole length of the exhaust system to ensure there is adequate clearance around the fuel and brake lines or any wiring. If any interference is detected relocate or adjust. Start at the front of the exhaust system and begin tightening all connections.
9. Tighten all hardware and clamps, starting at the front and working rearward to secure the system. Check along the full length of the exhaust system to ensure there is adequate clearance for fuel lines, vent lines, brake lines, frame, bodywork, suspension, and any wiring, etc. If there is any interference detected, relocate, or adjust to provide adequate clearance. Ensure all clamp connections are secure and components are unable to rotate or slide. Band clamps require approximately 45 lb-ft (60 N-m) of torque. Verify clearances, system security and band clamp torque after 30-60 miles (50-100 km) of driving.

Congratulations! You are ready to begin experiencing the improved power, sound and driving experience of your **MBRP** performance exhaust system. We know you will enjoy your purchase.