

# S7215

2016-UP MUSTANG GT350 RESONATOR  
DELETE

# MBRP®

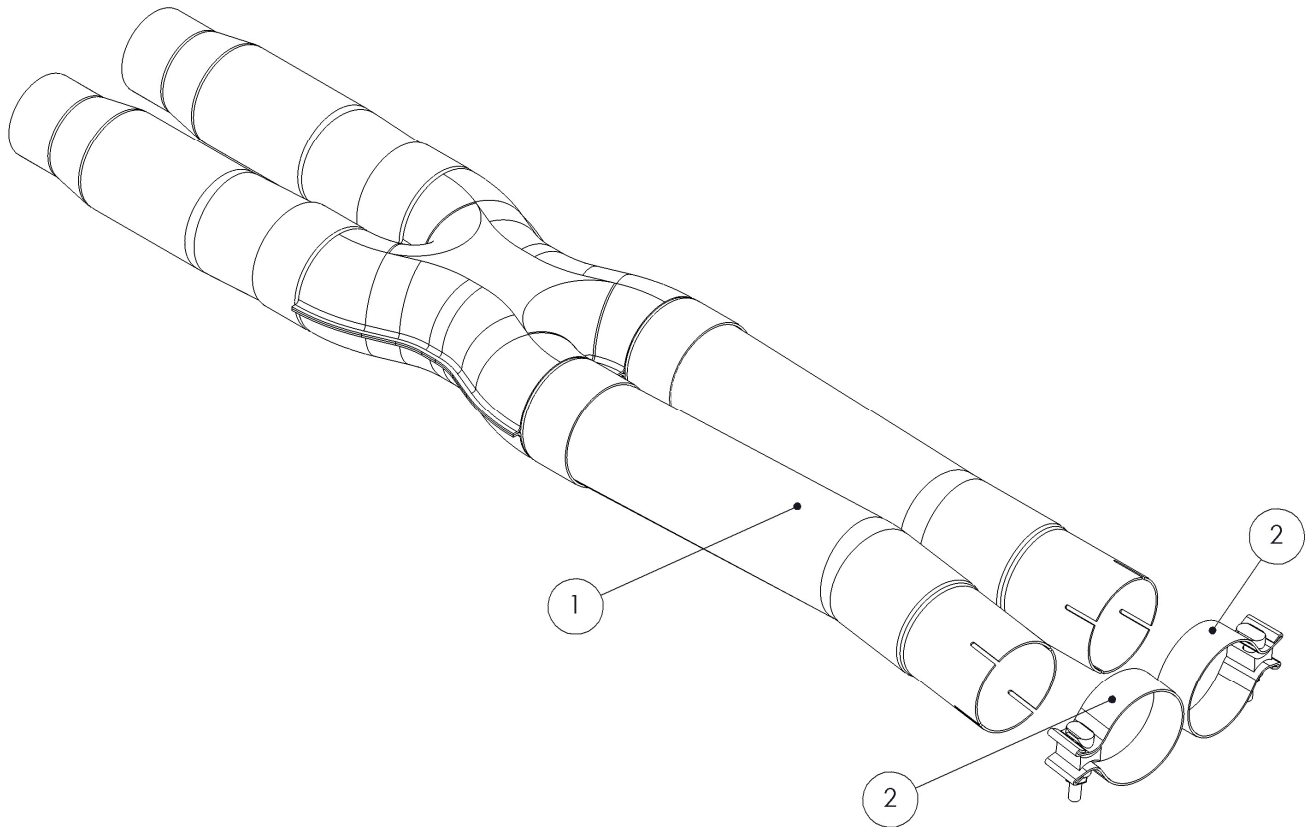

1. RESONATOR DELETE ASSEMBLY
2. 2.75" CLAMP [2 PCS]

## PLEASE READ BEFORE STARTING INSTALLATION

While MBRP has made every effort to ensure that all components of this system are of superior quality and properly packaged, it is the installer's responsibility to ensure the following before removal of the factory exhaust:

- that ALL components shown above are present.
- that ALL mating components fit together.
- that there are no damaged components.
- that the system you have purchased is appropriate for your vehicle year, model and configuration.
- that the system will not interfere with any modifications previously installed or planned.
- that you have read and understand these instructions.

If you have any questions or are uncertain about any aspect of the installation of this system to your vehicle please contact your dealer before commencing installation.

# MBRP

## Installation of MBRP Performance Exhaust

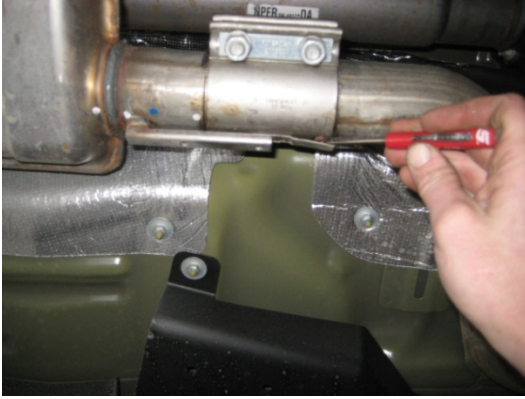

**Figure 1**



**Figure 2**



**Figure 3**



**Figure 4**

1. Loosen both OEM clamps and disconnect the cat back section of the exhaust from both front pipes. Allow the inlet of the cat back to hang down.

**Refer to Figure 1.**

2. Position the **Resonator Delete Assembly** underneath the OEM cat back being sure the inlets are aligned flush with each other. Note that the outlets of **Resonator Delete Assembly** should be pointing down slightly, NOT pointing up. Transfer marks from the end of the **Resonator Delete Assembly** to the OEM Catback.

**Refer to Figure 2.**

3. Measure 2.5" forward toward the front of the car from the marks made in step 2 and scribe a cut line on the OEM pipes. Using a sawsall or similar tool, cut and deburr the OEM pipes.

**Refer to Figure 3.**

4. Install a **2.75" Clamp** onto each outlet of the **Resonator Delete Assembly** before connecting it to the section of cat back exhaust remaining on the vehicle.

5. Reusing the original clamps, connect the **Resonator Delete Assembly** to the front pipes. Ensure the assembly is installed level as viewed from the rear and tighten all clamps.

**Refer to Figure 4.**

6. Check along the whole length of the exhaust system to ensure that there is adequate clearance around fuel and brake lines or any other components. If any interference is detected relocate or adjust.

Congratulations! You are ready to begin experiencing the improved performance and driving pleasure of your **MBRP** performance exhaust system. We know you will enjoy your purchase.