



CONTROL IS EVERYTHING

MSS Install Guide

Supplied for the MINI Cooper (F55/56/57)





R5 MSS Ltd
 MSS House
 A3 Albion Daedalus Park
 Daedalus Drive
 Lee On The Solent
 Gosport
 Hampshire
 PO13 9FX
 United Kingdom
 Company No. 09360144
 mss.company

Introduction

This short guide is intended for use with the MSS Kit MINI Cooper (F55/56/57)

Pre-install steps

Refer to pages 3 and 4 of the latest version of the 'MSS INFO for Installer' or email support@mss.company for the latest copy, to measure the current ride height.

Front Axle Install Parts List

Before you start installing your new MSS Kit, check if all parts listed below have been supplied

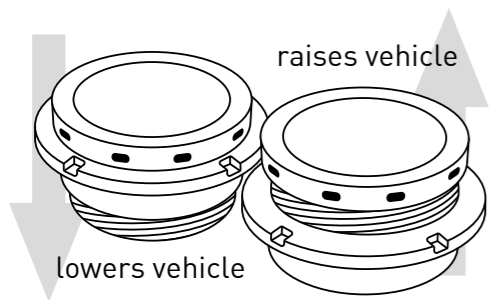

2x Large adjusters - these are the larger of the 2 sets

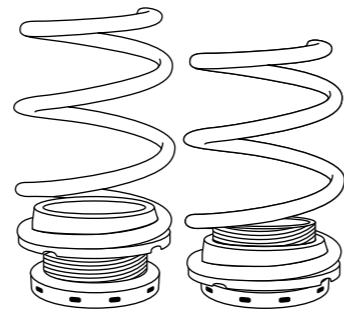

2x Large diameter MSS orange springs 220-3 these fit the larger adjusters

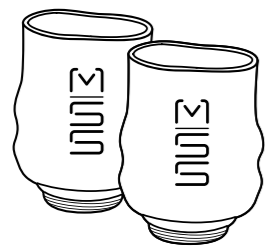

2x OPTIONAL Large protective sleeves around the large adjusters



2x MSS Supplied PU seats



2x MSS Supplied bump stops



R5 MSS Ltd
 MSS House
 A3 Albion Daedalus Park
 Daedalus Drive
 Lee On The Solent
 Gosport
 Hampshire
 PO13 9FX
 United Kingdom
 Company No. 09360144
 mss.company



FRONT AXLE INSTALL PROCEDURE

This is best done with struts removed from the vehicle. Refer to the manufacturer's workshop manual for steps on how to safely remove the struts from the vehicle, remove and refit the springs and on the correct torque settings.

Difficulty level: High ~~~~

Estimated Time: 90 to 120 minutes per side, assuming the bolts are not seized.

Installing your new MSS Kit is best undertaken by an experienced BMW/Mini workshop/engineer.

1. Remove the OE springs. These will be replaced by the MSS front system supplied.
2. Remove the OE rubber dust boots. Keep these as they will be reused.
3. Remove and replace the OE bump stops with the MSS Supplied bump stops.
4. Remove and retain the O.E bump caps. These will be reused.
5. Remove the bottom O.E rubber spring mount and replace with black MSS PU seat.
6. Fit the retained OEM plastic bump stop cap that protects the strut seal. Sit the adjuster on the PU seat.
7. OPTIONAL: Fit the MSS protective sleeves over the adjuster for dust protection.
8. Fit the grounded face of the MSS large spring MSS 220-3 flush to the adjuster seat and keep together.
9. Now fit the protective rubber boot over the strut shaft to protect it from debris, re-insert the OE bump stop.
10. Fit the camberplate.
11. Use a spring compressor to reduce spring height and help secure the arrangement.
12. Tighten to the correct torque with appropriate tools used to remove the camberplate.
13. Set the adjuster to the desired position; you can always re-adjust as required.

POST INSTALL STEPS

Complete a 1-mile journey before setting the ride height and 4-wheel alignment.

Refer to pages 3 and 4 of the latest version of the 'MSS INFO for Installer' guide for assistance on how to measure ride height.

The rear axle ride height should be set to at least 5mm higher than the front axle ride height when measured as per page 3 of the latest version of the



What if a part is missing? Please email support@mss.company. We will resolve the issue as quickly as we can.



R5 MSS Ltd
 MSS House
 A3 Albion Daedalus Park
 Daedalus Drive
 Lee On The Solent
 Gosport
 Hampshire
 PO13 9FX
 United Kingdom
 Company No. 09360144
 mss.company

Rear Axle Install Parts List

Before you start installing your new MSS Kit, check if all parts listed below have been supplied:

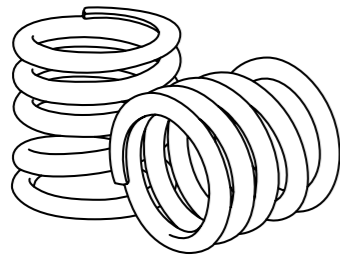

2x Black MSS springs - these are common parts used for almost all our products

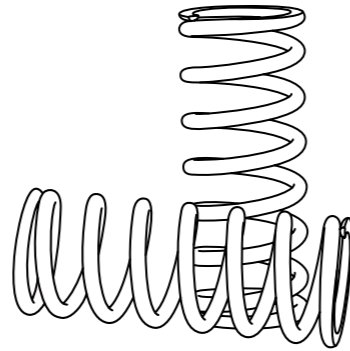

2x Small diameter MSS orange springs MSS 100-1

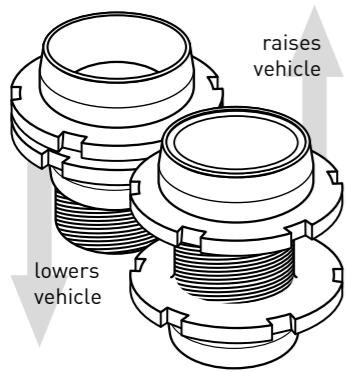

2x Combined adjusters - to couple the black and orange springs together and adjust height

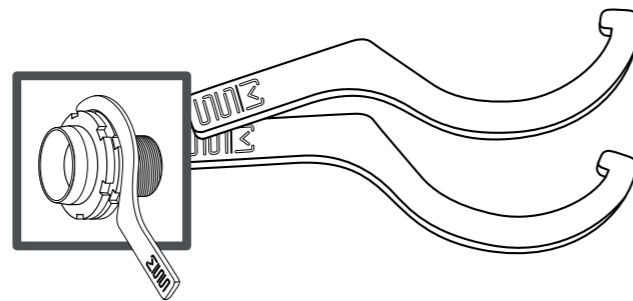

2x Adjuster spanners - for both front and rear adjusters

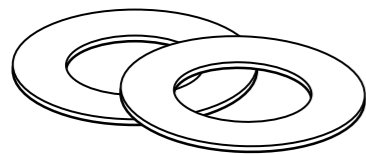

2x MSS supplied flat rubber slip mats - to eliminate resonant road noise travelling through the system

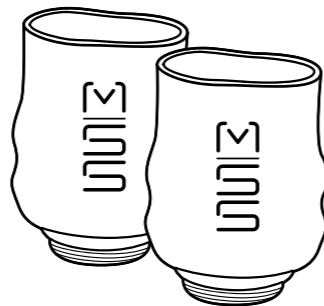

2x OPTIONAL Small protective sleeves - these fit around the combined adjusters



R5 MSS Ltd
 MSS House
 A3 Albion Daedalus Park
 Daedalus Drive
 Lee On The Solent
 Gosport
 Hampshire
 PO13 9FX
 United Kingdom
 Company No. 09360144
 mss.company



REAR AXLE INSTALL PROCEDURE

For the rear stacked arrangement, refer to the latest version of the 'MSS INFO for Installer' guide or email support@mss.company for the latest copy.

Difficulty level: Medium

Estimated Time: 30 to 45 minutes per side, assuming the bolts are not ceased.

Installing your new MSS Kit is best undertaken by an experienced BMW/Mini workshop/engineer.

1. Remove and retain the upper OE rubber spring seat, this will be reused.
2. Remove the lower OE seats and replace them with the MSS supplied rubber slip mats.
3. Couple the black & orange springs (MSS 100-1 with our patent-pending middle located rear adjuster). Ensure the Spring system is centralised at the top & bottom.
4. OPTIONAL: Fit the MSS protective sleeves over the adjuster for dust protection.
5. Fit the MSS stacked arrangement back in place of the OE single form spring. Our stacked springs are a direct replacement for the factory single form springs.
6. Tighten the suspension parts that had been removed. Refer to the manufacturer's workshop manual for steps on how to safely remove the struts from the vehicle, remove and refit the springs and on the correct torque settings.
7. Set the ride height to sit 5mm higher than the fronts when measured from fender edge to wheel hub centre.



Please be aware that this is a MUST DO.

POST INSTALL STEPS

Complete a 1-mile journey before setting the ride height and 4-wheel alignment. Refer to pages 3 and 4 of the latest version of the 'MSS INFO for Installer' guide for assistance on how to measure ride height.



The rear axle ride height should be set to at least 5mm higher than the front axle ride height when measured as per page 3 of the latest version of the

'MSS INFO for Installer' guide. This is a KEY step.



CONTROL IS
EVERYTHING

Triple Engineered Suspension for Ultimate Performance, Comfort & Safety

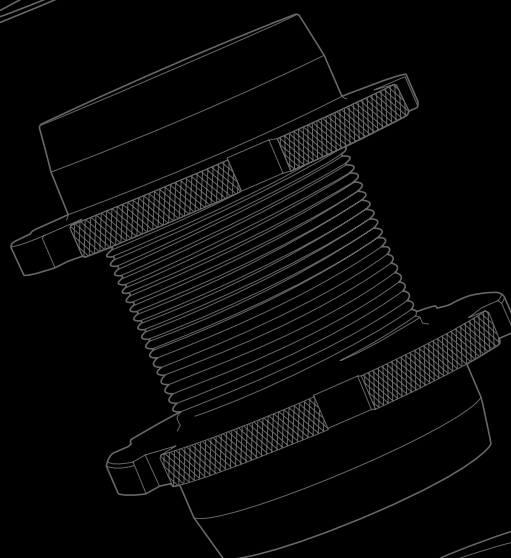

MSS Support Team

Telephone: +44 (0)20 3507 1973

(select appropriate option when prompted)

Email: support@mss.company