



CONTROL IS  
EVERYTHING

---

# MSS Install Guide

Supplied for the Mercedes C-Class 2014 onwards





R5 MSS Ltd  
MSS House  
A3 Albion Daedalus Park  
Daedalus Drive  
Lee On The Solent  
Gosport  
Hampshire  
PO13 9FX  
United Kingdom  
Company No. 09360144  
mss.company

## Introduction

This short guide is intended for use with MSS Kit for the **Mercedes C-Class 2014 to present** (all variants up to the AMG range).

## Pre-install steps

Refer to pages 3 and 4 of the latest version of the 'MSS INFO for Installer' or email [support@mss.company](mailto:support@mss.company) for the latest copy, to measure the current ride height.

## Front Axle Install Parts List

Before you start installing your new MSS Kit, check if all parts listed below have been supplied:

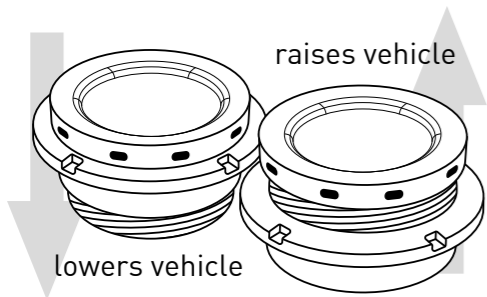

**2x** Large adjusters - these are the larger of the 2 sets

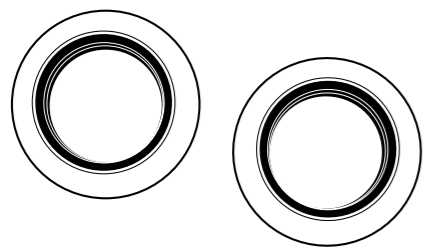

**2x** MSS supplied OE bearing parts - these must replace the ones removed

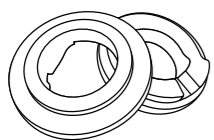

**2x** MSS polyurethane (PU) hard rubber seats

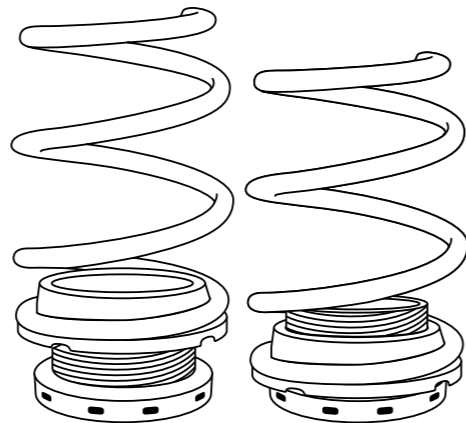

**2x** Large diameter MSS orange springs - these fit the larger adjusters (Shown)

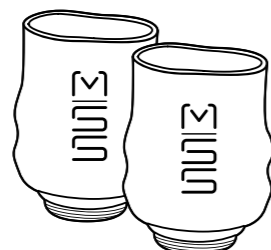

**2** OPTIONAL Large protective sleeves - these fit around the large adjusters

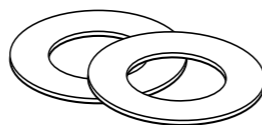

**2** MSS supplied Large flat rubber slip mats to eliminate resonant road noise travelling through the system



R5 MSS Ltd  
MSS House  
A3 Albion Daedalus Park  
Daedalus Drive  
Lee On The Solent  
Gosport  
Hampshire  
PO13 9FX  
United Kingdom  
Company No. 09360144  
mss.company



## FRONT AXLE INSTALL PROCEDURE

This is best done with struts removed from the vehicle. Refer to the manufacturer's workshop manual for steps on how to safely remove the struts from the vehicle, remove and refit the springs and on the correct torque settings.

Difficulty level: High ~~~~

Estimated Time: 60 to 90 minutes per side, assuming the bolts are not seized.

Installing your new MSS Kit is best undertaken by an experienced Mercedes Benz workshop/engineer.

1. Remove the OE springs. These will be replaced by the MSS front system supplied.
2. Remove and keep the OE rubber dust boots. These will be re-used.
3. Keep the OE bump stop to re-use.
4. Fit the MSS PU rubber seat over the strut to fit snugly with the perch based stepped seat.
5. Fit the OE bearing over the strut to sit flush to the MSS PU rubber seat at the base of the perch.
6. Ensure that the steel part is facing upwards to fit the MSS large adjuster.
7. Now fit the MSS supplied large rubber mat on top of the bearing and then place the MSS large adjuster to sit on top to the rubber mat & bearing
8. Fit the MSS protective sleeve over the adjuster and bearing for protection from dust.
9. Fit the OE rubber dust boots over the strut shaft to protect it from debris.
10. Next, fit the large MSS orange spring.
11. Fit the camberplate to the MSS spring and turn the MSS adjuster to take up any free play.
12. Secure the arrangement with the nut at the top of the camberplate.
13. Tighten to the correct torque with appropriate tools used to remove the camberplate.
14. Set the adjuster to the desired position. Later, you can always re-adjust as required.

**NOTE:** The large adjuster sits at the bottom of the strut for easier access to adjustment.



R5 MSS Ltd  
 MSS House  
 A3 Albion Daedalus Park  
 Daedalus Drive  
 Lee On The Solent  
 Gosport  
 Hampshire  
 PO13 9FX  
 United Kingdom  
 Company No. 09360144  
 mss.company



R5 MSS Ltd  
 MSS House  
 A3 Albion Daedalus Park  
 Daedalus Drive  
 Lee On The Solent  
 Gosport  
 Hampshire  
 PO13 9FX  
 United Kingdom  
 Company No. 09360144  
 mss.company

## Rear Axle Install Parts List

Before you start installing your new MSS Kit, check if all parts listed below have been supplied:

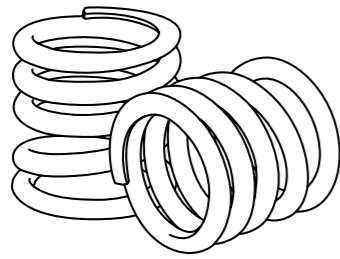

- 2x** Black MSS springs - these are common parts used for almost all our products

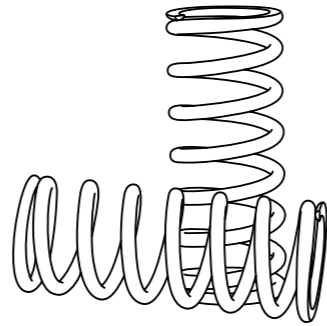

- 2x** Small diameter MSS orange springs

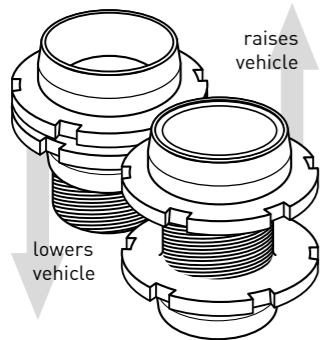

- 2x** Combined adjusters - used to couple the black and orange springs

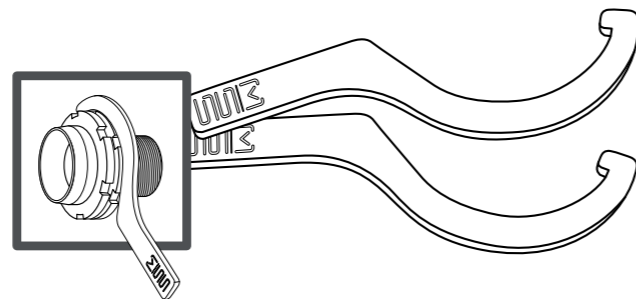

- 2x** Adjuster spanners - for both front and rear adjusters

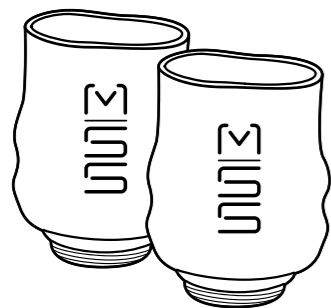

- 2x** OPTIONAL Small protective sleeves - these fit around the combined adjusters



## REAR AXLE INSTALL PROCEDURE

For the rear stacked arrangement, refer to the latest version of the 'MSS INFO for Installer' guide or email [support@mss.company](mailto:support@mss.company) for the latest copy.

Difficulty level: Medium

Estimated Time: 60 to 90 minutes per side, assuming the bolts are not ceased.

Installing your new MSS Kit is best undertaken by an experienced Mercedes Benz workshop/engineer.

1. Remove the OE springs.
2. Separate the top mounted spring seat, which is formed of a plastic base plate and a rubber seat.
3. Retain the plastic base plate and re-fit that back on the vehicle. The base plate centralises the orange spring when fitted.
4. Fit the MSS protective sleeves over the adjuster for protection from dust.
5. Fit the MSS stacked arrangement back in place for the OE single form spring. Our stacked springs are a direct replacement for the factory single form springs. Therefore, no other OE parts are replaced during the rear axle install.
6. Tighten the suspension parts that had been removed. Refer to the manufacturer's workshop manual for steps on how to safely remove the struts from the vehicle, remove and refit the springs and on the correct torque settings.
7. Set the ride height to sit 5mm higher than the fronts when measured from fender edge to wheel hub centre.



**Please be aware that this is a MUST DO.**



### Additional info -

Assembled parts prior to fitting to the vehicle



Front strut perch base fit



Rear stacked arrangement

## POST INSTALL STEPS

Complete a 1-mile journey before setting the ride height and 4-wheel alignment. Refer to pages 3 and 4 of the latest version of the 'MSS INFO for Installer' guide for assistance on how to measure ride height.



The rear axle ride height should be set to at least 5mm higher than the front axle ride height when measured as per page 3 of the latest version of the 'MSS INFO for Installer' guide. **This is a KEY step.**

What if a part is missing? Please email [support@mss.company](mailto:support@mss.company). We will resolve the issue as quickly as we can.



CONTROL IS  
EVERYTHING

# Triple Engineered Suspension for Ultimate Performance, Comfort & Safety

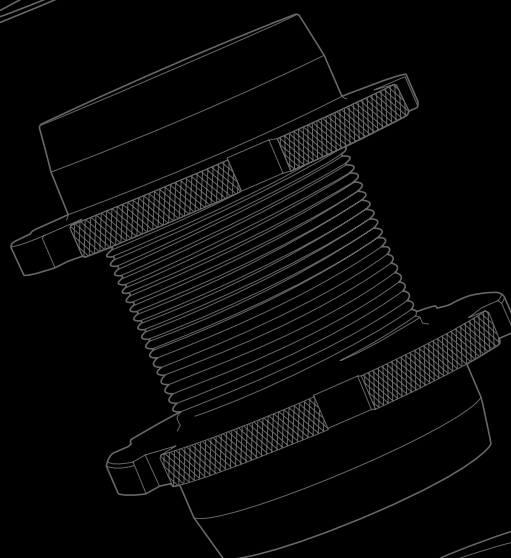

**MSS Support Team**

**Telephone:** +44 (0)20 3507 1973

(select appropriate option when prompted)

**Email:** [support@mss.company](mailto:support@mss.company)