

# CO2 POWER TANK MOUNTING BRACKET

## Hardware Kit Includes:

- (1) 4 – Button Head Socket Cap Bolts (M8-1.25 x 25mm)
- (2) 4 – Lock washers (M8)
- (3) 8 – Flat Washers (M8)
- (4) 4 – Hex Head Nuts (M8-1.25)

## Components List:

- (1) 1 – CO2 Mount Part A (100054)
- (2) 1 – CO2 Mount Part B (100055)
- (3) 1 – 1/2" Pin
- (4) 1 – 9/16" Pin

**LOOSE FIT ALL COMPONENTS.  
DO NOT TIGHTEN UNTIL ALL  
COMPONENTS ARE INSTALLED  
AND ADJUSTED.**

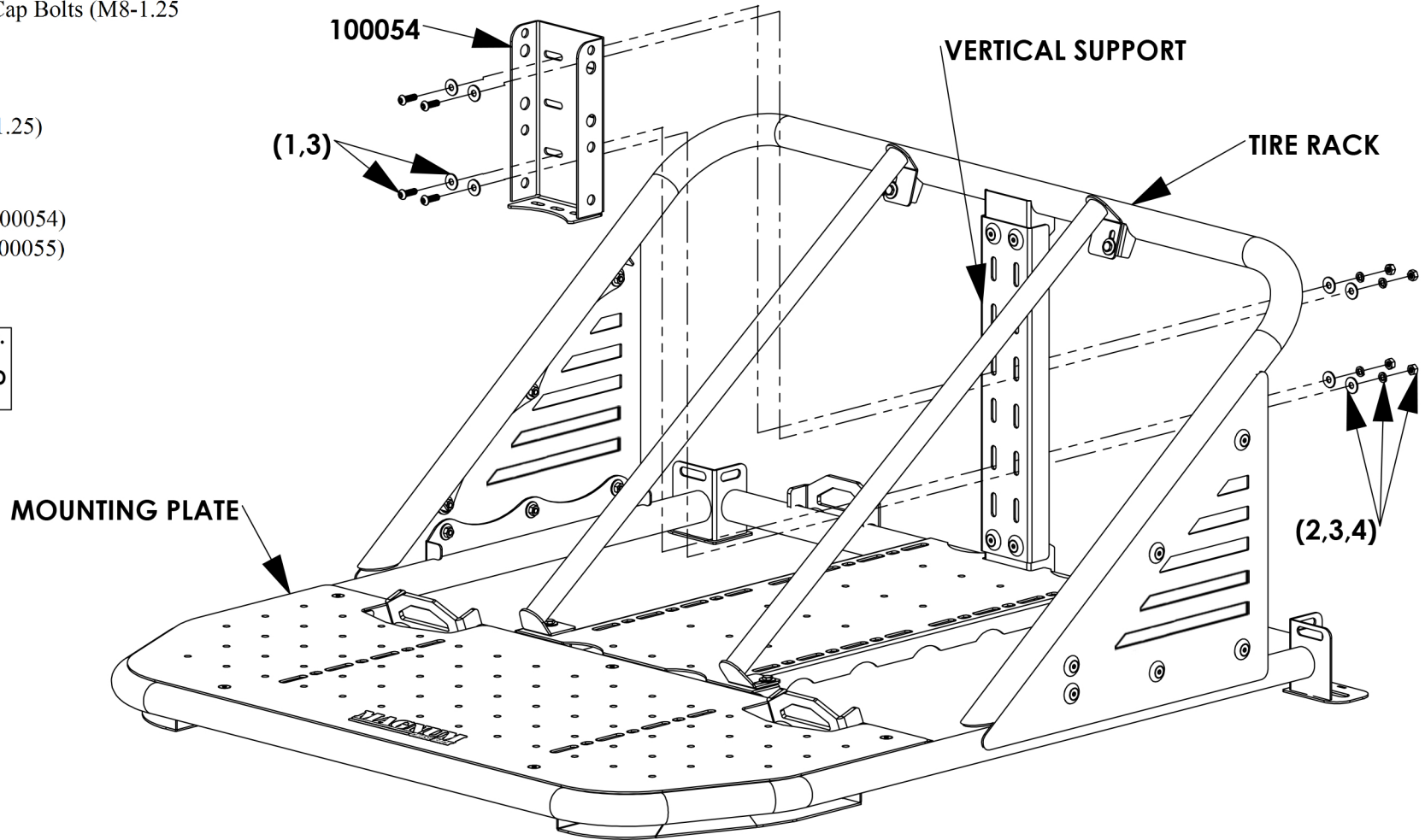

## Step-By-Step Installation Instructions:

- (1) Start by selecting the mounting location for the CO2 Mount Part A (100054). Be sure that the mounting location of the CO2 Mount will not interfere with other components on the tire rack.
- (2) If you choose to mount the CO2 mount standing upright on the mounting plate or center tray of the tire rack, use two of the three mounting holes on the bottom edge of the bracket. Use two M8 button head bolts, lock washers, and hex nuts with four flat washers to mount the bracket.

**NOTE: If mounting to the mounting plate, the mounting plate must be taken off so that the hardware for the CO2 Mount can be tightened on the bottom.**

- (3) If you choose to mount the CO2 Mount to the vertical support of the tire rack, use four M8 button head bolts, flat washers, lock washers, and hex nuts. Mount the bracket 100054 to the vertical support loosely. Adjust the height before tightening all hardware.

# CO2 POWER TANK MOUNTING BRACKET

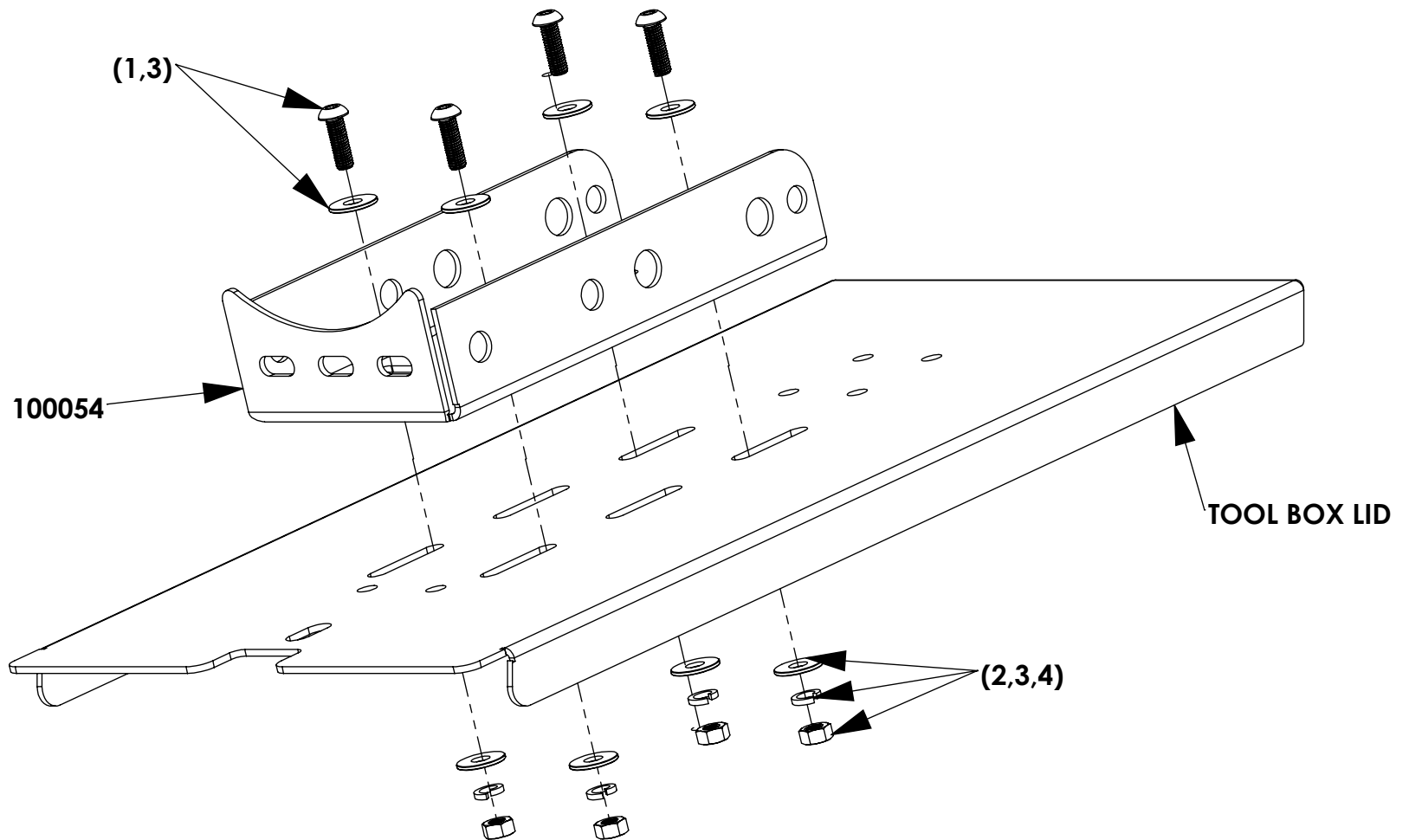

LOOSE FIT ALL COMPONENTS.  
DO NOT TIGHTEN UNTIL ALL  
COMPONENTS ARE INSTALLED  
AND ADJUSTED.

## Step-By-Step Installation Instruction for Mounting to Tool Box Lid:

- (1) Begin by placing the CO2 Mount Part A (100054) on the lid of the tool box.
- (2) Loosely fasten the mount to the lid using the provided M8 hardware.
- (3) Make any adjustment to the mount and tighten the hardware.

# CO2 POWER TANK MOUNTING BRACKET

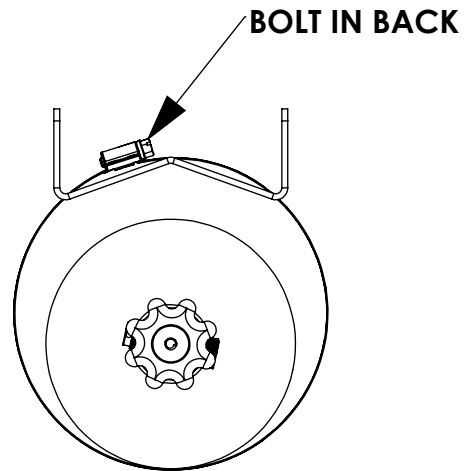
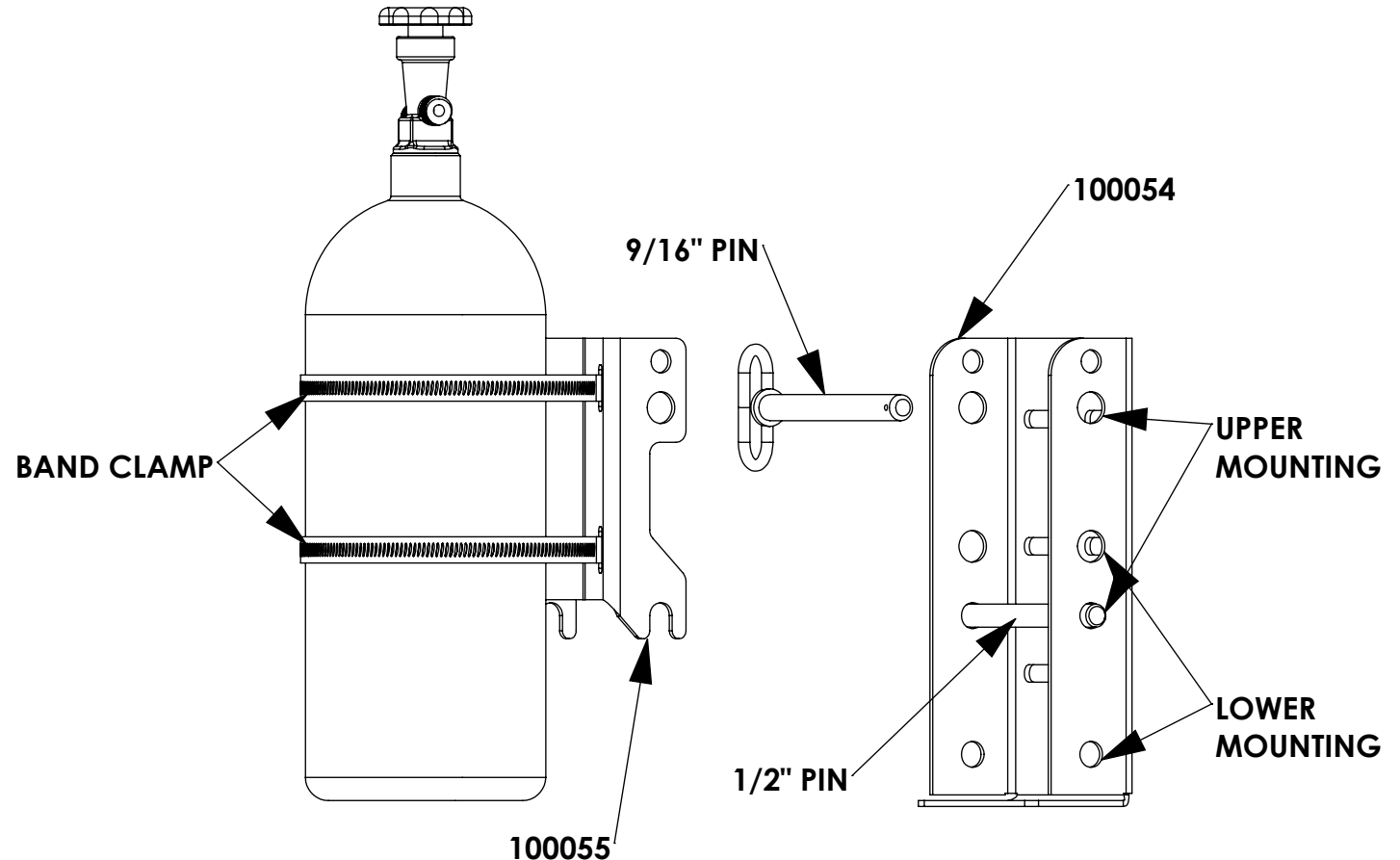

FIG A

LOOSE FIT ALL COMPONENTS.  
DO NOT TIGHTEN UNTIL ALL  
COMPONENTS ARE INSTALLED  
AND ADJUSTED.



## Step-By-Step Installation of the CO2 Bottle:

- (1) Begin by running the two band clamps through the slots in the CO2 Mount Part B (100055). Be sure that the bolt on the band clamp is located in the back of the bracket as shown in Figure A. Start the band clamp onto the threads so that it does not fall off.
- (2) Slide the CO2 Mount Part B with band clamps over the CO2 bottle.
- (3) Position the CO2 bottle next to CO2 Mount Part A (100054) so that the height of the band clamps on the bottle can be determined and the band clamps can be tightened.

**NOTE: Pay attention to whether the height is based on the upper mounting or lower mounting holes in 100054.**

- (4) Place the 1/2\" Pin in the bottom hole the mounting location chosen in 100054. Lock the pin in place with a retainer pin.
- (5) Slide the open slot on the bottom of 100055 over the 1/2\" pin.
- (6) Lock the CO2 tank in place using the 9/16\" pin, passing it through the upper mounting hole.

**NOTE: The extra hole at the top of the CO2 Mount is for a padlock to prevent theft.**