

Heavy Duty Winch Front Bumper

2018 Jeep Wrangler JL Full Length Front Bumper With Winch

FBM36JPN
03/13/18
Page. 1

BUMPER HARWARE KIT INCLUDES:

- (1) 6 – M8-1.25 Hex Head Nuts
- (2) 8 – M8 Flat Washers
- (3) 6 – M8 Lock Washers
- (4) 2 – M8-1.25 x 30MM Hex Head Bolts
- (5) 8 – M10-1.50 Hex Head Nuts
- (6) 8 – M10 Flat Washers
- (7) 8 – M10 Lock Washers
- (8) 8 – M10 Plastic Push Nuts
- (9) 8 – 3/8"-16 x 1" SS Button Head Bolts
- (10) 10 – 3/8" SS Flat Washers
- (11) 2 – 3/8" Lock Washers
- (12) 2 – 3/8"-16 Hex Head Nuts
- (13) 8 – M6-1.00 x 20mm Hex Head Bolts
- (14) 8 – M6-1.00 Hex Head Nuts
- (15) 8 – M6 Lock Washers

COMPONENTS LIST:

- (1) 1 – Magnum Plate Bumper (FBM36JPN)
- (2) 2 – M8 T-Bolts (BP5883)
- (3) 4 – M10 T-Bolts (BP5886)
- (4) 1 – Skid Plate (BP5854)
- (5) 2 – Skid Plate Mounting Tab (BP5860)
- (6) 2 – OE Fog Light Adapter Bracket (BP5882)
- (7) 2 – Skid Plate Mount Tab 2 (BP5905)
- (8) 2 – OE Fog Light Adapter Bracket 2 (BP5998)

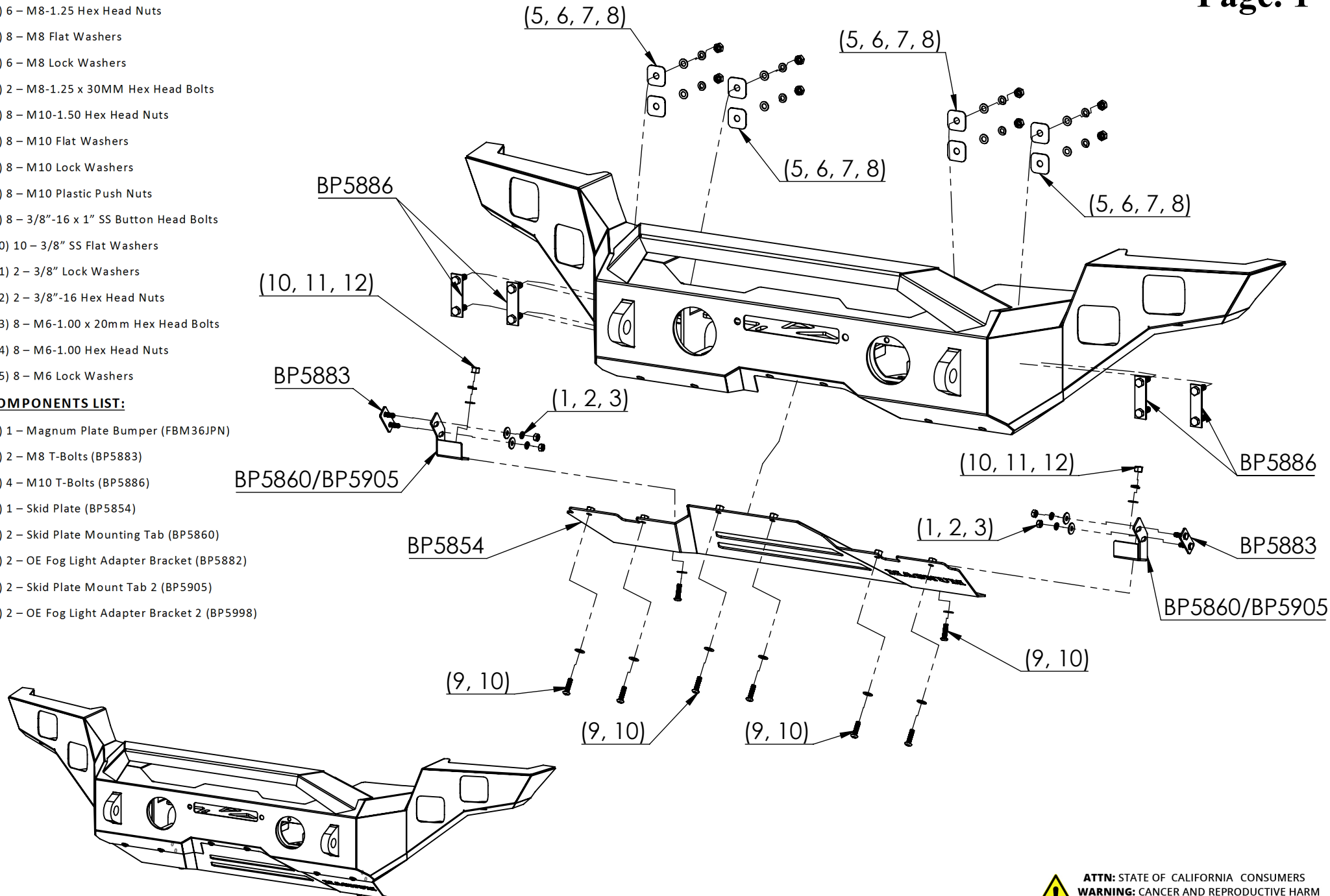

Heavy Duty Winch Front Bumper

2018 Jeep Wrangler JL Full Length Front Bumper With Winch

FBM36JPN

03/13/18

Page. 2

FIG. A

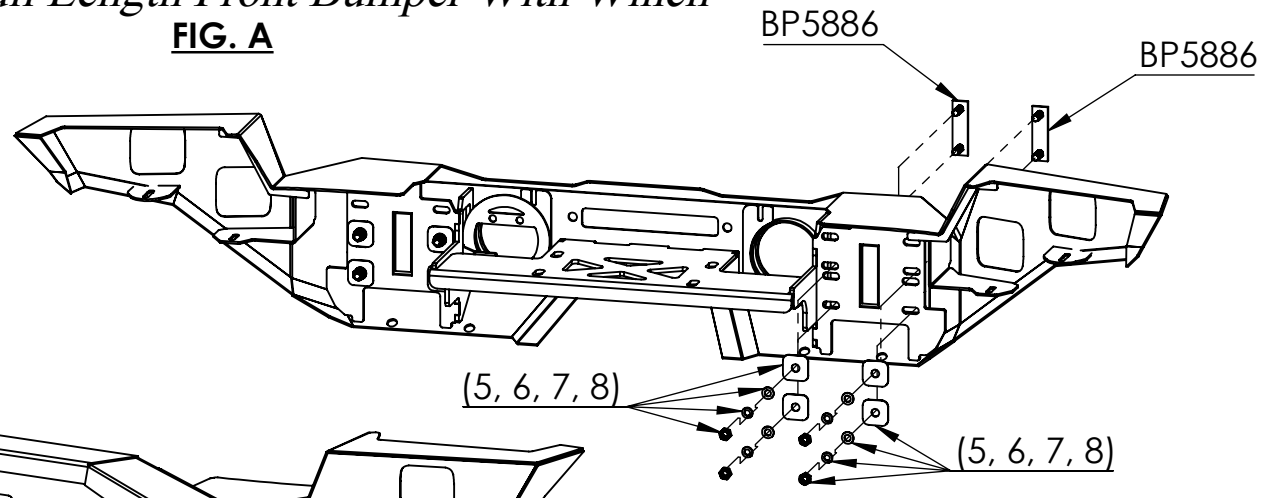

FIG. B

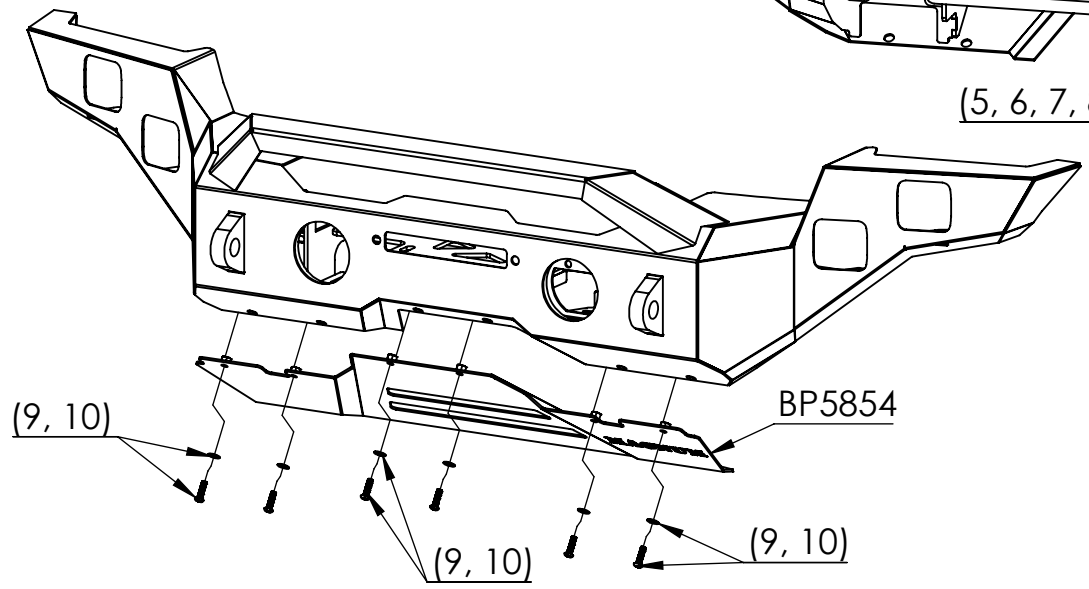

FIG. D

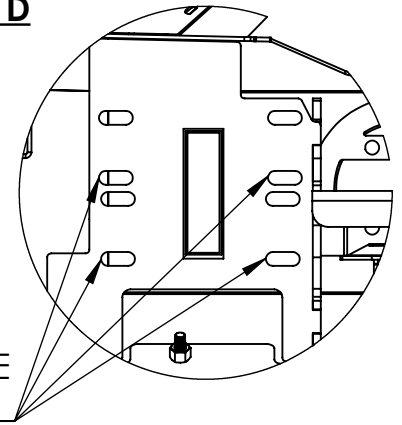
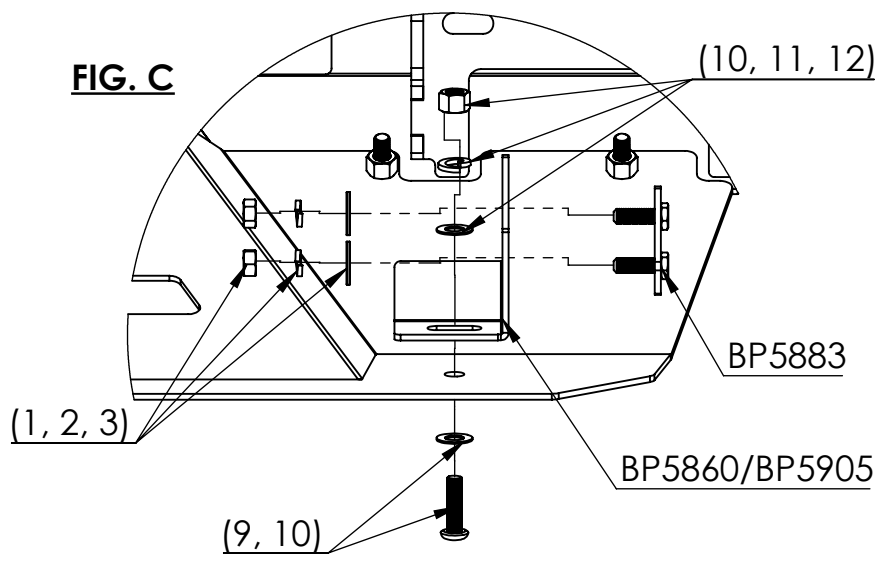

FIG. C



NOTE:

IF YOUR JEEP IS EQUIPPED WITH THE LOWLINE FENDERS, YOU WILL NEED TO USE THE OTHER SET OF MOUNTING HOLES TO ENSURE BUMPER CLEARS FENDERS.

Heavy Duty Winch Front Bumper

2018 Jeep Wrangler JL Full Length Front Bumper With Winch

FBM36JPN
03/13/18
Page. 3

Step by Step Installation:

1. Start by unplugging factory wiring harness on front bumper (Located on outside face of passenger side frame rail.)
2. Remove (2) plastic push pins from plastic filler panel on top of frame rails.
3. Remove (2) bolts attaching skid plate to the frame, now remove (6) plastic push pins attaching skid plate to the front bumper assembly.
4. Remove (8) bolts attaching bumper assembly to the frame, there are (4) per side. Carefully remove bumper from vehicle and set to the side.
5. Remove (12) plastic push pins from the front bumper assembly to access to OEM fog lights; there are (6) per side. Remove the OEM Fog lights to install into the Magnum Bumper. Start by removing (8) bolts retaining the lights to the factory bumper, there are (4) per light. Once unbolted remove from harness and set aside.
6. With lights removed you will need to remove the wiring harness from the factory bumper assembly. To do this you will need to remove the internal components from the outside shell of the bumper and unclip the harness from the bumper.
7. Take OEM fog lights and attach them to the magnum bumper using provided M6 Hardware. If you have the molded plastic OEM front bumper, you will use (BP5882) fog light adapter brackets with the provided M6 hardware (you will need to drill the holes on light housing to fit the M6 bolts.) Once attached to bracket you will attach bracket to tab on bumper using provided (2) M8 bolts, hex nuts, lock washers and (4) flat washers.

If you have the steel OEM front bumper you will attach the fog lights directly to the bumper using the provided M6 hardware.
8. Attach provided T-bolts (BP5886) to Magnum bumper with M10 plastic push nuts. (See Page 2; FIG. D, for Mounting Locations, they may vary depending on fenders installed from factory.) With help, lift and align bumper to the frame and attach using provided (8) M10 flat washers, lock washers, hex nuts; there are (4) per side. Adjust bumper and snugly fasten hardware to the frame. (See FIG. A; Page 2)
9. Reattach factory wiring harness to the OEM fog lights and secure the harness to the bumper as needed, once secured attach harness to plug on passenger side of frame.
10. ICI recommends attaching winch options prior to installation of skid plate to allow for easier access to mounting locations to securely fasten winch to bumper. Install using Manufacturers guidelines.
11. Once all winch options are installed, attach Skid Plate (BP5854) to bumper using the provided (6) 3/8" Stainless button head bolts, flat washers; loosely fasten. (See FIG. B; Page 2)
12. Once Skid Plate (BP5854) has been aligned, attach the Skid Plate Mounting Tabs (BP5860) to the frame using provided (2) M8 T-bolts (BP5883) and (4) M8 flat washers, lock washers, and hex nuts. Attach Skid Plate Mounting Tabs (BP5860) to Skid Plate (BP5854) using remaining 3/8" stainless hardware. (If you have the lowline fenders you will use BP5905 instead of BP5860 to adjust for bumper height difference. Tightly fasten all hardware to skid plate and skid plate mounting tabs. (See FIG. C; Page 2)

Heavy Duty Winch Front Bumper

2018 Jeep Wrangler JL Front Bumper With Winch

FBM22/36JPN

07/27/18

PAGE 1

THE 2018 JEEP WRANGLER JL IS EQUIPPED WITH 3 VARIATIONS OF OEM LIGHTING OPTIONS.

OPTION A - USES MOUNTING OPTION SHOWN IN FIG. A USING VERTICAL SLOTS ON WELDED IN BRACKET.

OPTION B - USES MOUNTING OPTION SHOWN IN FIG. B USING SUPPLIED BP5882, ATTACHING TO THE TAB THAT IS ON WELDED IN BRACKET.

OPTION C - USES MOUNTING OPTION SHOWN IN FIG. C USING SUPPLIED BP5998, ATTACHING TO THE TAB THAT IS ON WELDED IN BRACKET.

FIG. A

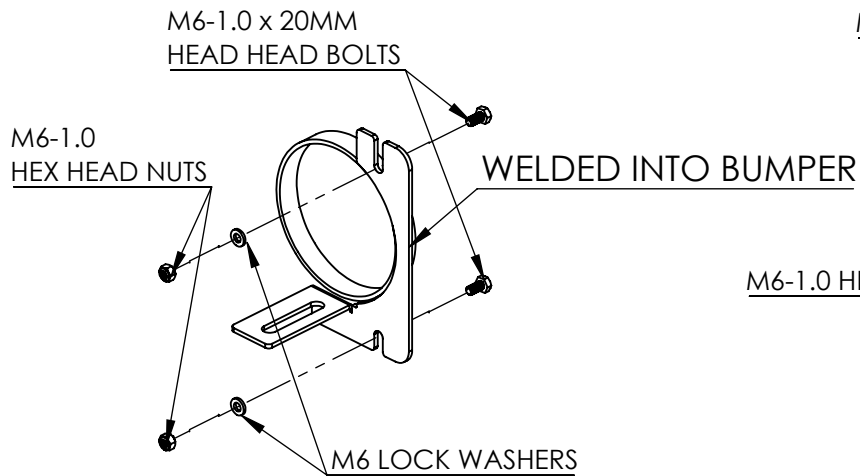

IF JL IS EQUIPPED WITH STEEL OEM BUMPER AND HAS THE VERTICAL STYLE OEM FOG LIGHT YOU WILL MOUNT FOG LIGHTS USING METHOD SHOWN IN FIG. A

FIG. B

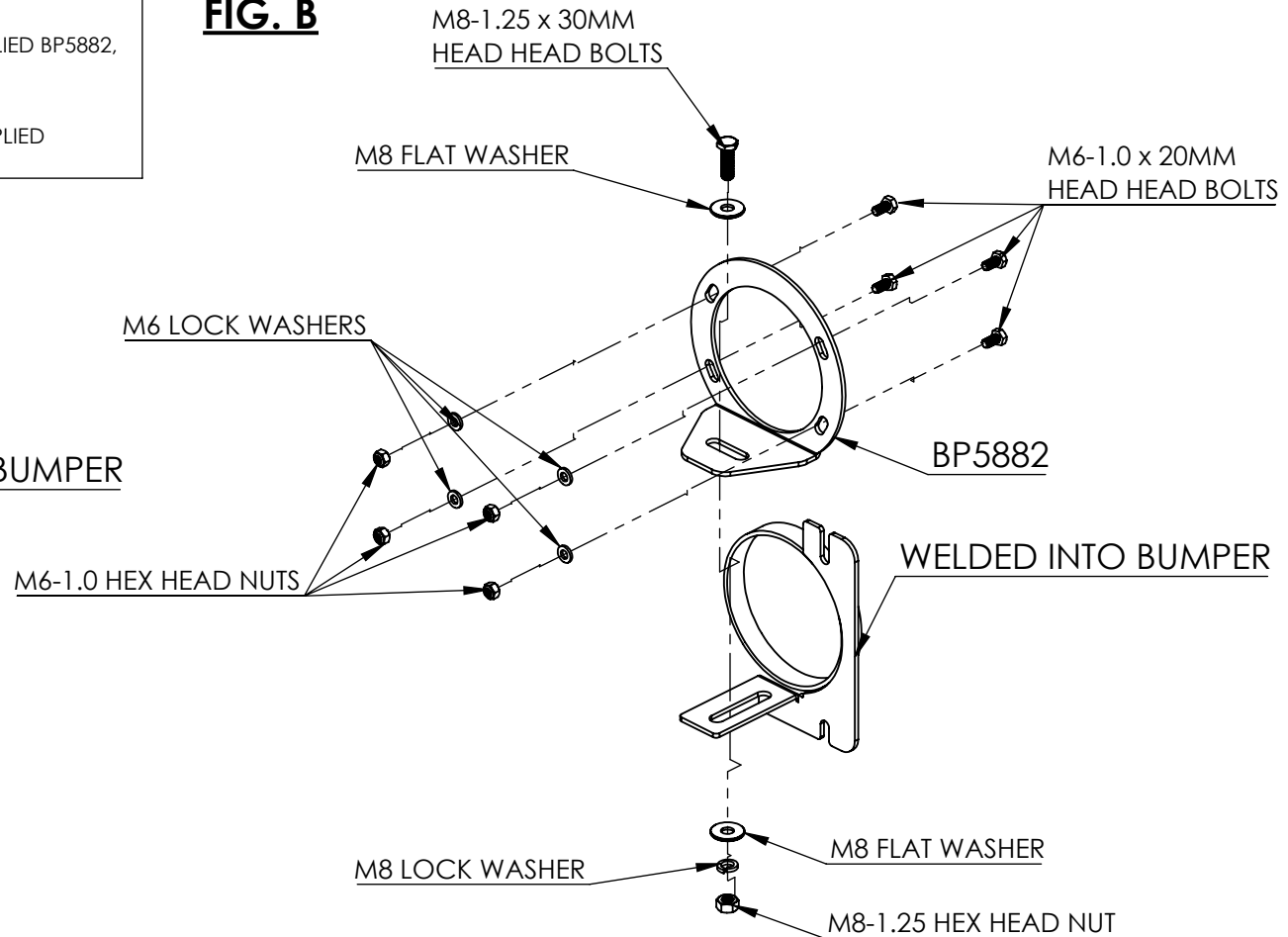

IF JL IS EQUIPPED WITH PLASTIC OEM BUMPER AND HAS THE JK STYLE OEM FOG LIGHT YOU WILL MOUNT FOG LIGHTS USING METHOD SHOWN IN FIG. B

Heavy Duty Winch Front Bumper

2018 Jeep Wrangler JL Front Bumper With Winch

FBM22/36JPN

07/27/18

PAGE 2

FIG. C



FIGURE C-1

OEM FOG LIGHT ASSEMBLY

TAKE OEM FOG LIGHT ASSEMBLY FROM FACTORY BUMPER (SHOWN IN FIGURE C-1)



FIGURE C-2

(3) PINS ATTACHING FOG LIGHT TO HOUSING.

REMOVE OEM FOG LIGHT FROM FACTORY HOUSING BY COMPRESSING FLANGES ON PINS HOLDING THEM TOGETHER.

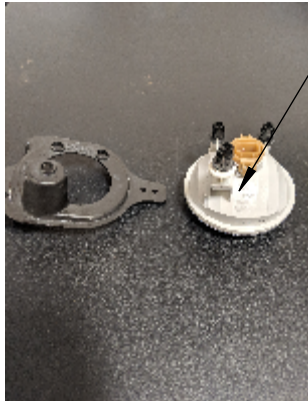

FIGURE C-3

OEM FOG LIGHT

FOG LIGHT SHOULD RETAIN THE BLACK PINS TO REINSTALL INTO (BP5998 - FOG LIGHT ADAPTER BRACKET.)

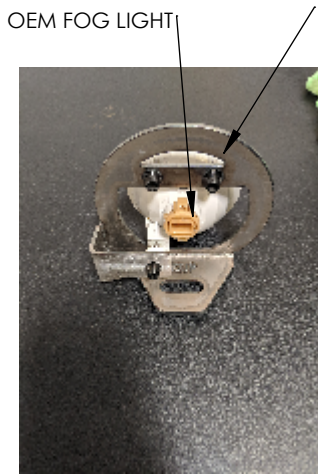

FIGURE C-4

OEM FOG LIGHT

BP5998 - OEM FOG LIGHT ADAPTER BRACKET

FOG LIGHT SHOULD SNAP INTO BP5998 USING THE BLACK RETAINER PINS. IF LIGHT ASSEMBLY IS LOOSE, YOU MAY ADD 3/8" FLAT WASHERS BETWEEN RETAINER PINS AND BP5998 TO REDUCE MOVEMENT.



FIGURE C-7

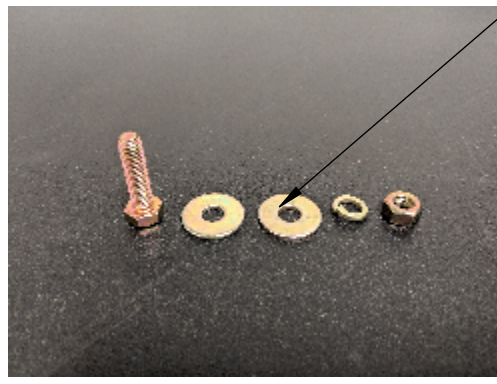

FIGURE C-5

SUPPLIED M8 MOUNTING HARDWARE

USE SUPPLIED M8 HARDWARE TO INSTALL LIGHT ASSEMBLY TO LIGHT MOUNTING TAB IN FBM22/36JPN (SHOWN IN FIGURE C-6)

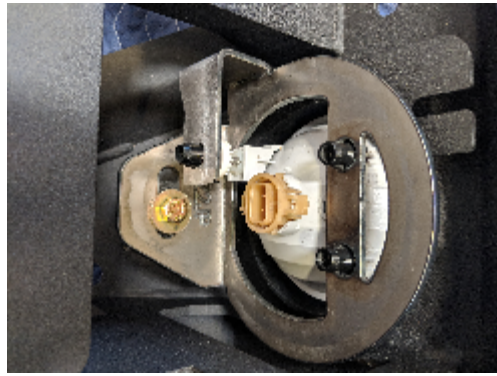

FIGURE C-6

ADJUST LIGHT ASSEMBLY SO THE FOG LIGHT LENS IS THE ONLY THING PROTRUDING FROM THE FRONT FACE OF BUMPER AND TIGHTEN M8 HARDWARE. (SHOWN IN FIGURE C-7)