



A4 ALUMINIUM STEP BAR

Part No. AL4004B



**Fits: 2007-2018 1500, 2007-2019 2500-3500
SILVERADO/SIERRA CREW CAB**



INCLUDES DIESEL W/DEF



REMOVE CONTENTS FROM BOX. VERIFY ALL PARTS ARE PRESENT.



READ INSTRUCTIONS CAREFULLY BEFORE STARTING INSTALLATION.

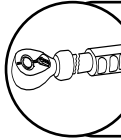

DO NOT OVER TORQUE. STANDARD OPERATING LOAD FOR TIGHTENING BODY MOUNT NUTS & BOLTS VARIES FROM 18 TO 20 FOOT POUND FOR M8 HARDWARE.



120 mins



Cutting Not Required



Drilling Not Required



support@trailfx.com



1- (866) 638 - 4870



POWDER COATED BLACK - LIMITED LIFETIME

PARTS LIST:

| Qty | Part Description | Qty | Part Description |
|-----|--|-----|----------------------------------|
| 2 | A4 Step Bar | 17 | 8mm x 25mm Hex Bolts |
| 7 | Mounting Brackets | 16 | 8mm T-Bolts |
| 1 | Passenger/Right Upper Mounting Bracket | 33 | 8mm x 24mm OD x 2mm Flat Washers |
| 1 | Passenger/Right Lower Mounting Bracket | 33 | 8mm Lock Washers |
| 8 | Plastic Covers | 16 | 8mm Hex Nuts |
| 16 | Plastic Clips | 15 | 8mm Clip Nuts |
| 1 | 8mm Bolt Plate | 1 | 8mm Nylon Lock Nut |

REPLACEMENT PARTS LIST (NOT INCLUDED IN BOX)

| | | | |
|---|--|---|-----------------------|
| 1 | Step Pad Pack (Includes clips) - G9029 | 1 | End Caps Pack - G9030 |
| 1 | Bracket Cover Pack - G9031 | | |

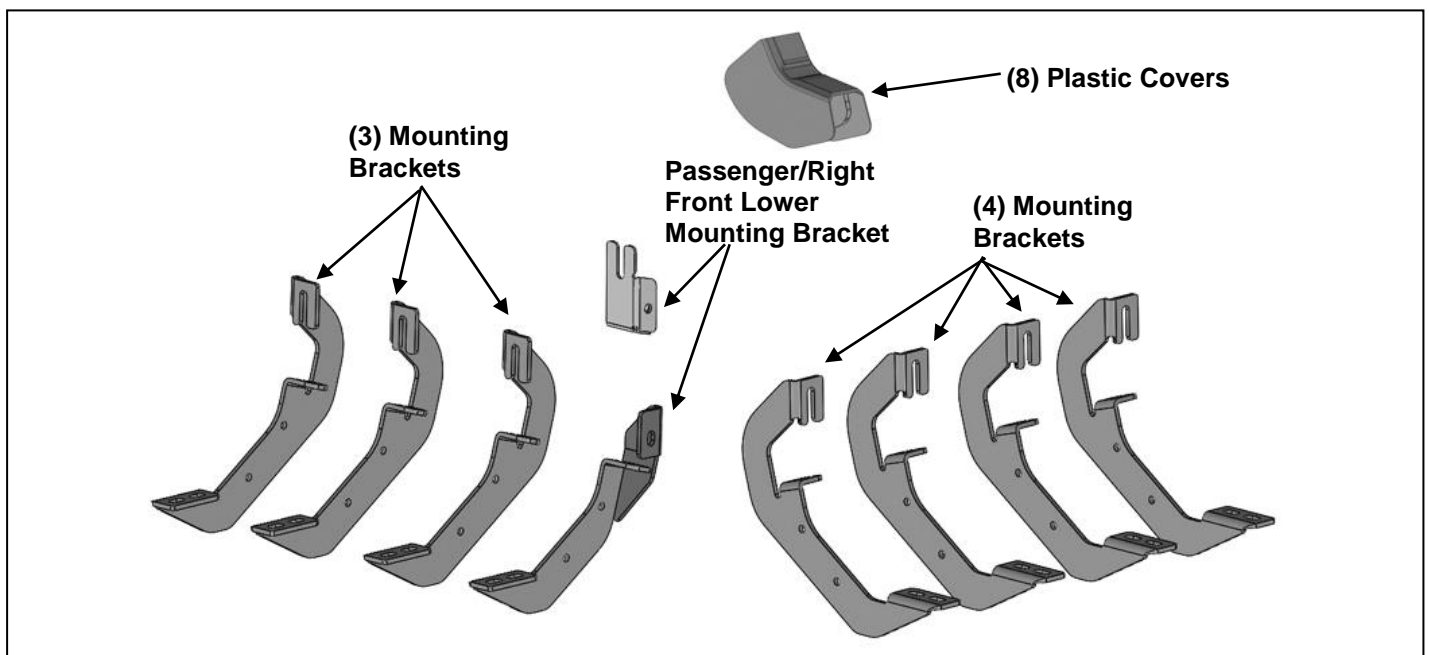

PROCEDURE:

REMOVE CONTENTS FROM BOX. VERIFY ALL PARTS ARE PRESENT. READ INSTRUCTIONS CAREFULLY BEFORE STARTING INSTALLATION. ON MODELS WITH DEF TANK, SELECT A FLAT, LEVEL AREA FOR INSTALLATION. MAY REQUIRE CUTTING.

1. Start the installation under the Driver/Left side of the vehicle. Locate the 5 tabs along the bottom edge of the body, (pinch weld). Mounting Brackets will bolt to the 1st, 3rd, 4th and 5th mounting tabs, **(Figure 1)**. Directly above each tab is a top mounting location on the side of the rocker panel. Hold a Bracket up in place to help determine the mounting holes to use.
2. Determine the correct procedure for your model year and each Bracket location.

Bottom mounting location on the edge of the pinch weld.**Flat tab on pinch weld with factory installed weld nut:**

Thread hex bolt into weld nut from the backside-down to clear paint from threads.

Flat tab on pinch weld with hole:

Select (1) 8mm Clip Nut. Slide the Clip Nut over the tab with the nut facing up behind the tab, **(Figures 2 & 3)**. Line up threaded nut with hole in the tab. Repeat for each mounting location.

Locate top mounting location on the back side of the rocker panel.**Models with factory installed threaded insert in rocker panel:**

Thread 8mm Hex Bolt into threaded insert to clear paint as required, **(Figures 2 & 3)**.

Large and small hole in side of body panel:

Remove the rubber plug from the larger hole, **(Figure 4)**. Select (1) 8mm Clip Nut. Slide the Clip Nut into the larger hole. Line up the threaded nut with the smaller hole.

3. Select (1) Mounting Bracket. Attach the Mounting Bracket to the Clip Nuts or the factory threaded holes with (2) 8mm Hex Bolts, (2) 8mm Lock Washers and (2) 8mm Flat Washers, **(Figure 5)**. Do not tighten hardware.
4. Select (1) Plastic Cover. Attach the Cover to the Mounting Bracket with (2) Plastic Clips, **(Figure 6)**.
5. Repeat **Steps 1—4** to attach (3) Mounting Brackets to the Driver/Left side.
6. Select (1) A4 Step Bar. Insert (8) T-Bolts into the channels in the bottom of the Sidebar, (4) per channel, **(Figure 7)**. Attach the Sidebar to the Mounting Brackets with (8) 8mm Flat Washers, (8) 8mm Lock Washers and (8) 8mm Hex Nuts, **(Figure 8)**. Do not tighten hardware
7. Move to the Passenger/Right side of the vehicle. Determine if the vehicle is equipped with a plastic diesel exhaust fluid (DEF) tank, **(Figures 9 & 10)**.

Models without DEF tank, skip to Step 8.

Models with DEF tank: The tank sits close to the side of the body. With specialized tools, the Passenger/Right Front Upper and Lower Mounting Brackets can be installed but room is very limited. Determine model year of vehicle before proceeding.

Up to 2016 models:

It may be easier to drop the tank down to access the inner side of the body panel for upper bracket installation. Tank will not need to be removed, only dropped down for access to mounting location.

IMPORTANT: If tank is full, it will be very heavy and assistance is highly recommended to avoid injury or damage to the vehicle or the tank. It is recommended that installation is performed when the DEF tank is low on fluid before dropping the tank.

- a. On models with plastic lower tray under the tank, remove the (3) hex bolts attaching the tray to the frame, **(Figure 9)**, and remove the tray.
- b. Release the tank filler hose. Release the plug for the sending unit on the top of the tank.
- c. Support the tank with a floor jack. Place a smooth flat surface, (wooden block for example), between the floor jack and the tank to avoid damaging the plastic tank. Do not push up on the tank; only support the weight of the tank with the jack.
- d. Remove the (2) bolts securing the tank straps to the vehicle, **(Figure 10)**. Tilt the straps to release from the brackets. Slowly lower the tank until the top of the tank is almost visible. Use blocks or stands to support the tank while installing the Front Upper and Lower Brackets.
- e. Proceed to **Step 8**.

On 2017 models and on:

- a. If necessary, remove the (4) hex bolts attaching plastic cover to DEF tank, **(Figure 11)** and remove plastic cover for better access. **NOTE:** On 2017-on 2500/3500 models, only remove plastic cover from DEF tank. **Do not lower DEF tank** and proceed to **Step 8**.
8. Locate the first tab on the edge of the pinch weld. Select the Upper Bracket. Repeat **Steps 2 & 3** to attach the Passenger/Right Upper Mounting Bracket to the side of the rocker panel, **(Figures 12 & 13)**. Do not tighten hardware.
9. Line up the hole in the bottom of the Upper Bracket with the hole in the tab on the pinch weld.
 - a. **Models with a weld-nut:** Slide the Bracket over the weld-nut, **(Figure 13)**. Attach the Lower Mounting Bracket to the bottom of the pinch weld and weld-nut with (1) 8mm Hex Bolt, (1) 8mm Lock Washer and (1) 8mm Flat Washer, **(Figure 17)**. Do not tighten hardware.
 - b. **Models with flat tab and hole:** Insert the 8mm Bolt Plate down through the hole in the Upper Mounting Bracket and mounting tab. Attach the Lower Bracket to the bottom of the body and Bolt

Plate with (1) 8mm Flat Washer and (1) 8mm Nylon Lock Nut. Leave loose at this time, **(Figures 14—16)**. Do not tighten hardware at this time.

10. Line up the side tab on the Lower Bracket with the threaded hole in the side of the Upper Bracket. Attach the Lower Bracket to the Upper Bracket with (1) 8mm Hex Bolt, (1) 8mm Lock Washer and (1) 8mm Flat Washer, **(Figures 16 & 17)**. Leave loose at this time.
11. Repeat **Steps 1—4** to attach the remaining (3) Mounting Brackets to the Passenger/Right rocker panel.
12. **For 2017 2500/3500 DEF tank models:** Locate the 2nd mounting location along the bottom edge of the body, (pinch weld), **(Figure 1)**. Hold the DEF cover in place and mark the 2nd Bracket location onto the cover, **(Figure 19)**. Use a sharp knife or hacksaw blade to carefully cut a slot in the plastic cover to clear the 2nd Bracket, **(Figure 20)**. Remove as little plastic as possible.
13. Repeat **Steps 5 & 6** to attach the Passenger/Right RS2 Running Board.
14. Once the Running Board has been attached and all hardware fully tightened, reinstall the DEF tank and cover, if equipped, as described in **Step 7**.
15. Do periodic inspections to the installation to make sure that all hardware is secure and tight.

To protect your investment, Do not use any type of polish or wax that may contain abrasives that could damage the finish. Mild soap may be used also to clean the Sidebars.

Driver/Left Side Installation Pictured

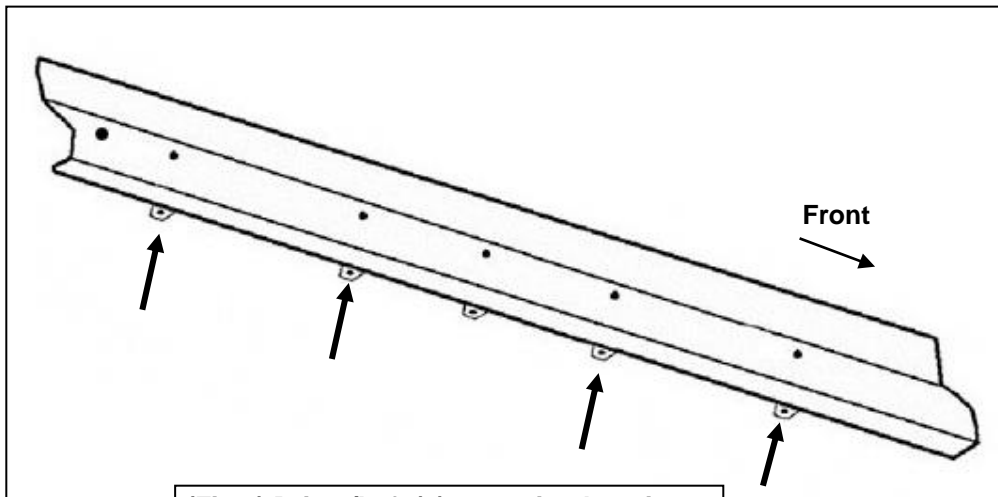

(Fig 1) Driver/Left (4) mounting locations

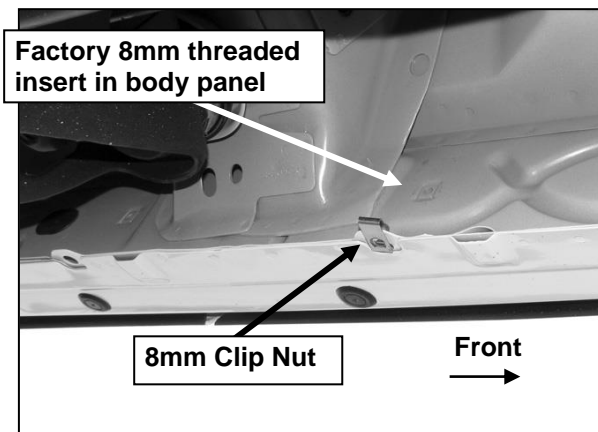

(Fig 3) Driver/Left Center mounting location

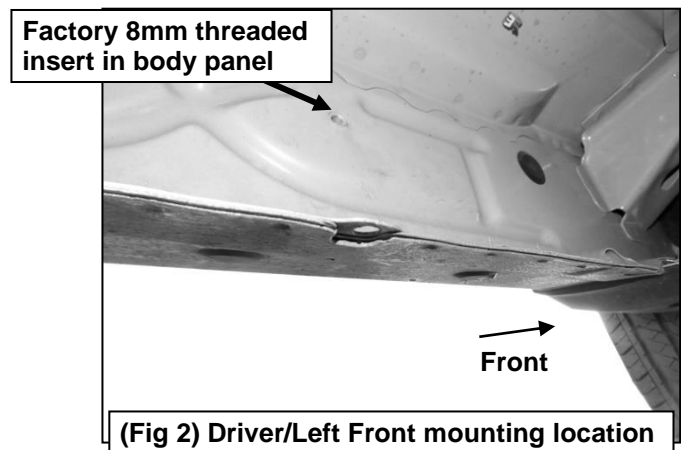

(Fig 2) Driver/Left Front mounting location

Driver/Left Side Installation Pictured

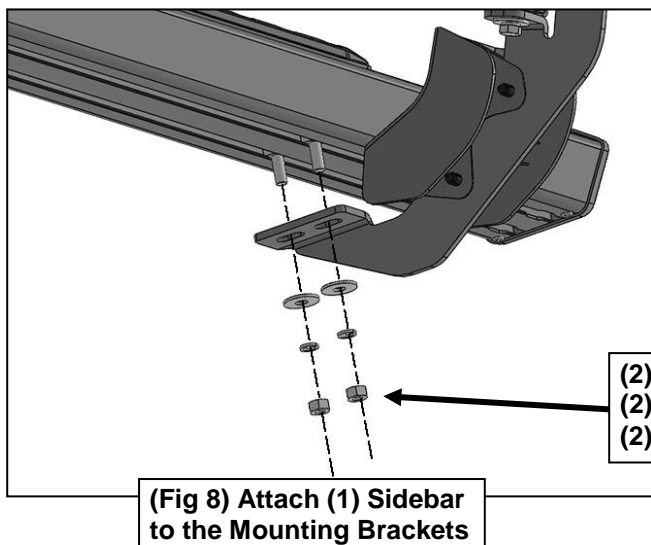
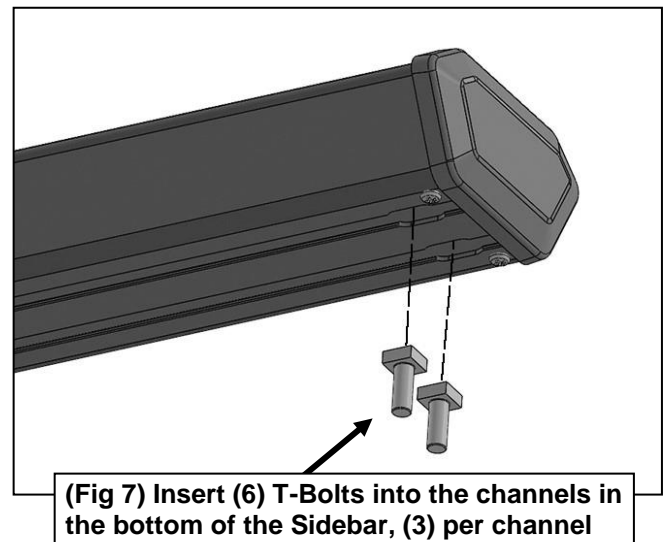
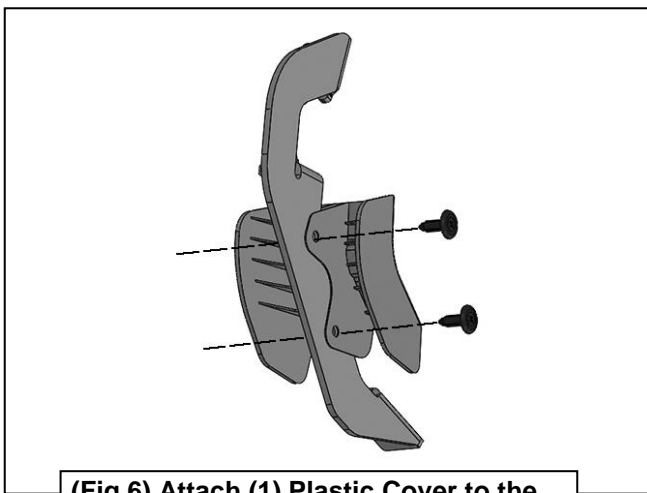
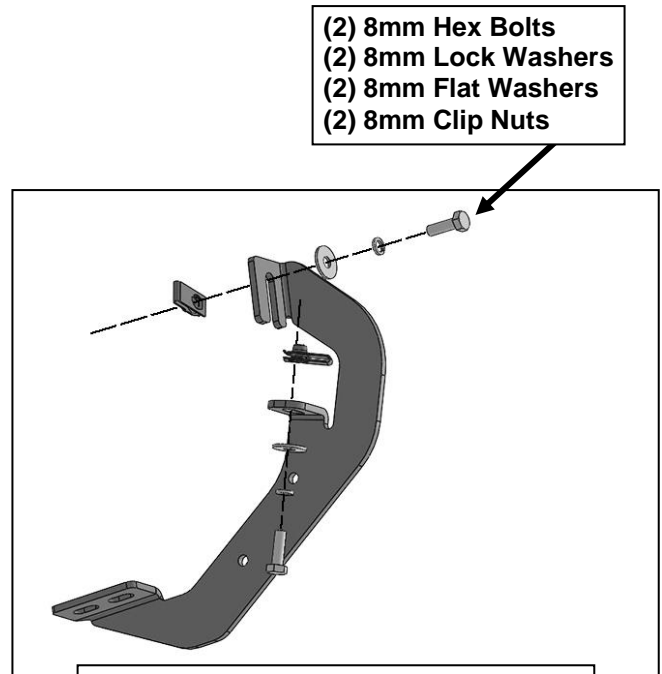
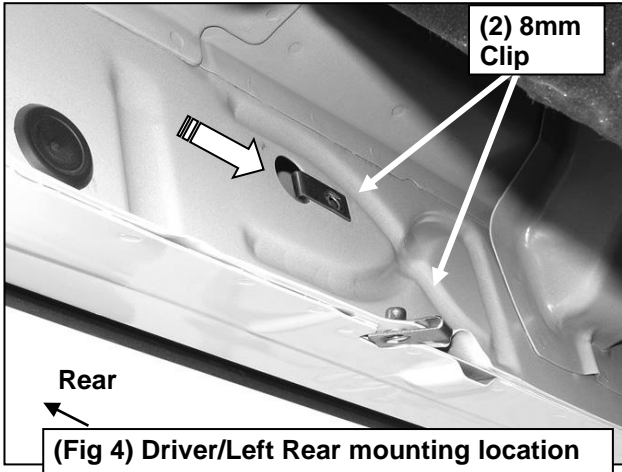

Passenger/Right Front Installation Pictured

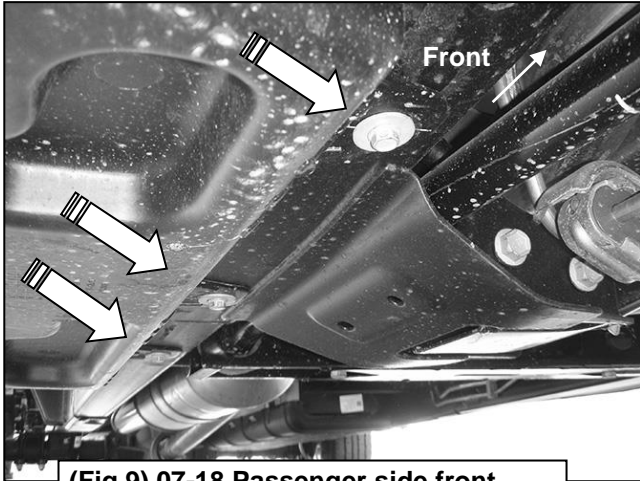

(Fig 9) 07-18 Passenger side front pictured with DEF tank cover. Remove (3) hex bolts to remove cover

Remove (2) factory bolts to remove tank straps

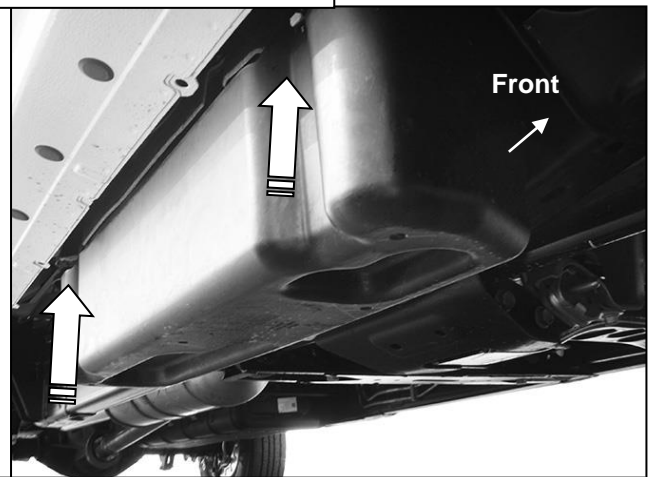

(Fig 10) 07-18 Passenger side DEF tank and cover

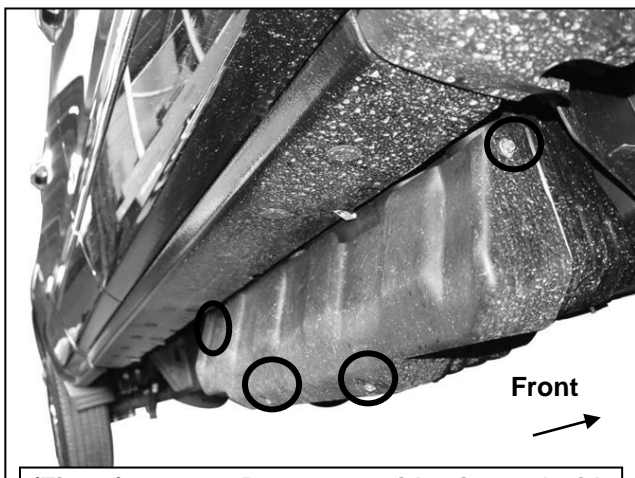

(Fig 11) 2017-on Passenger side pictured with DEF plastic tank cover. If needed, remove (4) hex bolts to remove plastic cover.

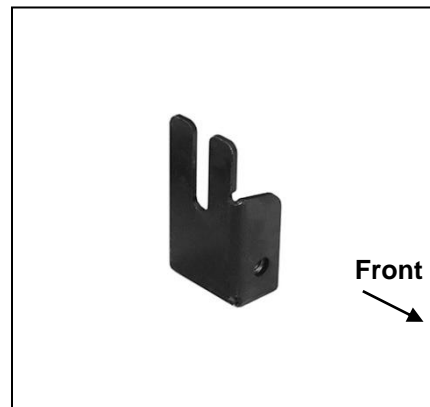

(Fig 12) Passenger/Right Front Upper Bracket (all models)

Passenger/right Front Installation Pictured

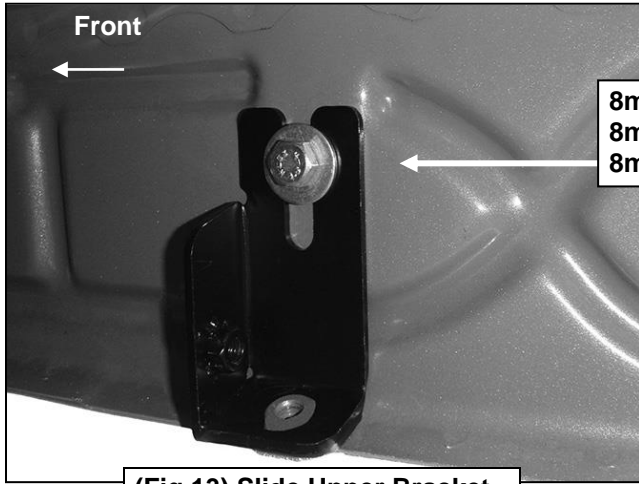

(Fig 13) Slide Upper Bracket over weld nut if equipped



On models with flat tab, insert 8mm Bolt Plate (Fig 16) down through Upper Bracket and mounting tab

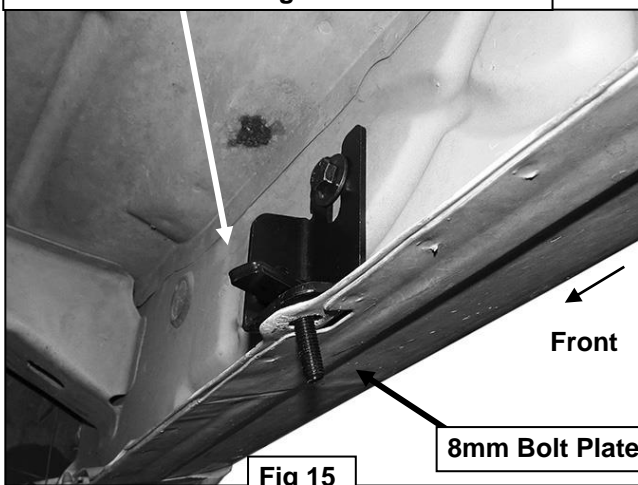

Passenger/Right Front Installation Pictured

8mm x 25mm Hex Bolt
8mm Lock Washer
8mm Flat Washer

8mm Bolt Plate
8mm Flat Washer
8mm Nylon Lock Nut

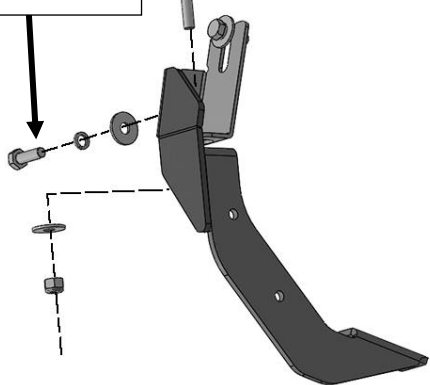

(Fig 16) For models with a hole in the pinch weld

8mm x 25mm Hex Bolt
8mm Lock Washer
8mm Flat Washer

8mm x 40mm Hex Bolt
8mm Flat Washer
8mm Nylon Lock Nut

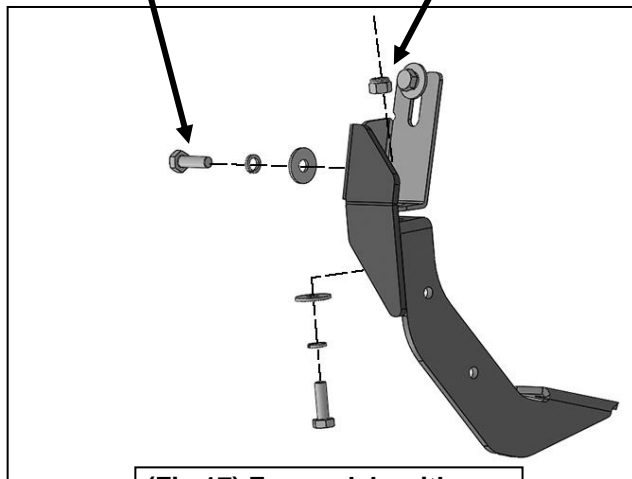

(Fig 17) For models with welded nut in the pinch weld

mark pictured is approximately 70mm x 10mm



(Fig 19) 2017-on Passenger side DEF cover marked for trimming

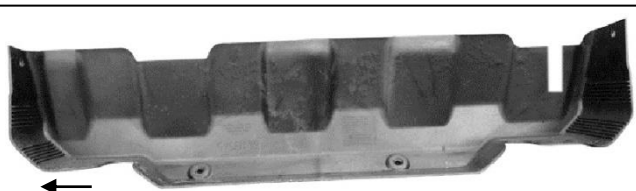

Front

(Fig 20) 2017-on Passenger DEF cut for example only

PRODUCT CARE

- Periodically check the product to ensure all fasteners are tight and components are intact.
- For cleaning, use mild soap and warm water with a soft cloth or brush to prevent scratching.

FAQ's**1. Hardware and mounting brackets are not aligning properly**

Ensure that hardware is being used on the correct side of the vehicle. In some cases, the hardware may appear same for driver or passenger side but may alter the alignment of mounting location. Check mounting brackets for both sides.

2. Step Bar is not aligning with vehicle / doors

Step bars may be interchanged or reversed (Driver / Passenger Side). Check step bar for each side as well ensure the proper hardware has been used for each side.

3. Products are thumping / rattling after installation.

Ensure that all required mounting brackets / hardware's are installed & tighten correctly. Suggest using white lithium / regular grease between metal to metal contact.

4. Missing / Excess Hardware.

Recheck hardware count as per the part list.

5. Product not installing properly.

Ensure the Year / Make / Model as well as cab and bed dimensions are correct for the application. Review all steps for installation to ensure they were followed correctly.

6. Who should be contacted for questions regarding product / installation assistance?

www.trailfx.com / support@trailfx.com 1-(866) 638-4870

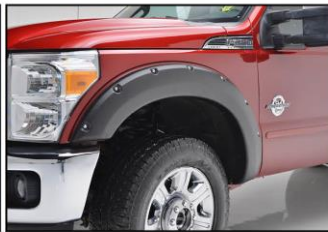
Check out these other TrailFX Products!www.trailfx.com**HOOD PROTECTOR****FENDER FLARES****TONNEAU COVER****BED LINERS**

Keystone Automotive Operations Inc. (KAO) warrants this product to be free of defects in material and workmanship at the time of purchase by the original retail consumer. KAO disclaims any other warranties, express or implied, including the warranty of fitness for a particular purpose or an intended use. If the product is found to be defective, KAO may replace or repair the product at our option, when the product is returned prepaid, with proof of purchase. Alteration to, improper installation, or misuse of this product voids the warranty. KAO's liability is limited to repair or replacement of products found to be defective, and specifically excludes liability for any incidental or consequential loss or damage.