

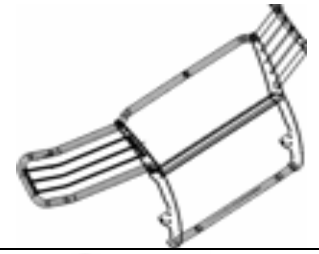

Grille Guard

Part No. E0039B/S



Fits: 2019-2020 RAM 2500-5500



RATCHET, SOCKET SET AND WRENCH SET



90 Mins



Cutting Not Required



Drilling Not Required



REMOVE CONTENTS FROM BOX. VERIFY ALL PARTS ARE PRESENT



support@trailfx.com



READ INSTRUCTIONS CAREFULLY BEFORE STARTING INSTALLATION



1- (866) 638 - 4870

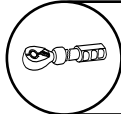

M10 BOLT
M12 BOLT

COATED HARDWARE

37 FOOT POUND
65 FOOT POUND

SS HARDWARE

24 FOOT POUND
42 FOOT POUND



POLISHED STAINLESS STEEL – LIMITED LIFETIME
POWDER COATED BLACK – 3 YEARS

PARTS LIST:

Qty	Part Description	Qty	Part Description
1	Grille Guard	4	12mm x 37mm x 3mm Large Flat Washers
1	Driver/left Frame Bracket	12	12mm x 32mm x 3mm Flat Washers
1	Passenger/right Frame Bracket	2	12mm Lock Washers
1	Driver/left Top Bracket	2	12mm Hex Nuts
1	Passenger/right Top Bracket	6	12mm Nylon Lock Nuts
1	Driver/left Top Support Bracket	2	10-1.5mm x 35mm Hex Bolts
1	Passenger/right Top Support Bracket	2	10mm x 24mm x 2.2mm Flat Washers
1	Driver/left Frame Support Bracket	2	10mm Lock Washers
1	Passenger/right Frame Support Bracket	6	8-1.25mm x 30mm Hex Bolts
2	12-1.75mm x 120mm Hex Bolts	6	8mm x 22mm x 2mm Flat Washers
6	12-1.75mm x 35mm Hex Bolts	6	8mm Lock Washers
1	Grille Guard	4	12mm x 37mm x 3mm Large Flat Washers

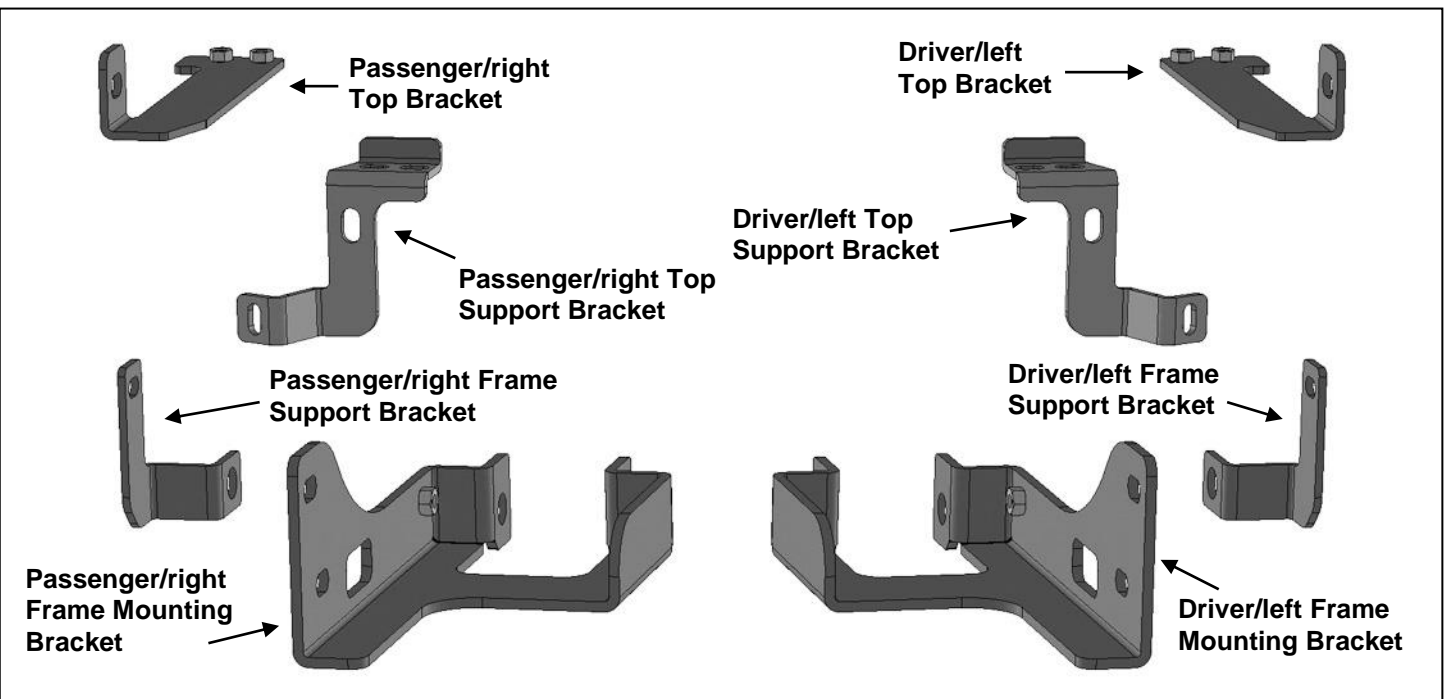

PROCEDURE:

REMOVE CONTENTS FROM BOX. VERIFY ALL PARTS ARE PRESENT. READ INSTRUCTIONS CAREFULLY BEFORE STARTING INSTALLATION. ASSISTANCE IS RECOMMENDED. INSTALLATION MAY INTERFERE WITH FRONT BUMPER MOUNTED SENSORS.

1. Start installation under the driver/left side of the front bumper. Remove the factory hex nut attaching the top of the bumper to the top/center of the bumper bracket, (**Figure 1**). Next, remove the factory hex bolt attaching the top of the bumper reinforcement to the bumper bracket. **NOTE:** Select the driver/left Top Mounting Bracket. Hold the Bracket up to the back of the bumper bracket to help determine correct hardware to remove, (**Figure 2**).
2. Reuse the factory hex nut to attach the driver/left Top Support Bracket to the threaded stud on back of the bumper bracket, (**Figure 2**). Attach the Bracket to the back of the bumper bracket with the supplied longer (1) 8mm x 30mm Hex Bolt, (1) 8mm Lock Washer and (1) 8mm Flat Washer, (**Figures 2 & 6**). Do not fully tighten hardware at this time.
3. Select the driver/left Top Bracket, (**Figure 5**). Slide the flat end of the Bracket through the gap between the top of the bumper and the bottom of the grille, (**Figure 3 & 4**). Attach the Top Bracket to the top of the Support Bracket with the included (2) 8mm x 30mm Hex Bolts, (2) 8mm Lock Washers and (2) 8mm Flat Washers, (**Figures 5 & 6**). Do not fully tighten hardware at this time.
4. Next, remove the (2) factory hex bolts attaching the driver/left tow hook, (**Figure 7**). **IMPORTANT:** Tow hook bolts are held in place with high torque. Breaker bar or air assisted tools may be required to remove factory bolts. Once hardware has been removed, slide the tow hook out through the bumper.
5. Select the driver/left Frame Mounting Bracket, (**Figure 8**). Place the tow hook on top of the Bracket. Slide the Bracket and tow hook through the opening in the front bumper. Reuse the factory hex bolt to attach the tow hook to the rear mounting hole in the frame, (**Figures 7—9**). Use the included longer 12mm x 120mm Hex Bolt (2) 12mm x 37mm Large Flat Washers, (1) 12mm Lock Washer and (1) 12mm Hex Nut to attach the Bracket and tow hook to the forward tow hook mounting hole, (**Figures 8 & 9**).
6. Remove the factory hex bolt from the side of the frame, (**Figure 9**). Select the driver/left Frame Support Bracket, (**Figure 10**). Reuse the factory hex bolt to attach the Support Bracket to the frame. Attach the top of the Support Bracket to the side of the Frame Bracket with the included (1) 10mm x 35mm Hex Bolt, (1) 10mm Lock Washer and (1) 10mm Flat Washer, (**Figure 10**). Leave hardware loose.
7. Repeat **Steps 1—6** to install the passenger/right Top and Frame Mounting Brackets.
8. With assistance, hold the Grille Guard up to the outside of the Brackets. Attach the Grille Guard to the Brackets with the included (6) 12mm x 35mm Hex Bolts, (12) 12mm x 32mm Flat Washers and (6) 12mm Nylon Lock Nuts, (**Figures 11 & 12**).
9. Stand back from the vehicle and check to see that the Grille Guard is centered and level on the vehicle and adjust as necessary. Once adjusted, fully tighten all hardware.
10. Do periodic inspections to the installation to make sure that all hardware is secure and tight.

To protect your investment, wax this product after installing. Regular waxing is recommended to add a protective layer over the finish. Do not use any type of polish or wax that may contain abrasives that could damage the finish.

For stainless steel: Aluminum polish may be used to polish small scratches and scuffs on the finish. Mild soap may be used also to clean the Grille Guard. **For gloss black finishes:** Mild soap may be used to clean the Grille Guard.

Driver Side Installation Pictured

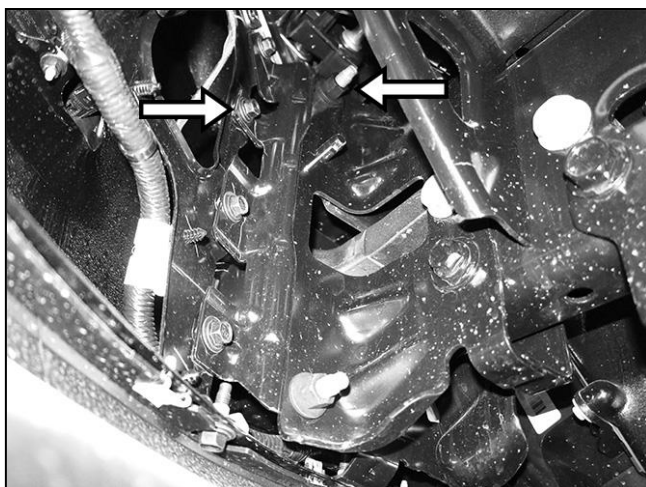

(Fig 1) Remove top hex nut and hex bolt from back of bumper bracket (arrows).

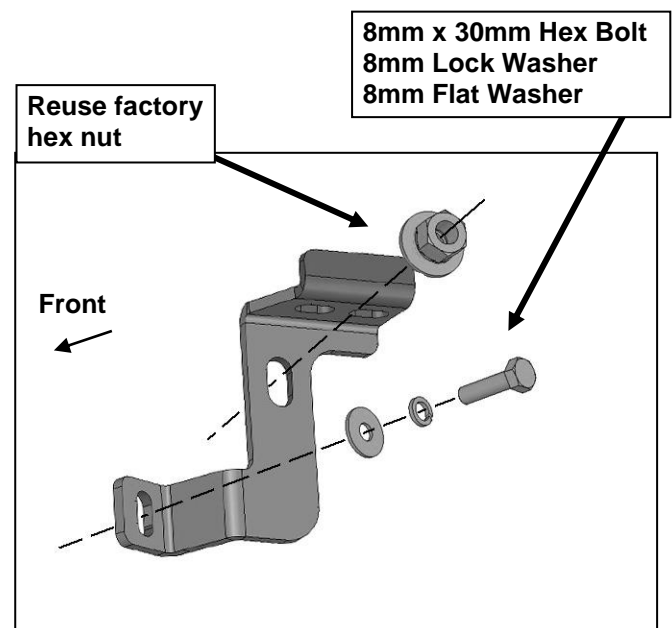

(Fig 2) Attach driver/left Top Support Bracket to back of bumper bracket

Driver Side Installation Pictured

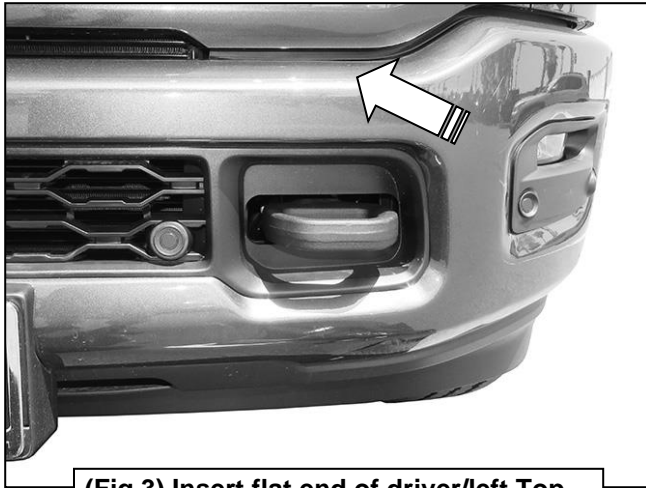

(Fig 3) Insert flat end of driver/left Top Bracket through bumper (arrow)

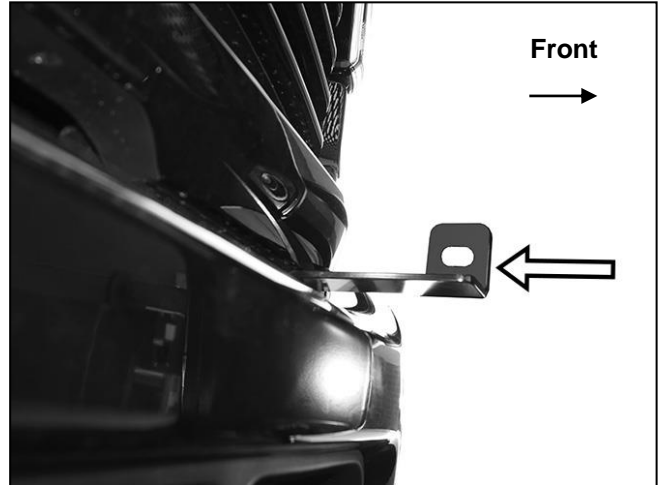

(Fig 4) Insert flat end of driver/left Top Bracket through bumper (arrow)

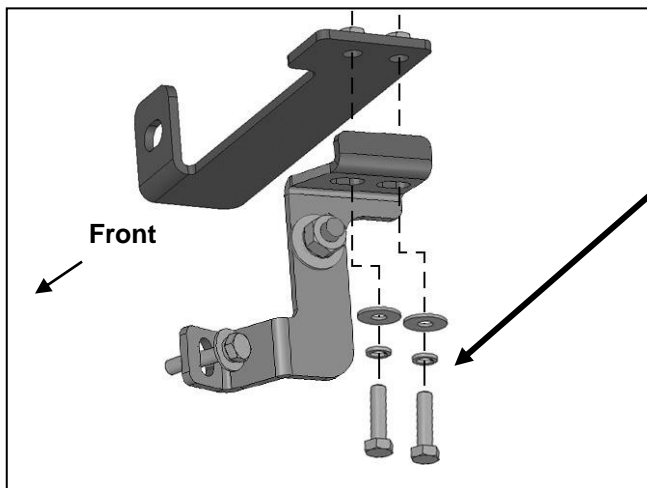

- (2) 8mm x 30mm Hex Bolts
- (2) 8mm Lock Washers
- (2) 8mm Flat Washers

(Fig 5) Attach driver/left Top Bracket to Top Support Bracket

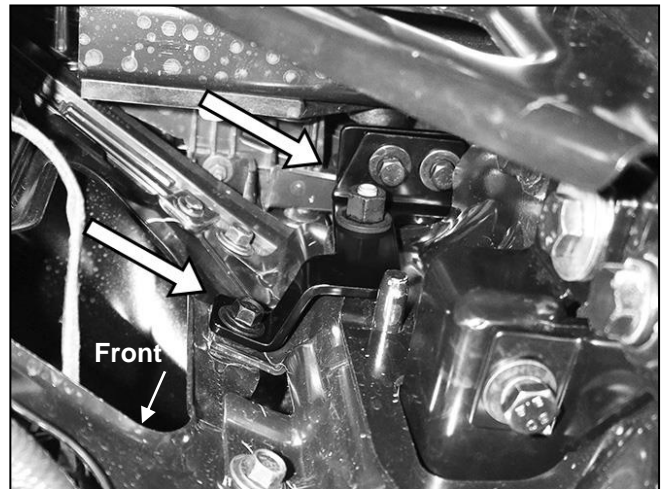

(Fig 6) Driver/left Top Bracket and Top Support Bracket pictured from behind bumper

Driver Side Installation Pictured

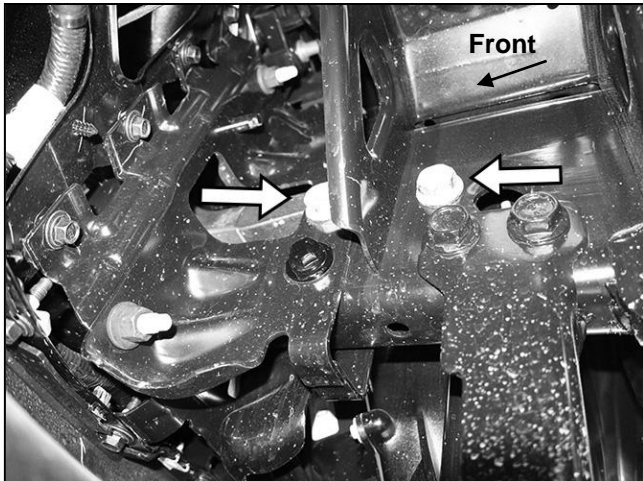

(Fig 7) Remove hex bolts to remove tow hook

- 12mm x 120mm Hex Bolt
- (2) 12mm x 37mm Large Flat Washers
- 12mm Lock Washer
- 12mm Hex Nut

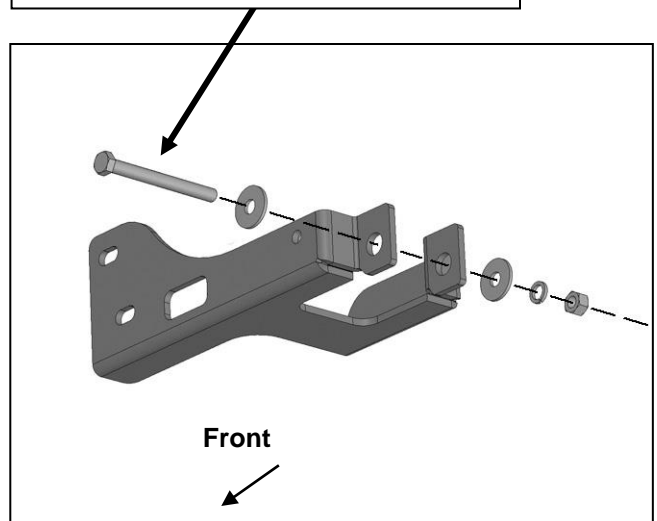

Driver/left Frame Bracket to tow hook and forward tow hook mounting hole

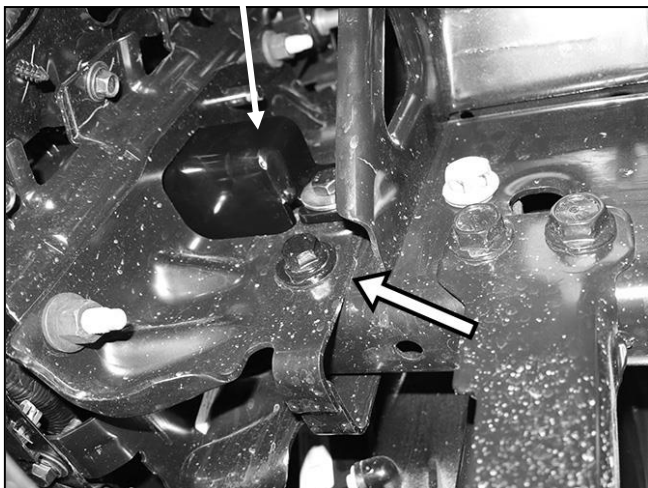

(Fig 9) Remove hex bolt (arrow)

(Fig 8) Attach driver/left Frame Bracket to tow hook and forward tow hook mounting hole

Driver Side Installation Pictured

10mm x 35mm Hex Bolt
10mm Lock Washer
10mm Flat Washers

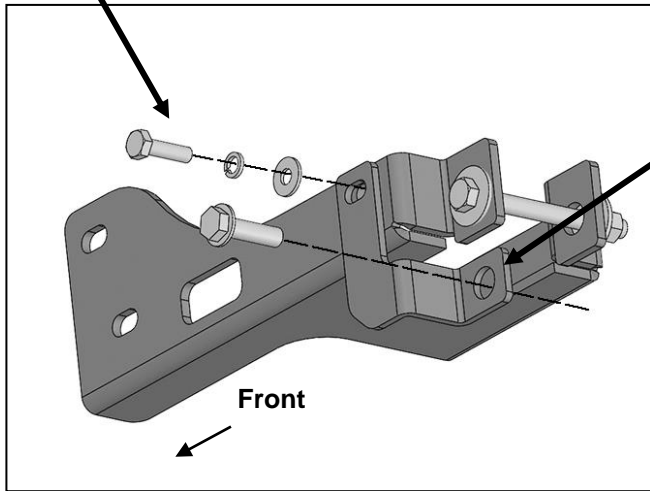

Reuse factory
hex bolt (Fig 9)

(3) 12mm x 35mm Hex Bolts
(6) 12mm x 32mm STD Flat Washers
(3) 12mm Nylon Lock Nuts

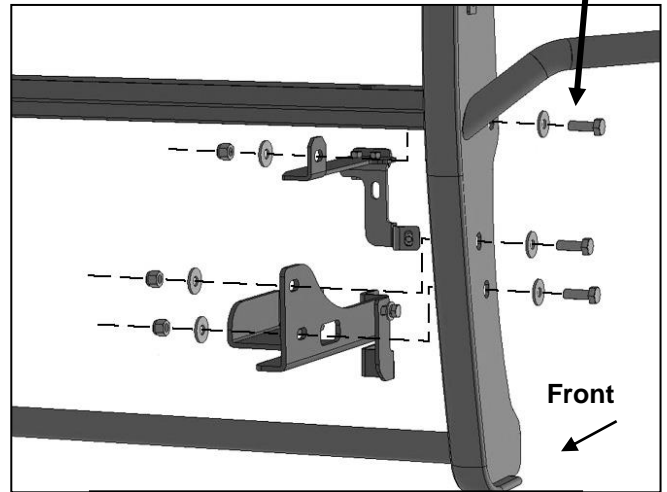

(Fig 10) Attach driver/left Frame Support Bracket to side of frame and bottom of Frame Bracket

(Fig 11) Attach Grill Guard to outside of driver/left Mounting Brackets



(Fig 12) Attach Grill Guard to outside of Mounting Brackets (passenger/right side pictured)



PRODUCT CARE

- Periodically check the product to ensure all fasteners are tight and components are intact.
- Regular waxing is recommended to protect the finish of the product.
- **Use ONLY Non-Abrasive automotive wax.** Use of any soap, polish or wax that contains an abrasive is detrimental and can scratch the finish leading to corrosion.
- Aluminum polish may be used to polish small scratches and scuffs for **Stainless Steel finish.**
- Mild soap may be used to clean the product for both **Stainless Steel and Black finish.**

FAQ's**1. Hardware and mounting brackets are not aligning properly**

Ensure that hardware is being used on the correct side of the vehicle. In some cases, the hardware may appear same for driver or passenger side but may alter the alignment of mounting location. Check mounting brackets for both sides.

2. Grille Guard is not aligning with vehicle

Grille Guard Brackets may be interchanged or reversed (Driver / Passenger Side). Check Brackets for each side as well ensure the proper hardware has been used for each side.

3. Products are thumping / rattling after installation.

Ensure that all required mounting brackets / hardware's are installed & tighten correctly. Suggest using white lithium / regular grease between metal to metal contact.

4. Missing / Excess Hardware.

Recheck hardware count as per the part list.

5. Product not installing properly.

Ensure the Year / Make / Model as well as cab and bed dimensions are correct for the application. Review all steps for installation to ensure they were followed correctly.

6. Who should be contacted for questions regarding product / installation assistance?

www.trailfx.com / support@trailfx.com 1-(866) 638-4870

Check out these other TrailFX Products!www.trailfx.com**BED LINERS****TONNEAU COVERS****HOOD PROTECTORS****OVAL STEP BARS**

Keystone Automotive Operations Inc. (KAO) warrants this product to be free of defects in material and workmanship at the time of purchase by the original retail consumer. KAO disclaims any other warranties, express or implied, including the warranty of fitness for a particular purpose or an intended use. If the product is found to be defective, KAO may replace or repair the product at our option, when the product is returned prepaid, with proof of purchase. Alteration to, improper installation, or misuse of this product voids the warranty. KAO's liability is limited to repair or replacement of products found to be defective, and specifically excludes liability for any incidental or consequential loss or damage.