

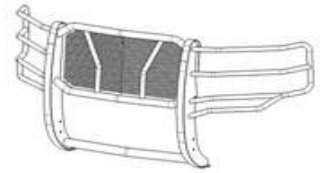

Extreme Grille Guard

Part No. E0517B



Fits: **2019-2020**

SIERRA 1500



RATCHET, SOCKET SET AND WRENCH SET



90 Mins

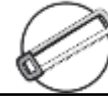

CUTTING May Be
REQUIRED



DRILLING NOT
REQUIRED



REMOVE CONTENTS FROM BOX. VERIFY ALL PARTS ARE PRESENT



support@trailfx.com



READ INSTRUCTIONS CAREFULLY BEFORE STARTING INSTALLATION



1- (866) 638 - 4870

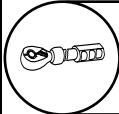

M8 BOLT 18 FOOT POUND
M10 BOLT 37 FOOT POUND
M12 BOLT 65 FOOT POUND



POWDER COATED BLACK – 3 YEARS

PARTS LIST:

Qty	Part Description	Qty	Part Description
1	XHD Grille Guard	14	12mm Lock Washers
1	Driver/Left Frame Bracket	14	12mm Hex Nuts
1	Passenger/Right Frame Bracket	6	12mm Plastic Retainers
1	Driver/Left Z-Bracket	2	10-1.5mm x 30mm Hex Bolts
1	Passenger/Right Z-Bracket	4	10mm x 24mm OD x 2.2mm Flat Washers
1	Driver/Left Support Bracket	2	10mm Nylon Lock Nuts
1	Passenger/Right Support Bracket	2	8-1.25mm x 25mm Hex Bolts
8	12-1.75mm x 35mm Hex Bolts	4	8mm x 24mm OD x 2mm Flat Washers
2	12-1.75mm x 35mm Bolt Plates	2	8mm Lock Washers
2	12-1.75mm x 30mm Double Bolt Plates	2	8mm Hex Nuts
16	12mm x 32mm OD x 3mm Flat Washers	2	Foam Strips
6	12mm x 24mm OD x 2.5mm Flat Washers	1	2.5mm Hex Wrench

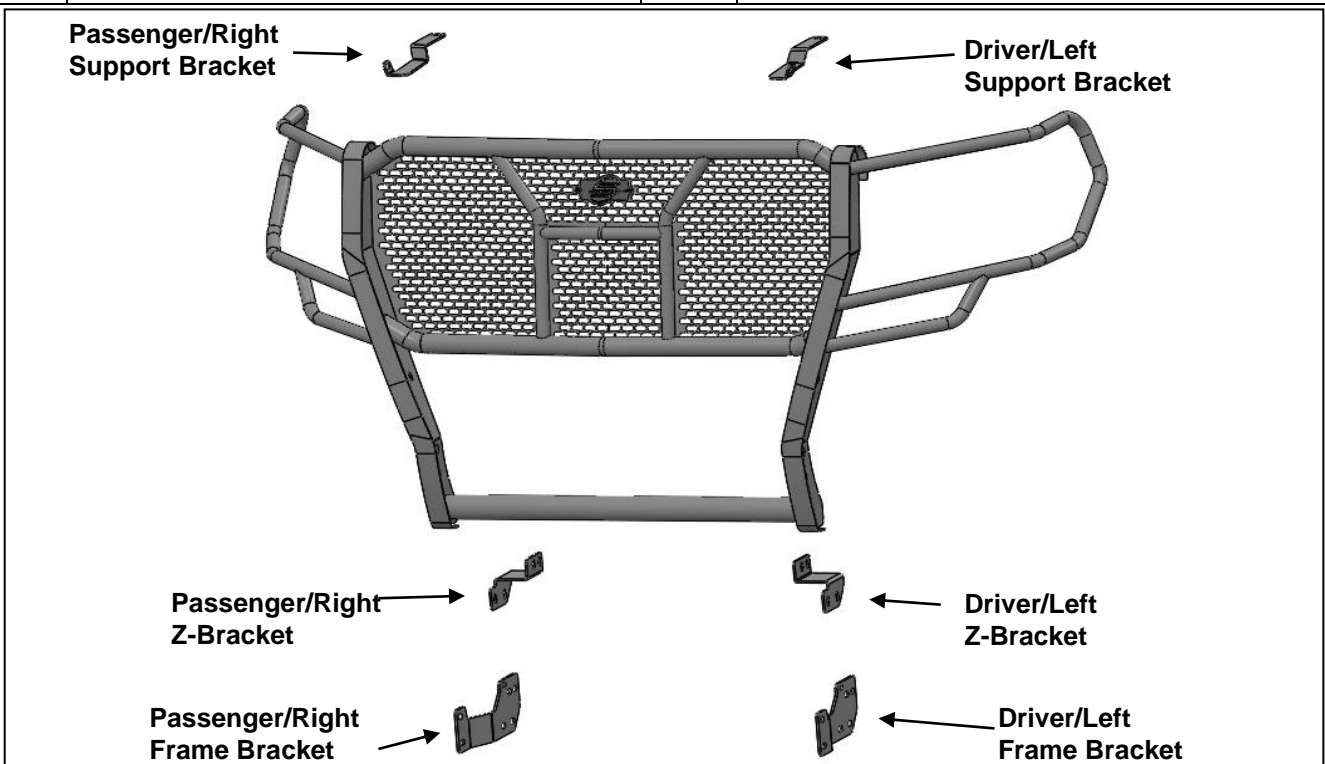

PROCEDURE:

REMOVE CONTENTS FROM BOX AND VERIFY ALL PARTS ARE PRESENT. READ INSTRUCTIONS CAREFULLY. CUTTING MAY BE REQUIRED. ASSISTANCE IS HIGHLY RECOMMENDED. INSTALLATION MAY INTERFERE WITH FRONT MOUNTED SENSORS. IT MAY BE NECESSARY TO REMOVE THE BUMPER.

1. Remove the factory tow hook and plastic cover, if equipped, **(Figures 1 & 2)**.
2. **For models not equipped with tow hooks**, cut out the indented area in both sides of the plastic bumper insert to clear the Brackets as pictured, **(Figure 3)**. **IMPORTANT:** Make several small cuts for best fit. Do not cut through the top or bottom edge of the panel.
3. Select the Driver/Left Frame Bracket. Line up the holes in the Frame Bracket with the holes in the outer frame for the tow hook.

Models without tow hooks:

- a. Select (1) 12mm Bolt Plate. Insert the Bolt Plate into the end of the frame, **(Figure 4)**. Thread (1) 12mm Plastic Retainers onto the Bolt Plate to hold it in place, **(Figure 5)**.
- b. Attach the Frame Bracket to the Bolt Plate with (1) 12mm x 24mm Flat Washer, (1) 12mm Lock Washer and (1) 12mm Hex Bolt, **(Figure 6)**. Do not tighten hardware at this time.
- c. Attach the Frame Bracket to the frame with (1) 8mm Hex Bolt, (2) 8mm Flat Washers, (1) 8mm Lock Washer and (1) 8mm Hex Nut, **(Figures 6 & 7)**.
- d. Select (1) 12mm Double Bolt Plate, **(Figure 8)**. Insert the Double Bolt Plate into the inner side of the frame. Thread (2) 12mm Plastic Retainers onto the Double Bolt Plate to hold it in place.
- e. Select the Drive/Left Z-Bracket. Attach the Z-Bracket to the Double Nut Plate with (2) 12mm x 24mm Flat Washers, (2) 12mm Lock Washers and (2) 12mm Hex Nuts, **(Figure 8)**. Do not tighten hardware at this time.
- f. Attach the bottom of the Z-Bracket to the Frame Bracket with (2) 12mm Hex Bolts, (4) 12mm x 32mm Flat Washers, (2) 12mm Lock Washers and (2) 12mm Hex Nuts, **(Figures 9 & 10)**. Do not tighten hardware at this time.

Models with tow hooks:

- a. Reuse the factory hardware to attach the Driver/Left Frame Bracket and the Driver/Left Z-Bracket to the end of the frame.
 - b. Attach the bottom of the Z-Bracket to the Frame Bracket with (2) 12mm Hex Bolts, (4) 12mm x 32mm Flat Washers, (2) 12mm Lock Washers and (2) 12mm Hex Nuts, **(Figures 9 & 10)**. Do not tighten hardware at this time.
4. Repeat **Steps 2 & 3** to attach the Passenger/Right Frame Bracket and Z-Bracket.
 5. Open the hood and carefully remove the grille from the vehicle. **NOTE:** Grille is held in place with screws at the top and several clips. Remove the screws and firmly pull the grille straight out from the vehicle to release the grille from clips, **(Figure 11)**.
 6. Move up to the top of the bumper. Select the Driver/left Support Bracket. Apply a layer of the included Adhesive Backed Foam Tape to the bottom of the Bracket. Trim Foam for best fit.
 7. Lift the flap on top of the bumper to locate the factory hex bolt attaching the top of the bumper to the inner bumper bracket. Temporarily remove the hex bolt, **(Figure 12)**. Reuse the factory hex bolt to attach the Support Bracket to the top of the bumper, **(Figure 13)**. Do not tighten hardware at this time.
 8. Repeat **Steps 6 & 7** to attach the Passenger/Right Support Bracket.
 9. With assistance, hold the Grille Guard up in position on the outside of the Mounting Brackets, **(Figure 14)**. Attach the Grille Guard to the Frame Brackets with (4) 12mm Hex Bolts, (8) 12mm Flat Washers, (4) 12mm Lock Washers and (4) 12mm Hex Nuts, **(Figures 14 & 15)**. Do not tighten hardware at this time.
 10. Attach the Support Brackets to the Grille Guard with (2) 10mm Hex Bolts, (4) 10mm Flat Washers and (2) 10mm Nylon Lock Nuts, **(Figures 14 & 15)**. Check the Grille guard alignment with the vehicle. Adjust as required then fully tighten the Top and Frame Bracket to vehicle hardware only. Do not fully tighten the Grille Guard to Bracket hardware at this time.
 11. Reinstall the grille. **NOTE:** Loosen the hardware attaching the Grille Guard to the Brackets and tilt the Grille Guard forward to make room to reinstall the grille. **IMPORTANT:** Support Bracket to back of bumper hardware must be fully tightened before reinstalling the grille.
 12. Level and adjust the Grille Guard and fully tighten all hardware.
 13. On models with grille mounted front camera, remove the center panel from the Grille Guard.
 14. Do periodic inspections to the installation to make sure that all hardware is secure and tight.

To protect your investment, wax this product after installing. Regular waxing is recommended to add a protective layer over the finish. Do not use any type of polish or wax that may contain abrasives that could damage the finish. Mild soap may be used also to clean the Grille Guard.

Driver/Left Side Installation Pictured

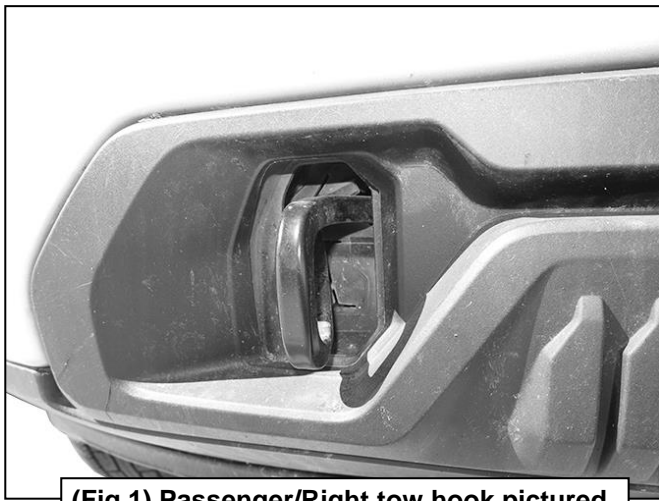

(Fig 1) Passenger/Right tow hook pictured

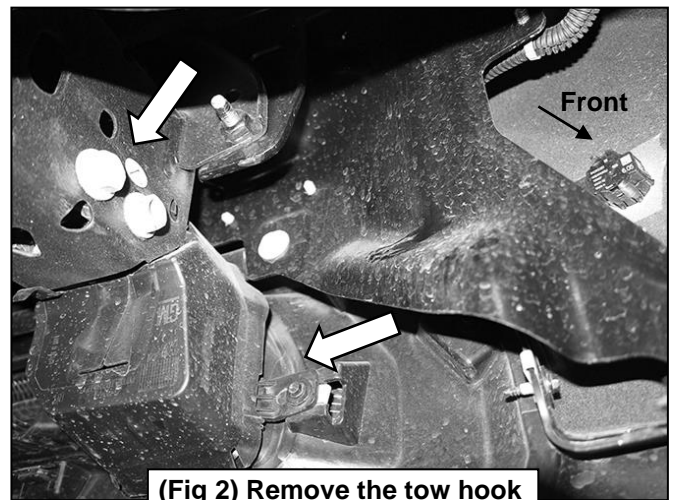

(Fig 2) Remove the tow hook and the plastic cover

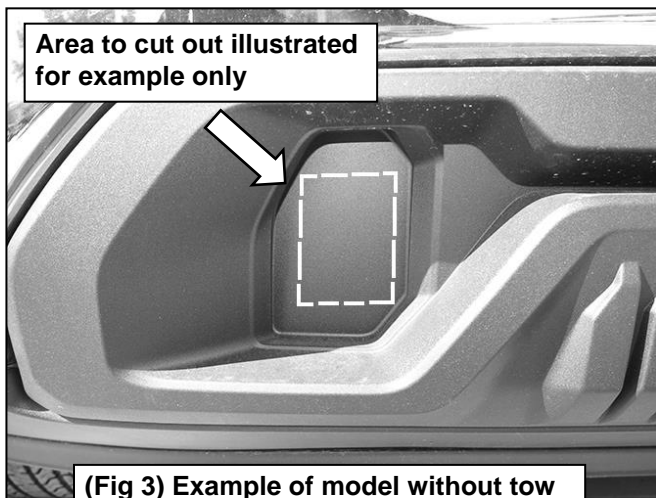

(Fig 3) Example of model without tow hooks, passenger/right side pictured

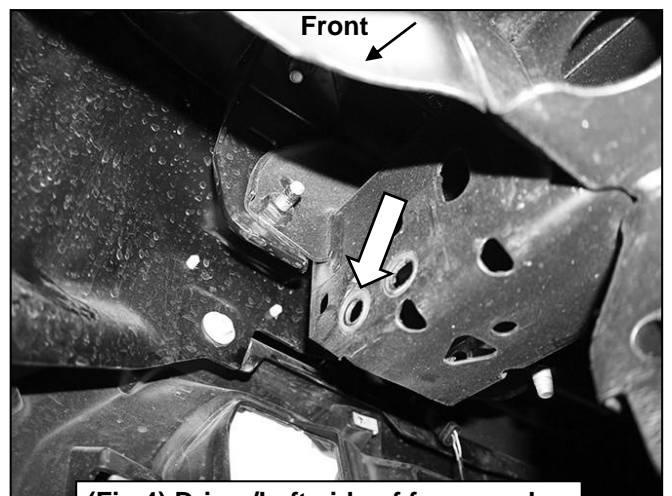

(Fig 4) Driver/Left side of frame and bumper pictured from behind bumper

Driver/Left Side Installation Pictured

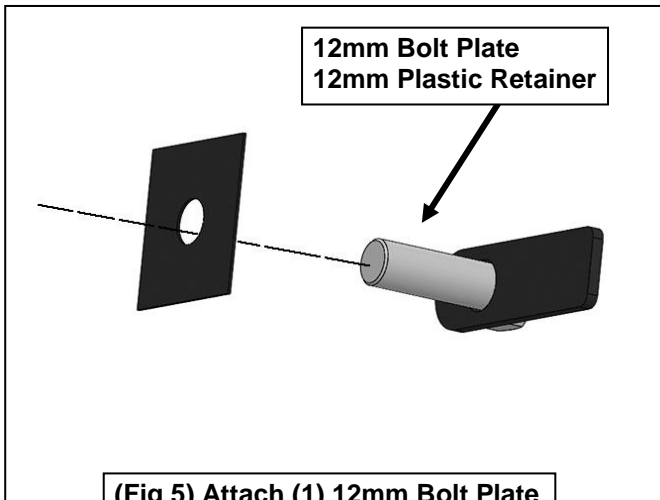

(Fig 5) Attach (1) 12mm Bolt Plate to the outer side of the frame

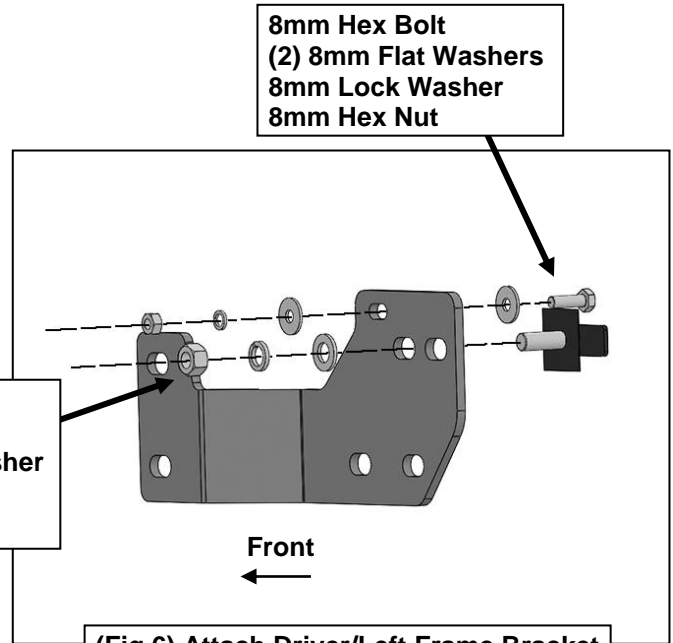

(Fig 6) Attach Driver/Left Frame Bracket to end of frame with Bolt Plate

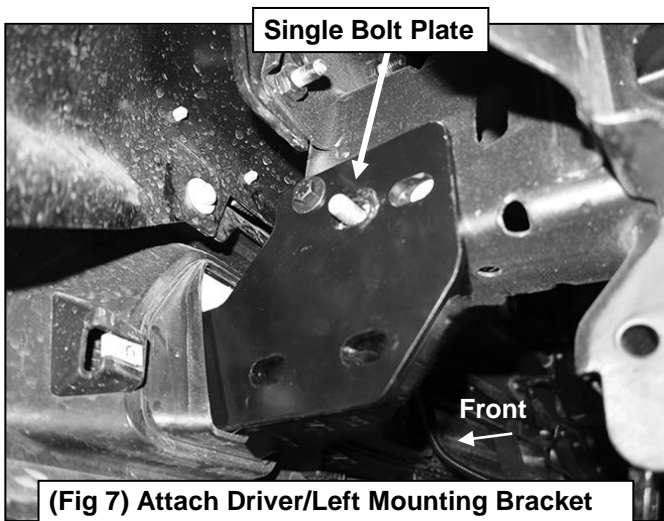

(Fig 7) Attach Driver/Left Mounting Bracket assembly to end of frame with Bolt Plates

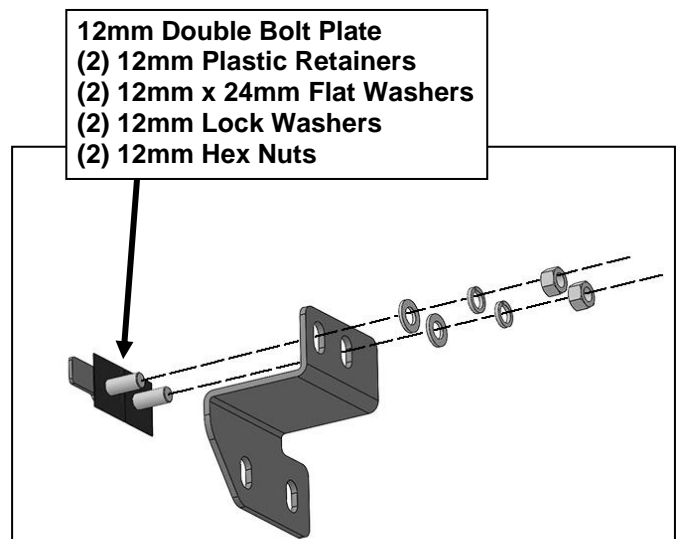

(Fig 8) Attach Driver/Left Z-Bracket to the inner face of the end of frame with Bolt Plates

Driver/Left Side Installation Pictured

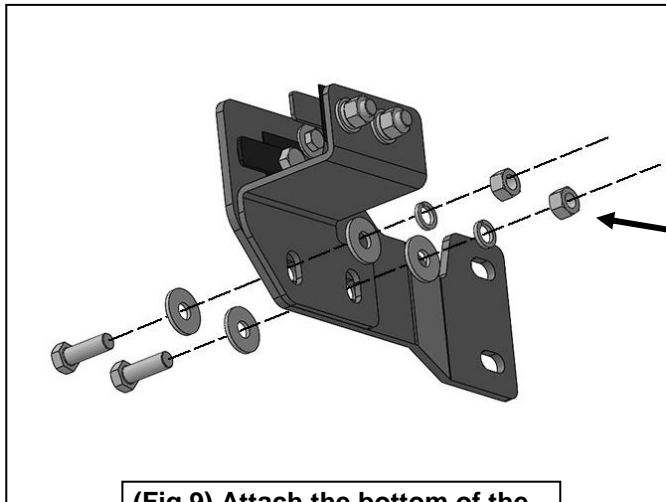

- (2) 12mm Hex Bolts
- (4) 12mm x 32mm Flat Washers
- (2) 12mm Lock Washers
- (2) 12mm Hex Nuts

(Fig 9) Attach the bottom of the Z-Bracket to the Frame Bracket

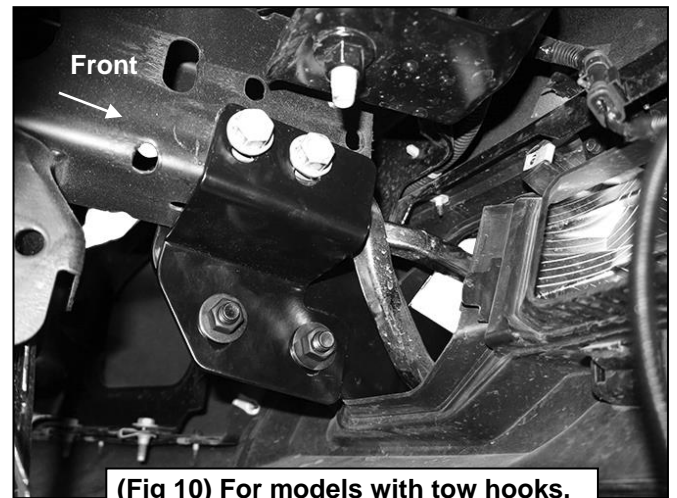

(Fig 10) For models with tow hooks, reuse the factory hardware to attach the tow hook and Z-Bracket



(Fig 11) Remove plastic cover from top of grille

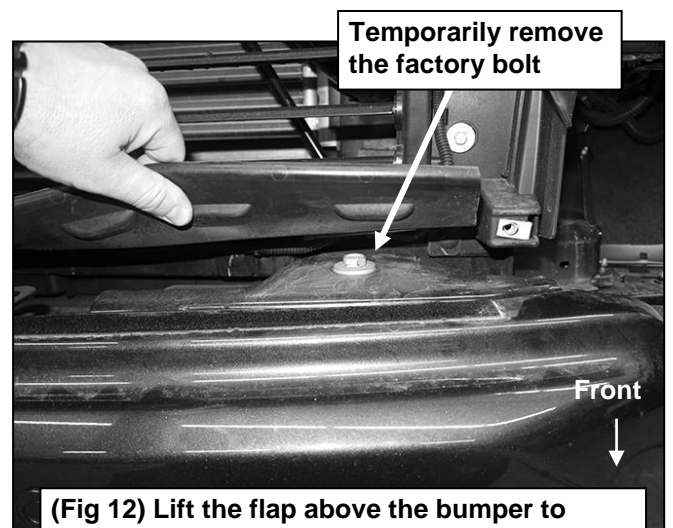

(Fig 12) Lift the flap above the bumper to reveal the Support Bracket mounting location

Driver/Left Side Installation Pictured

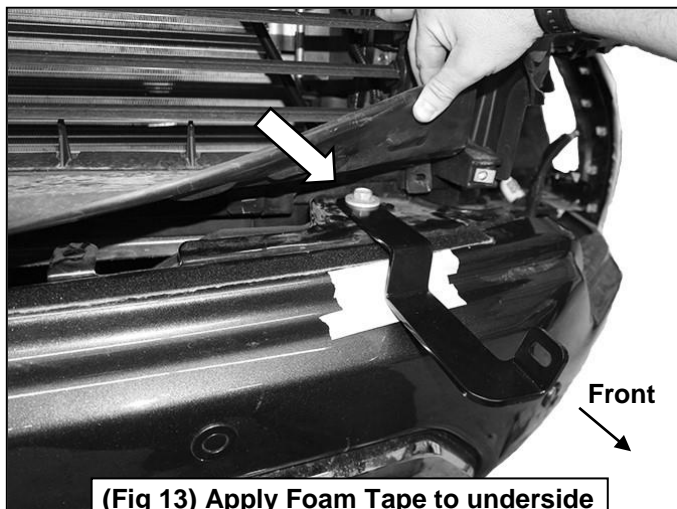

(Fig 13) Apply Foam Tape to underside of Driver/left Support Bracket. Reuse the factory bolt to attach the Bracket to the top of the bumper

- 10mm Hex Bolt
- (2) 10mm Flat Washers
- 10mm Nylon Lock Nut

- (2) 12mm Hex Bolts
- (4) 12mm Flat Washers
- (2) 12mm Lock Washers
- (2) 12mm Hex Nuts

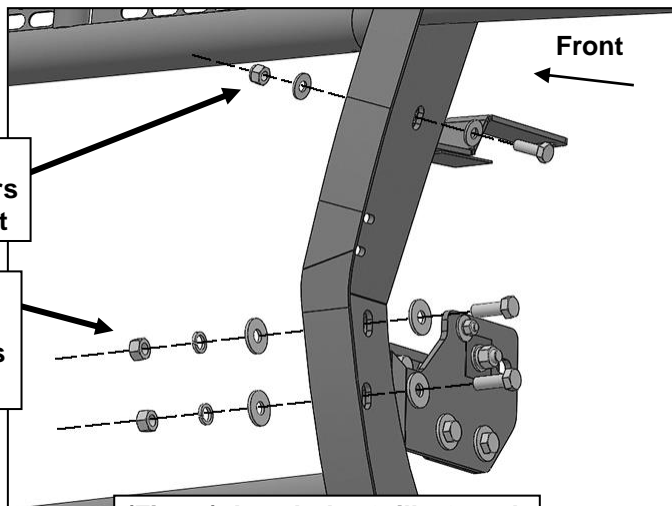

(Fig 14) Attach the Grille Guard to the Driver/Left Brackets

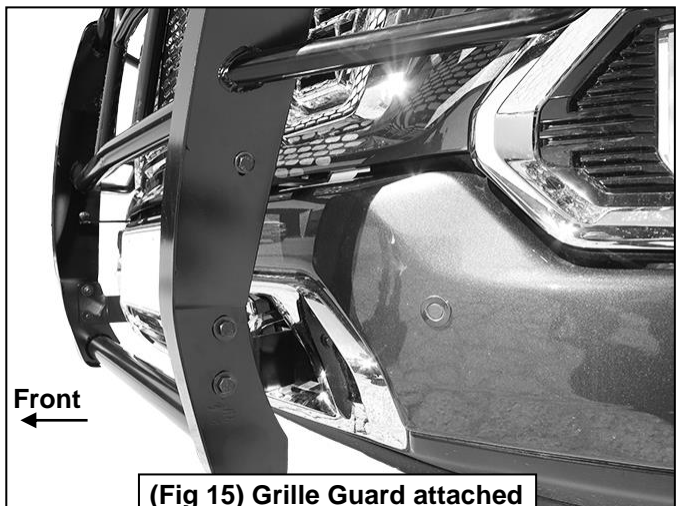

(Fig 15) Grille Guard attached to the Driver/Left Brackets

PRODUCT CARE

- Periodically check the product to ensure all fasteners are tight and components are intact.
- Regular waxing is recommended to protect the finish of the product.
- **Use ONLY Non-Abrasive automotive wax.** Use of any soap, polish or wax that contains an abrasive is detrimental and can scratch the finish leading to corrosion.
- Mild soap may be used to clean the **Black finish** product.

FAQ's**1. Hardware and mounting brackets are not aligning properly**

Ensure that hardware is being used on the correct side of the vehicle. In some cases, the hardware may appear same for driver or passenger side but may alter the alignment of mounting location. Check mounting brackets for both sides.

2. Grille Guard is not aligning with vehicle

Grille Guard Brackets may be interchanged or reversed (Driver / Passenger Side). Check Brackets for each side as well ensure the proper hardware has been used for each side.

3. Products are thumping / rattling after installation.

Ensure that all required mounting brackets / hardware's are installed & tighten correctly. Suggest using white lithium / regular grease between metal to metal contact.

4. Missing / Excess Hardware.

Recheck hardware count as per the part list.

5. Product not installing properly.

Ensure the Year / Make / Model as well as cab and bed dimensions are correct for the application. Review all steps for installation to ensure they were followed correctly.

6. Who should be contacted for questions regarding product / installation assistance?

www.trailfx.com / support@trailfx.com 1-(866) 638-4870

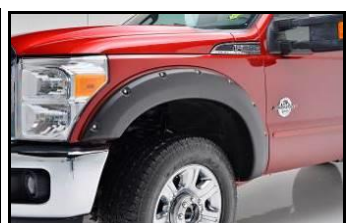
Check out these other TrailFX Products!www.trailfx.com**BED LINERS****OVAL STEP BARS****TONNEAU COVERS****FENDER FLARES**

Keystone Automotive Operations Inc. (KAO) warrants this product to be free of defects in material and workmanship at the time of purchase by the original retail consumer. KAO disclaims any other warranties, express or implied, including the warranty of fitness for a particular purpose or an intended use. If the product is found to be defective, KAO may replace or repair the product at our option, when the product is returned prepaid, with proof of purchase. Alteration to, improper installation, or misuse of this product voids the warranty. KAO's liability is limited to repair or replacement of products found to be defective, and specifically excludes liability for any incidental or consequential loss or damage.