

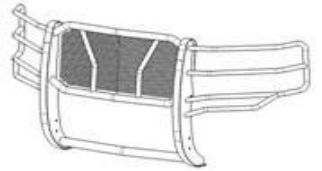

Extreme Grille Guard

Part No. E0518B



Fits: 2020-2020

GMC SIERRA 2500-3500



RATCHET, SOCKET SET AND WRENCH SET



REMOVE CONTENTS FROM BOX. VERIFY ALL PARTS ARE PRESENT



READ INSTRUCTIONS CAREFULLY BEFORE STARTING INSTALLATION

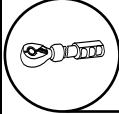

M10 BOLT 37 FOOT POUND
M12 BOLT 65 FOOT POUND



90 Mins



CUTTING May Be
REQUIRED



DRILLING NOT
REQUIRED



support@trailfx.com



1- (866) 638 - 4870



POWDER COATED BLACK – 3 YEARS

PARTS LIST:

Qty	Part Description	Qty	Part Description
1	HD Grille Guard	2	12mm x 24mm OD x 2.5mm STD Flat Washers
1	Driver/left Frame Bracket	6	12-1.75mm Nylon Lock Nuts
1	Passenger/Right Frame Bracket	4	10mm x 35mm Double Bolt Plates
1	Driver/left Frame Support Bracket	4	10-1.5mm x 130mm Hex Bolts
1	Passenger/right Frame Support Bracket	2	10-1.5mm x 35mm Hex Bolts
1	Driver/left Top Mounting Bracket	12	10mm x 27mm OD x 3mm Flat Washers
1	Passenger/Right Top Mounting Bracket	10	10-1.5mm Nylon Locknuts
6	12-1.75mm x 35mm Hex Bolts	1	2.5mm Wrench
10	12mm x 37mm OD x 3mm Large Flat Washers	2	Adhesive Backed Foam Tape Strips

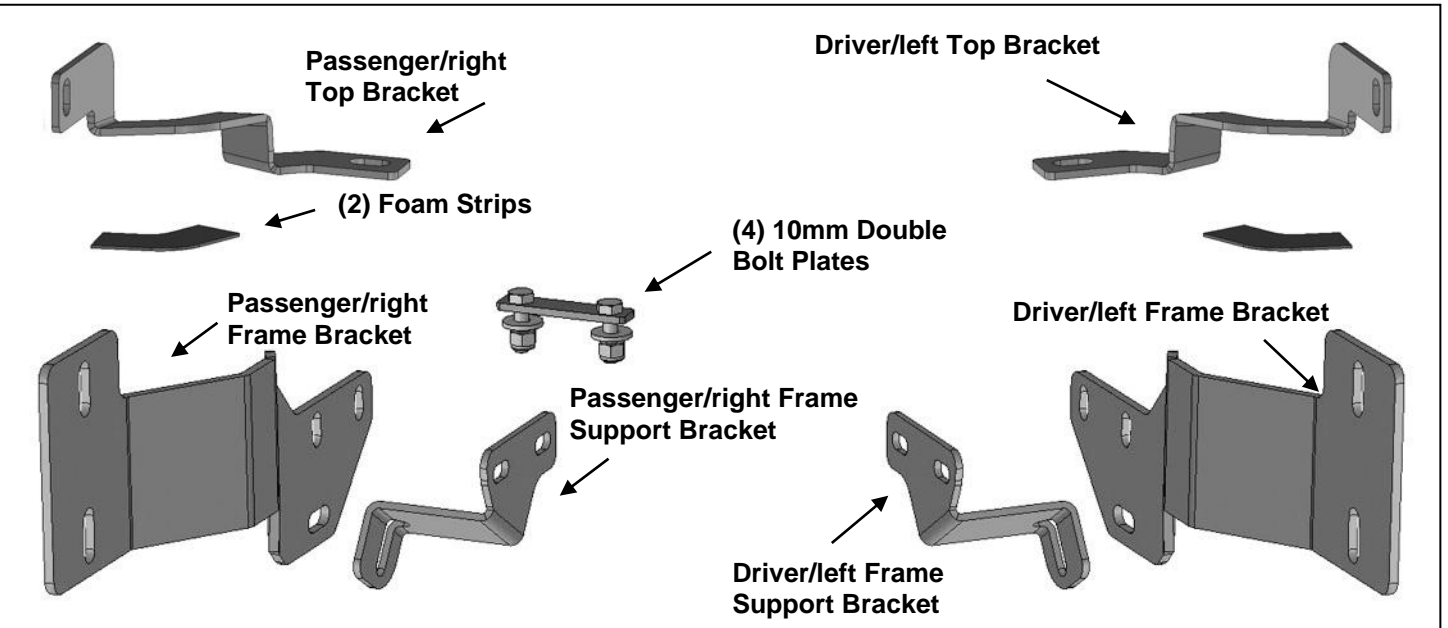

PROCEDURE:

REMOVE CONTENTS FROM BOX. VERIFY ALL PARTS ARE PRESENT. READ INSTRUCTIONS CAREFULLY BEFORE STARTING INSTALLATION. CUTTING MAY BE REQUIRED. INSTALLATION MAY INTERFERE WITH BUMPER MOUNTED PARKING SENSORS. ASSISTANCE IS RECOMMENDED.

1. Open the hood and remove the hood release handle, (Figures 1 & 2). Remove the plastic cover from the top of the grille and radiator. Temporarily reattach the handle.
2. Remove the hardware attaching the top of the grille to the body.

3. Loosen but do not remove the (2) plastic body panels, (fascia panels), between the top of the bumper and the bottom of the headlight, **(Figure 3)**, **NOTE**: Fascia panels do not need to be fully removed, only loosened to remove the grille.
4. On models with grille mounted camera, unplug harness leading to the camera.
5. Once all attaching screws and clips have been removed, pull grille straight out to release from clips, **(Figure 4)**.
6. Select the driver/left Top Bracket. Apply Foam Tape to bottom of the Bracket, **(Figure 5)**.
7. Remove the hex bolt from the top of the driver/left side of the frame, **(Figure 6)**. Use the factory hex bolt to attach the Top Bracket to the frame, **(Figure 7)**. Repeat this **Step** to attach the passenger/right Top Bracket. Do not fully tighten hardware at this time.
8. Move to the bottom of the front bumper. Determine if the vehicle is equipped with tow hooks.

Models with tow hooks.

- a. Remove the driver/left tow hook and seal from bumper, **(Figures 8—10)**. Slide tow hook back into position.
- b. Select the driver/left Frame Mounting Bracket and Support Bracket, **(Figure 11)**. Slide the Frame Bracket through the tow hook opening and along the outside of the frame, **(Figure 10)**. Insert (2) 10mm x 130mm Hex Bolts with (2) 10mm Flat Washers through the Bracket, frame and tow hook, **(Figures 11 & 12)**.
- c. Slide the Support Bracket over the hex bolts. Attach the Support Bracket to the inner facing side of the frame with (2) 10mm Flat Washers and (2) 10mm Nylon Lock Nuts, **(Figures 11 & 13)**. Do not fully tighten hardware at this time.
- d. Attach the bottom of the Support Bracket to the Frame Bracket with the included (1) 12mm x 35mm Hex Bolt, (1) 12mm x 37mm Large Flat Washer, (frame bracket side), (1) 12mm x 24mm Small Flat Washer, (support bracket side) and (1) 12mm Nylon Lock Nut, **(Figures 11 & 13)**. Do not fully tighten hardware at this time.
- e. Repeat these **Steps** to attach the passenger/right Brackets.

Models without tow hooks or if tow hooks will not be reinstalled

- a. **IMPORTANT**: The pocket in the plastic bumper may need to be cut out to clear the Frame Brackets, **(Figure 10)**. Use a sharp knife or hacksaw blade and carefully cut out the pocket to clear the Frame Brackets. Only cut out enough plastic to clear the Brackets.
 - b. Insert (1) 10mm Double Bolt Plate into the open end of the frame and out through the outside of the frame.
 - c. Slide the driver/left Frame Bracket through the opening in the bumper and over the threaded studs on the Bolt Plate, **(Figure 14)**.
 - d. Attach the Frame Bracket to the Bolt Plate with (2) 10mm Flat Washers and (2) 10mm Nylon Lock Nuts, **(Figure 14)**.
 - e. Repeat the previous **Steps** to attach the driver/left Support Bracket to the inner facing side of the frame, **(Figure 15)**. Attach the bottom of the Support Bracket to the Frame Bracket with the included (1) 12mm x 35mm Hex Bolt, (1) 12mm x 37mm Large Flat Washer, (frame bracket side), (1) 12mm x 24mm Small Flat Washer, (support bracket side) and (1) 12mm Nylon Lock Nut. Do not fully tighten hardware at this time.
 - f. Repeat these **Steps** to attach the passenger/right Brackets.
9. With assistance, position the Heavy Duty Grille Guard up to the outside of the Mounting Brackets, **(Figure 16)**. Attach the Grille Guard to the Frame Brackets with the included (4) 12mm x 35mm Hex Bolts, (8) 12mm x 37mm Large Flat Washers and (4) 12mm Nylon Lock Nuts, **(Figures 17 & 18)**. Attach the Top Brackets to the inside of the Grille Guard with (2) 10mm x 35mm Hex Bolts, (4) 10mm Flat Washers and (2) 10mm Nylon Lock Nuts, **(Figures 17 & 18)**. Do not fully tighten hardware.
 10. Level and adjust the Grille Guard and fully tighten all hardware attaching Brackets to vehicle only. Temporarily remove Grille Guard.
 11. Reinstall grille, fascia body panels and top cover. On models with camera, plug in wiring harness.
 12. Reinstall Grill Guard and fully tighten all hardware.
 13. On models with camera, remove screen from center of Grille Guard, **(Figure 19)**.
 14. Do periodic inspections to the installation to make sure that all hardware is secure and tight.

To protect your investment, Do not use any type of polish or wax that may contain abrasives that could damage the finish. Mild soap may be used to clean the Grille Guard.

Driver/left Side Installation Pictured



(Fig 1) Open hood and temporarily remove hood release handle

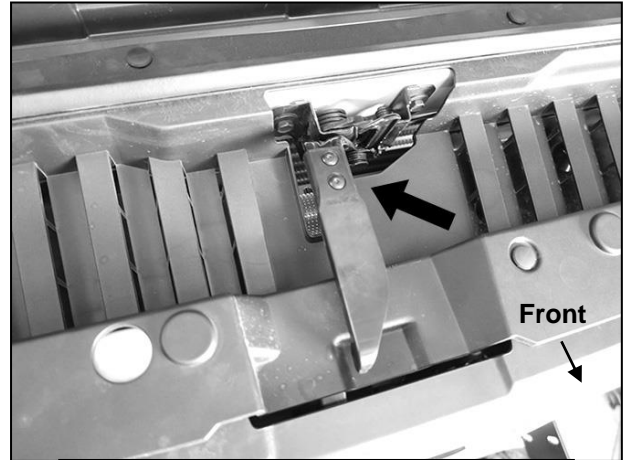

(Fig 2) Remove hood release lever (arrow). Remove plastic cover and temporarily reinstall the release lever

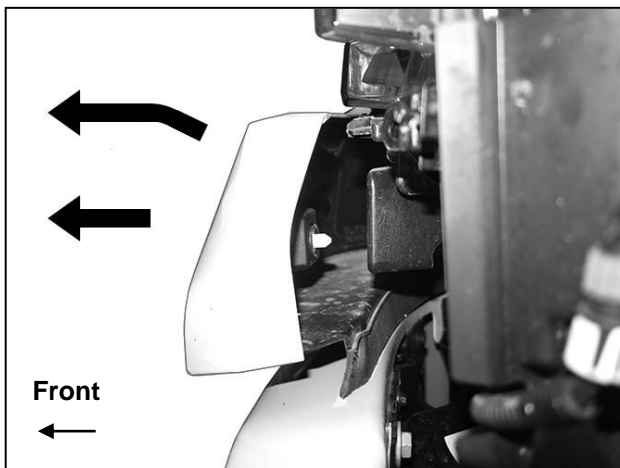

(Fig 3) Firmly pull fascia body panels up and straight out to release from clips (passenger side pictured-also see Figure 4)

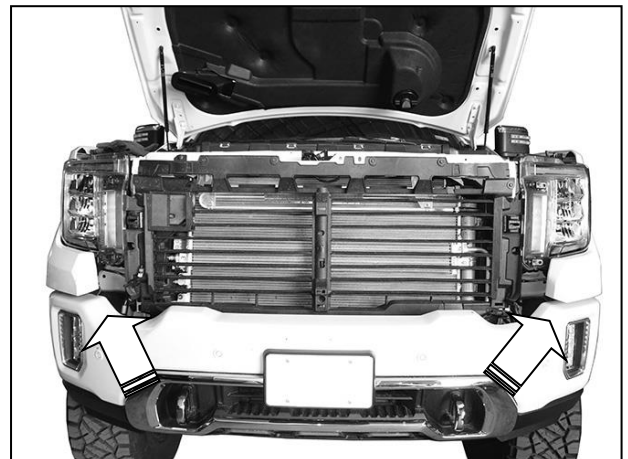

(Fig 4) Once both fascia body panels (arrows) have been loosened, remove grille

Driver/left Side Installation Pictured

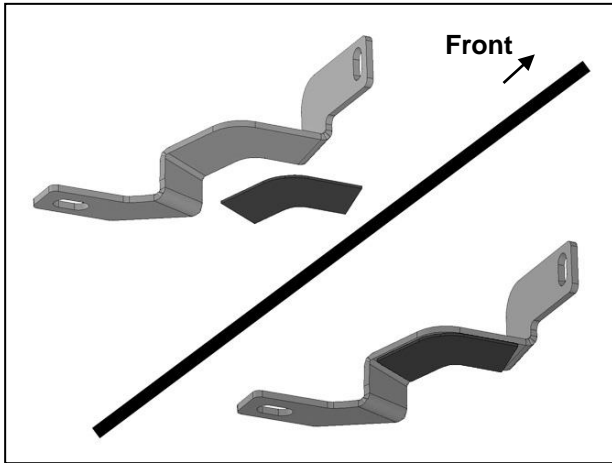

(Fig 5) Apply Foam Tape to bottom of the Top Brackets (driver/left Bracket illustrated)

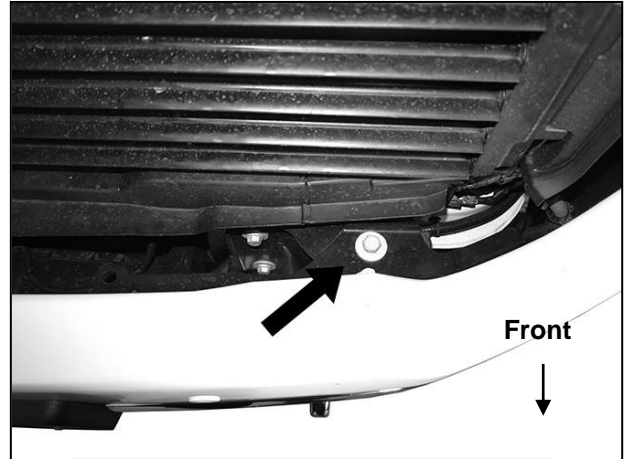

(Fig 6) From above, remove factory bumper bracket bolt (arrow)



(Fig 7) Reuse bumper bracket bolt to attach driver/left Top Bracket to top of frame

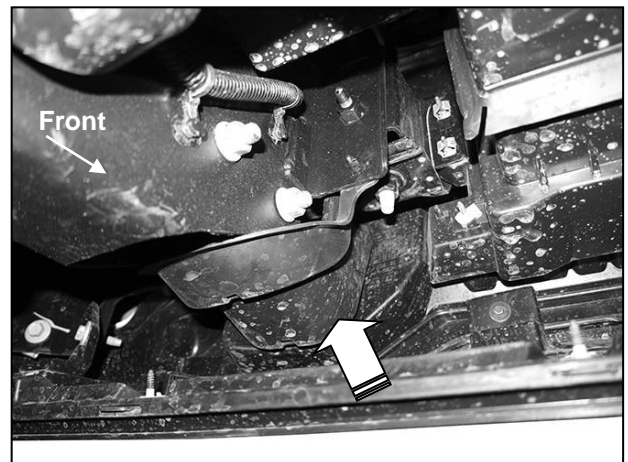

(Fig 8) Remove tow hook and foam seal (driver/left pictured from below)

Driver/left Side Installation Pictured

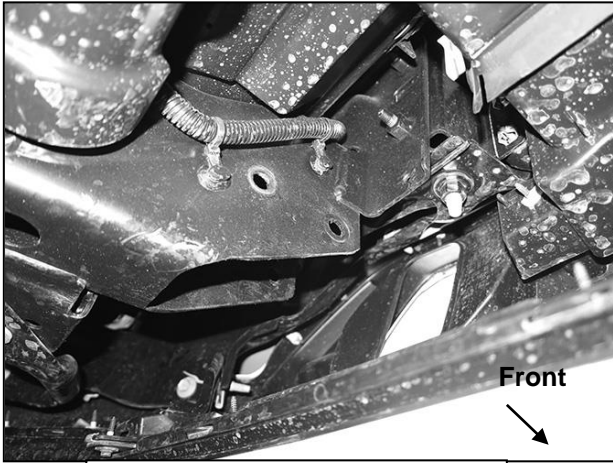

(Fig 9) Remove tow hook and foam seal (driver/left pictured)



(Fig 10) Reinsert tow hook. Insert driver/left outer Frame Bracket through opening and along outside of frame

- (2) 10mm x 130mm Hex Bolts
- (4) 10mm Flat Washers
- (2) 10mm Nylon Lock Nuts

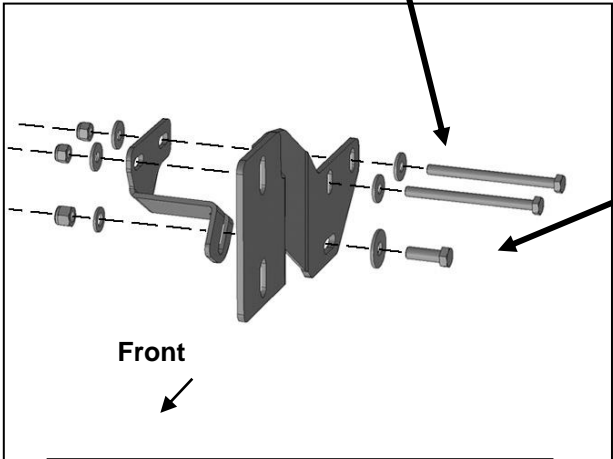

(Fig 11) Driver/left Frame Bracket and inner Support Bracket illustrated

- 12mm x 35mm Hex Bolt
- 12mm x 37mm Large Flat Washer
- 12mm x 24mm STD Flat Washer
- 12mm Nylon Lock Nut

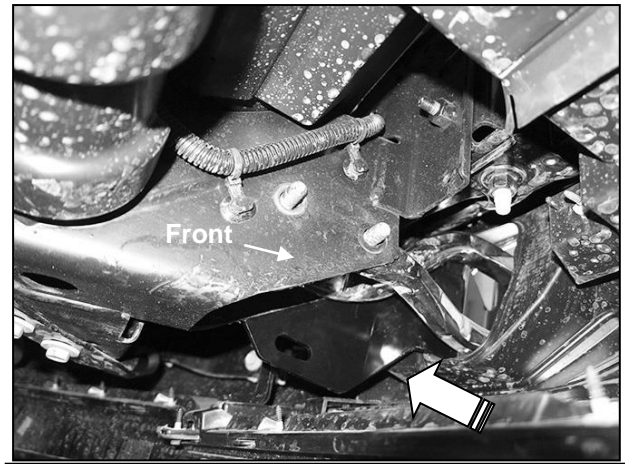

(Fig 12) Attach driver/left Frame Bracket to outside of frame (pictured from below bumper)

Driver/left Side Installation Pictured

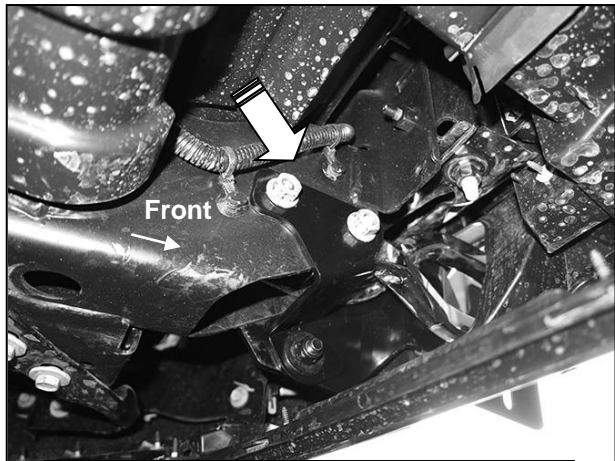

(Fig 13) Attach driver/left inner Support Bracket to inner facing side of frame

- 10mm Double Bolt Plate
- (2) 10mm Flat Washers
- (2) 10mm Nylon Lock Nuts

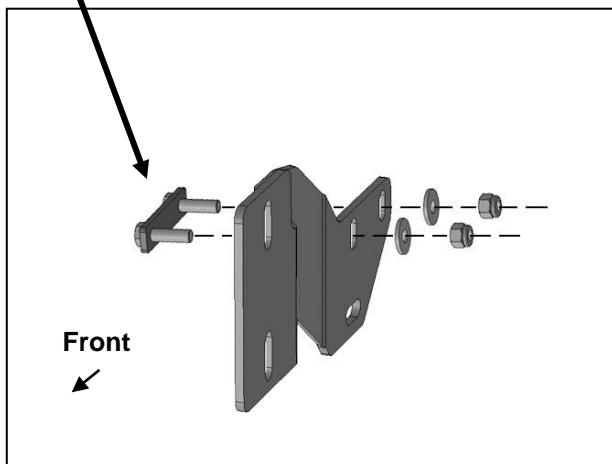

(Fig 14) Models without tow hooks, insert Double Bolt Plate into frame and out through holes. Attach driver/left Frame Bracket to Double Bolt Plate

- 10mm Double Bolt Plate
- (2) 10mm Flat Washers
- (2) 10mm Nylon Lock Nuts

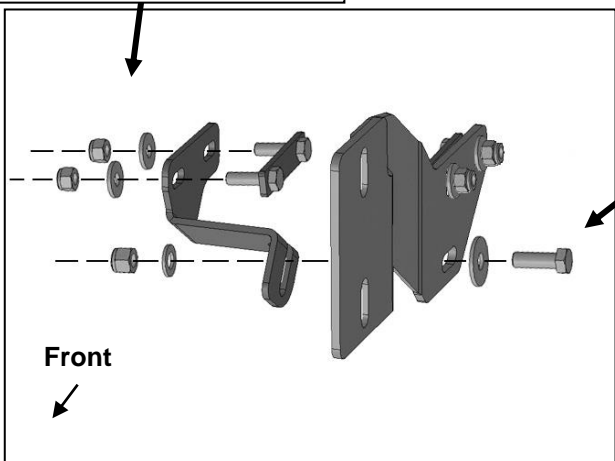

(Fig 15) Models without tow hooks, insert Double Bolt Plate into frame and out through holes. Attach driver/left inner Support Bracket to Double Bolt Plate. Attach Support Bracket to bottom of Frame Bracket

- 12mm x 35mm Hex Bolt
- 12mm x 37mm Large Flat Washer
- 12mm x 24mm STD Flat Washer
- 12mm Nylon Lock Nut

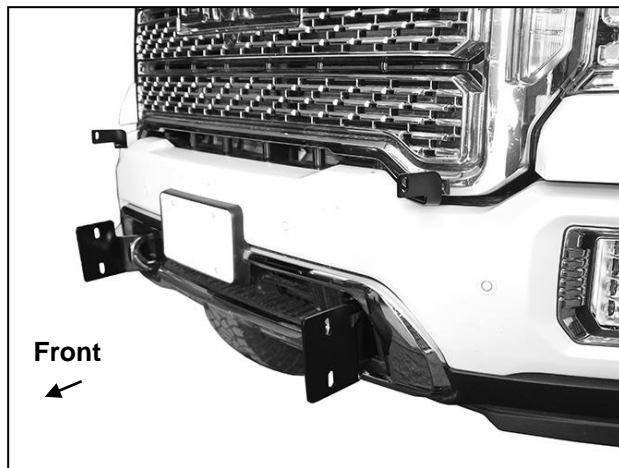

(Fig 16) Brackets installed. Do not reinstall grille until after Grille Guard has been installed, Brackets adjusted and hardware tightened to frame only (Step 10, Fig 18)

Driver/left Side Installation Pictured

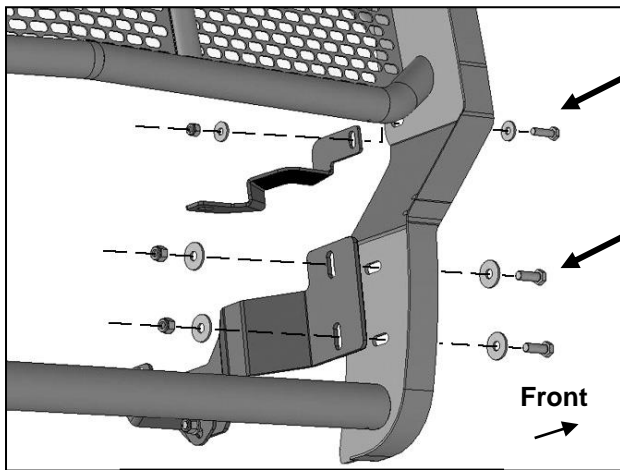

10mm x 35mm Hex Bolt
(2) 10mm Flat Washers
10mm Nylon Lock Nut

(2) 12mm x 35mm Hex Bolts
(4) 12mm Flat Washers
(2) 12mm Nylon Lock Nuts

(Fig 17) Attach Grille Guard to outside of Brackets



(Fig 18) Grille Guard installed (driver/left side pictured)

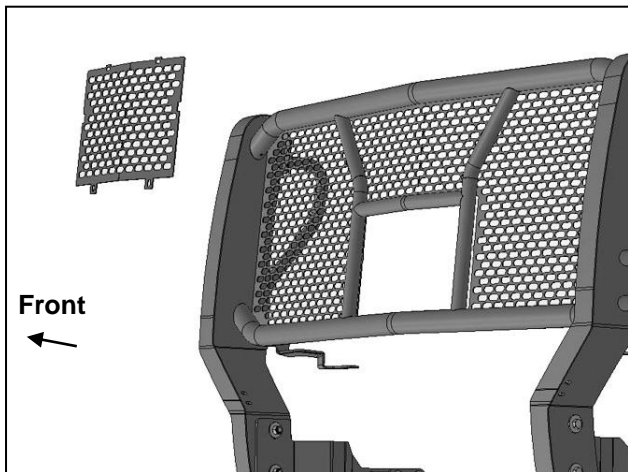

(Fig 19) Models with grille mounted camera, remove screen from Grille Guard



PRODUCT CARE

- Periodically check the product to ensure all fasteners are tight and components are intact.
- Regular waxing is recommended to protect the finish of the product.
- **Use ONLY Non-Abrasive automotive wax.** Use of any soap, polish or wax that contains an abrasive is detrimental and can scratch the finish leading to corrosion.
- Mild soap may be used to clean the **Black finish** product.

FAQ's**1. Hardware and mounting brackets are not aligning properly**

Ensure that hardware is being used on the correct side of the vehicle. In some cases, the hardware may appear same for driver or passenger side but may alter the alignment of mounting location. Check mounting brackets for both sides.

2. Grille Guard is not aligning with vehicle

Grille Guard Brackets may be interchanged or reversed (Driver / Passenger Side). Check Brackets for each side as well ensure the proper hardware has been used for each side.

3. Products are thumping / rattling after installation.

Ensure that all required mounting brackets / hardware's are installed & tighten correctly. Suggest using white lithium / regular grease between metal to metal contact.

4. Missing / Excess Hardware.

Recheck hardware count as per the part list.

5. Product not installing properly.

Ensure the Year / Make / Model as well as cab and bed dimensions are correct for the application. Review all steps for installation to ensure they were followed correctly.

6. Who should be contacted for questions regarding product / installation assistance?

www.trailfx.com / support@trailfx.com 1-(866) 638-4870

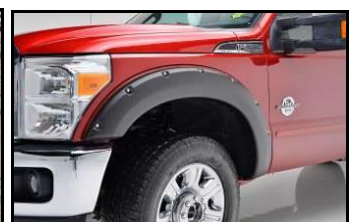
Check out these other TrailFX Products!www.trailfx.com**BED LINERS****OVAL STEP BARS****TONNEAU COVERS****FENDER FLARES**

Keystone Automotive Operations Inc. (KAO) warrants this product to be free of defects in material and workmanship at the time of purchase by the original retail consumer. KAO disclaims any other warranties, express or implied, including the warranty of fitness for a particular purpose or an intended use. If the product is found to be defective, KAO may replace or repair the product at our option, when the product is returned prepaid, with proof of purchase. Alteration to, improper installation, or misuse of this product voids the warranty. KAO's liability is limited to repair or replacement of products found to be defective, and specifically excludes liability for any incidental or consequential loss or damage.