

FORD F-SERIES STYLESIDE & FLARESIDE INSTALLATION INSTRUCTIONS

1. Installation Preparation

PLEASE READ ENTIRE INSTALLATION INSTRUCTION SHEET BEFORE BEGINNING INSTALLATION. Improper installation may void warranty.

WARNING: Do not transport a pick up truck facing backward with a liner installed. Air can get under the liner which may result in the liner coming out of the truck and causing damage or injury.

Truck Box Preparation:

Clean truck box of all foreign matter and open any floor drains to ensure ventilation and moisture drainage.

Tools Required:

Phillips Screwdriver, Power Screwdriver with Phillips Bit, T30 Torx Head Driver, Drill with 3/8" Bit.

Note:

Bedliner can be installed by one person. However, using two people is recommended by the manufacturer.

2. F150 Flareside & F250/350 Tailgate Cover Installation Steps

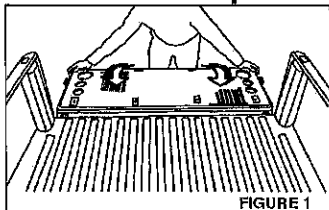

FIGURE 1

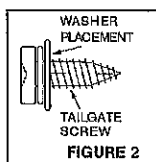

FIGURE 2

NOTE: Your tailgate cover kit may have more or less hardware than shown.

STEP 1

Center tailgate cover on truck tailgate, locating any factory screws at predrilled hole locations. Remove these screws and set aside for later use. (See FIGURE 1)

STEP 2

Place washers on screws previously removed. (See FIGURE 2) Reinstall screws with washers and tighten down tailgate cover.

2a. F150 Styleside Tailgate Cover Installation Steps

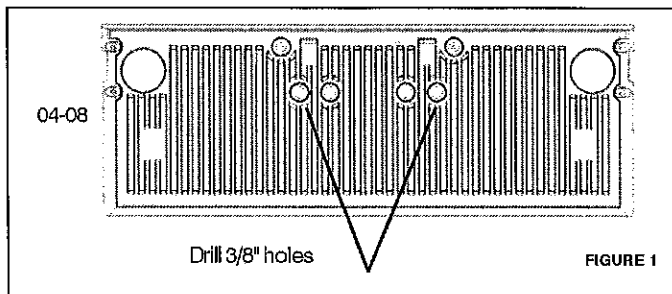

FIGURE 1

STEP 1

Center tailgate cover on truck tailgate, locating any factory screws at predrilled hole locations. Remove these screws and set aside for later use.

STEP 2

Drill two (2) outer holes (Figure 1) for 04-08 MY. Drill two (2) inner holes for 09+ MY. (Figure 2)

STEP 3

Place washers on screws previously removed. Reinstall screws with washers and tighten down tailgate cover.

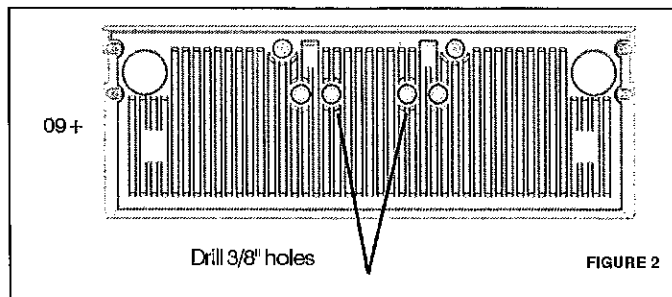
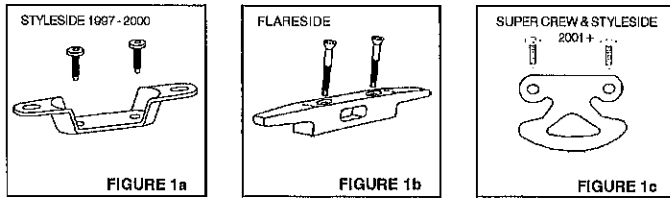

FIGURE 2

Manufactured by:

PENDA CORPORATION • P.O. Box 449, 2344 W. Wisconsin St., Portage, WI 53901-0449
(800) 356-7704 • (800) 362-7611 (In Wisconsin) • (Internet) www.penda.com

3. Bedliner Installation Steps - Ford: F-150 1997+



Note: Some liners come with a large diameter tie down access hole in the rear sidewall. On these liners the rear tie down brackets do not need to be removed to install the bedliner.

STEP 1

Using a T30 Torx Head Driver, remove screws from the rear cargo tie-downs located in truckbox sidewalls. Set the screws and the tie-downs aside for later use (See FIGURE 1a or 1b or 1c).

STEP 2

Place bedliner in truck box. While standing beside truck box at approximately the center of the box area, lift side of bedliner up at a 45° angle so that the opposite side slips under the siderail of pickup truck (See FIGURE 2). A second person may be required to help slip the wall of the bedliner under the sidewall of the truck box.

(NOTE: Front rail lip must be over front rail of truck bed.)

STEP 3

Stand at rear of pickup (center) and lift bedliner floor up. Have second person push bedliner wall under the siderail of the pickup truck (See FIGURE 3). Release bedliner floor (making sure front rail lip is entirely over front rail of truck box).

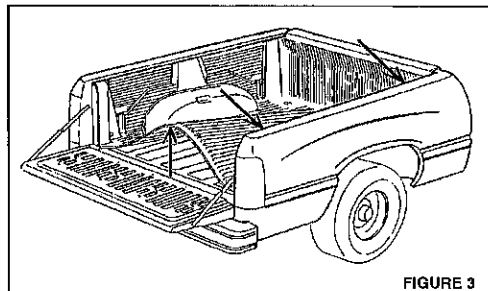
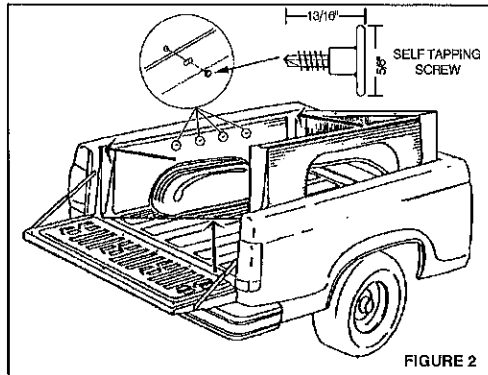

**FOR SUPER CREW CAB VEHICLES 2001 - 2003 ONLY
IF THIS DOES NOT APPLY, GO TO STEP 6.**

STEP 4

Insert screw through slots in bedliner and fasten down. (4 locations per side)

STEP 5

Repeat this process for all screw slot locations on the opposite side wall (See FIGURE 2).

STEP 6

Adjust bedliner position so that the holes in the rear sidewall pockets lineup to the rear cargo tie-down holes in the truckbox. To attach the rear cargo tie-downs on the styleside, use the 4 longer screws if provided in the kit. For the flareside or Super Crew, reinstall the rear cargo tie-downs with the 4 screws removed in STEP 1 (See FIGURE 1b or 1c).

4. Under Rail Bedliner Installation Steps -

Ford: F-150 '87-'96; F-250/350 '99+; Ranger/Mazda '93+; Toyota Tundra; Toyota Tacoma.

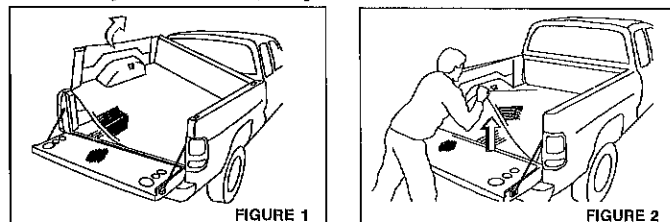

(NOTE: Some bedliners may not have front rail lip. These require two (2) screws to secure front wall.)

CAUTION: It is recommended that two (2) people install the bedliner to avoid damage to the painted surface of the truck.

STEP 1 (Figure 1)

Place bedliner in the truck bed, such that the front rail retainer fits over the front rail of the truck bed. While standing on the side of the truck, lift one side of the bedliner and slip the sidewall of the bedliner under the opposite wall of truck box.

STEP 2 (Figure 2)

While standing at the rear of the truck, lift the bedliner floor in the center. (Figure 2) This procedure allows the bedliner sidewall to rotate away from the bed rail. Have a 2nd person slip/lock the bedliner sidewall in position by applying a downward force. **NOTE:** Make sure that the raised liner locking tabs on the sidewalls are secured behind and under the side rail sheet metal of the truck box.

STEP 3

Check the overall fit. It is important that the bedliner fits securely in place under the bed rails. If necessary, repeat steps 2 & 3.