



NISSAN BEDLINER/TAILGATE COVER



Part No. TG60X



Do not over tighten as screws can be stripped out.



30-60 min

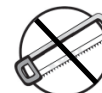

CUTTING NOT REQUIRED



DRILLING REQUIRED



REMOVE CONTENTS FROM BOX. VERIFY ALL PARTS ARE PRESENT.



support@trailfx.com



READ INSTRUCTIONS CAREFULLY BEFORE STARTING INSTALLATION.



1 866 638 4870

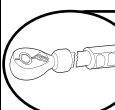

DO NOT OVER TORQUE. STANDARD OPERATING LOAD FOR TIGHTEN BODY MOUNT NUTS & BOLTS VARIES FROM 45 TO 65 FOOT POUND.



Limited Lifetime

Tools Required

Phillips Screwdriver,

Power Screwdriver with Phillips Bit,

1. INSTALLATION PROCEDURE:

WARNING:

- Do not transport a pickup truck facing backward with a liner installed.
- Air can get under the liner which may result in the liner coming out of the truck and causing damage or injury.

Truck Box Preparation:

- Clean truck box of all foreign matter and open any floor drains to ensure ventilation and moisture drainage.

NOTE:

- Bed liner can be installed by one person. However, using two people is recommended by the manufacturer.

2. Tailgate Cover Installation Steps

NOTE: Your tailgate cover kit may have more or less hardware than shown.

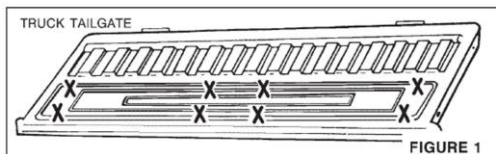

FIGURE 1

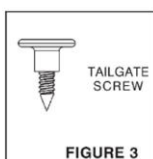

FIGURE 3

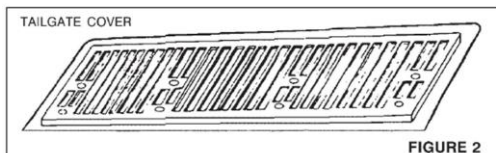

FIGURE 2

STEP1:

Remove 8 (eight) existing factory installed tailgate screws (Designated by "X" in FIGURE 1) and discard them.

STEP2

Using the screws provided in kit (See FIGURE 2), fasten tailgate cover to truck tailgate using a Phillips screwdriver. **DO NOT OVERTIGHTEN.** Plastic nut inserts on truck tailgate will easily strip out.

STEP3

Repeat Step 2 to remaining hole locations until all are completed.

Do not over tighten as screws can be stripped out.

3. Under Rail Bedliner Installation Steps

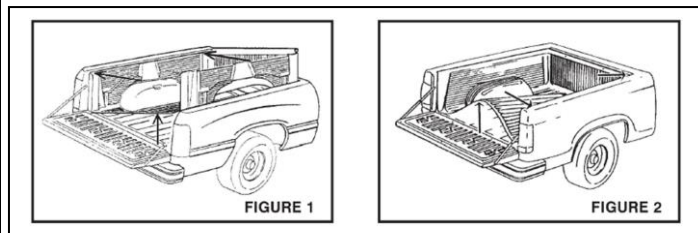

(NOTE: Some bedliners may not have front rail lip.)

STEP 1

Place bedliner in truck box. While standing beside truck at approximately the center of box area, lift side of bedliner up at a 45° angle so that the opposite side slips under the siderail of pickup truck (See FIGURE 1). A second person may be required to help slip the wall of the bedliner under the sidewall of the truck box.

STEP 2

Stand at rear of pickup (center) and lift bedliner floor up. Have a second person push bedliner wall under siderail of the pickup truck (See FIGURE 2). Release bedliner floor.

4. Overrail Bedliner Installation Steps

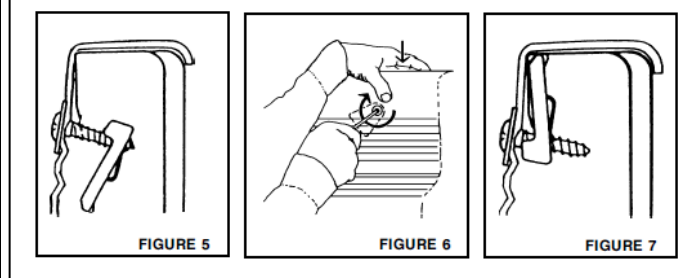
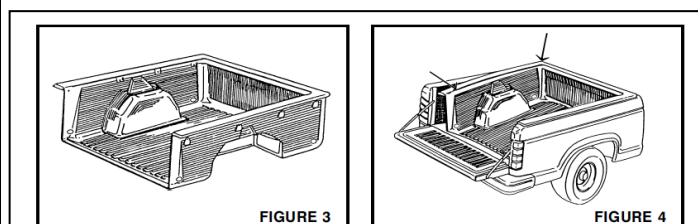
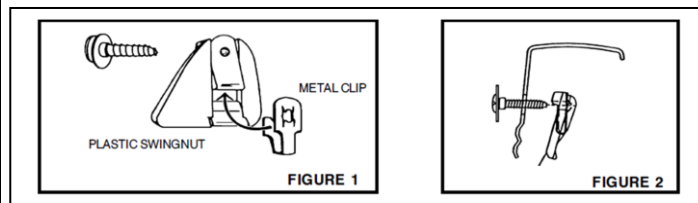

STEP 1

With the Bedliner Out Of Truck:

1. Assemble "Liner-Lok™" fasteners by sliding metal clip onto plastic swingnut (see FIGURE 1).
2. Insert screw through hole provided in bedliner side wall, with head of screw toward inside of truck bed.
3. Position "Liner-Lok™" fastener with side "A" towards screw tip (see FIGURE 2).
4. Insert screw tip into hole and metal clip of fastener and turn one or two rotations, or until tip of screw is engaged into fastener.

IMPORTANT: The "Liner-Lok™" must be in a loose down ward hanging position at this time. (see FIGURE 5)

5. Repeat "Liner-Lok™" fastener assembly to remaining holes.

STEP 2

Place bedliner with loosely hanging "Liner-Lok™" fasteners into truckbox. Pull the bedliner rails away from truck rails and push downward starting at front corner, until forward "Liner-Loks™" slip under the truck rails. Make certain that all "Liner-Lok™" fasteners have slipped under the truck rails before tightening (see FIGURES 3, 4 & 5).

STEP 3

Close tailgate. Adjust bedliner if needed.

STEP 4

Standing or kneeling on bedliner in truck box:

1. Start at either front (cab end) corner and push downward on bedliner rail while turning screw clockwise with screw driver (see FIGURE 6). You should "feel" the "Liner-Lok™" pivot upwards and stop. Continue turning the screw clockwise until tight (see FIGURE 7).
2. Move to opposite corner and repeat step 4 - 1.
3. Repeat step 4 - 1 to remaining "Liner-Loks™".



NISSAN DOUBLURE DE BOÎTE/HAYON



Part No. TG60X

Outils nécessaires :

Tournevis Phillips,

Tournevis Électrique avec Mèche Phillips

1. Préparation pour installation

AVERTISSEMENT:

- Ne transportez pas, dans le sens contraire de la marche, un camion équipé d'une doublure de caisse.
- De l'air peut pénétrer sous la doublure qui risque alors de se détacher et de causer des dommages ou des blessures.

Préparation de la benne du pick-up:

- Lavez la benne du pick-up et ouvrez les drains au sol afin d'assurer une bonne ventilation et l'élimination de l'humidité.

NOTE:

- La doublure peut être installée par une seule personne. Cependant, le fabricant recommande qu'elle le soit par deux.

2. Pose De La Doublure De Hayon

NOTE: Votre kit de couverture du hayon peut avoir plus ou moins de matériel que montré.

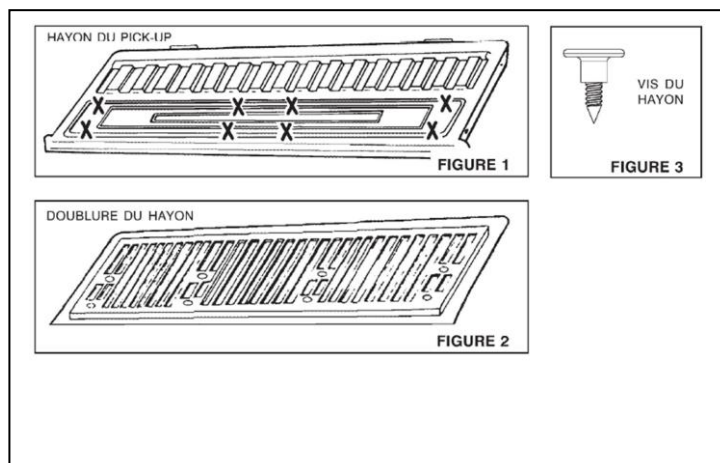

ÉTAPE 1

Enlevez les huit (8) vis de la porte à rabattement arrière installées dans l'usine (indiquées par "X" sur la figure 1) et les jetez.

ÉTAPE 2

Utilisant les vis fournies dans le kit (voir FIGURE 2), avec l'aide d'un tournevis Philips, attache la couverture de hayon à la porte de hayon du camion. NE PAS TROP SERREZ. Les rondelles en plastique sur le hayon de camion dépouilleront facilement.

ÉTAPE 3

Repetez l'Étape 2 pour les trous restants jusqu'à ce que tous les trous soient munis de vis.

3. Doublure de caisse à poser sous les longerons *(NOTE: Quelques doublure de caisses peuvent ne pas avoir la lèvre avant de rail.)*

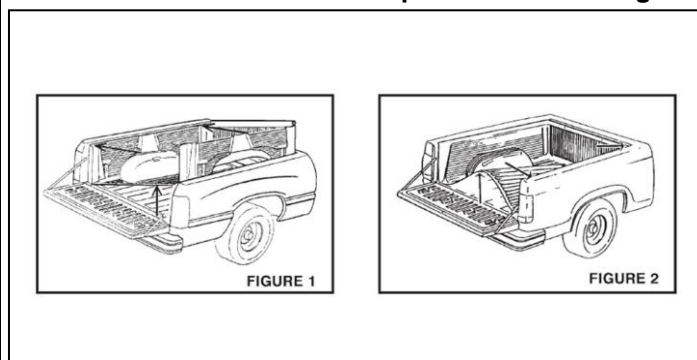

ÉTAPE 1

Placez la doublure du plateau dans la benne du pick-up. Debout, à côté du pick-up et à proximité du centre de la benne, levez le côté de la doublure du plateau selon un angle de 45° de façon à ce que le côté opposé glisse en dessous de la paroi latérale du pick-up (voir FIGURE 1). Une deuxième personne peut être nécessaire pour aider à glisser la paroi de la doublure du plateau en dessous de la paroi latérale de la benne du pick-up.

ÉTAPE 2

Debout, à l'arrière du pick-up (centre), relevez le plancher de la doublure du plateau. La deuxième personne doit alors pousser la paroi de la doublure du plateau en dessous de la paroi latérale du pick-up (voir FIGURE 2). Lâchez le plancher de la doublure du plateau.

4. Doublure de caisse avec rebord

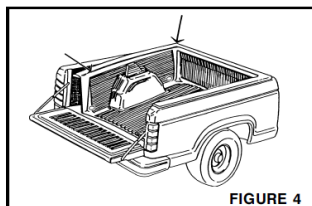
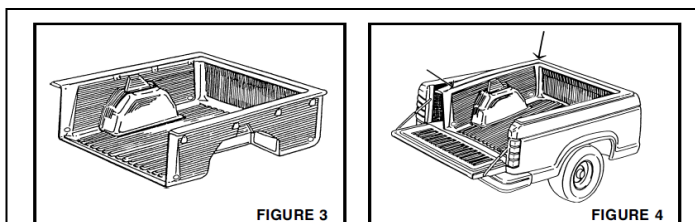
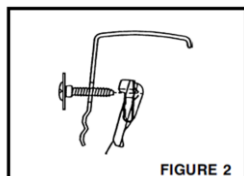
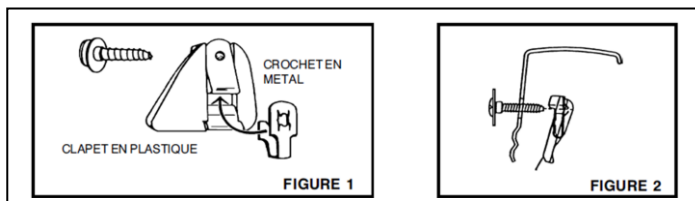

ÉTAPE 1

Avant de poser la doublure dans le camion:

1. Assembler les attaches "Liner-Lok" en glissant le crochet en métal dans le clapet en plastique (voir fig. 1)
2. Insérer la vis à travers le trou prévu à cet effet dans le côté de la doublure, la tête de la vis se trouvant à l'intérieur de la caisse du camion.
3. Positionner et visser les attaches "Liner-Lok" comme illustré en fig.2.
4. Insérer la pointe de la vis dans le trou de la doublure et dans le crochet en métal de l'attache et visser d'une ou de deux rotations, jusqu'à ce que la pointe de la vis soit engagée dans l'attache. IMPORTANT: le "Liner-Lok" doit pendre et ne doit pas être serré à ce moment précis de l'opération (voir fig. 2).
5. Répéter l'opération sur tous les espaces découpés restants.

ÉTAPE 2

Placer la doublure avec les attaches "Liner-Lok" dans la caisse du camion. Faire glisser les attaches "Liner-Lok" sous les longerons du camion en commençant par le côté cabine de la caisse. S'assurer que toutes les attaches ont bien glissé sous les longerons avant de les fixer (voir fig. 3,4, & 5).

ÉTAPE 3

Fermer le hayon. Ajuster la doublure si besoin.

ÉTAPE 4

Monter dans la caisse du camion.

1. Commencer par le côté cabine de la caisse. Pousser le longeron de la doublure contre le rebord de la caisse en serrant la vis de l'attache "Liner-Lok" dans le sens des aiguilles d'une montre (voir fig. 6). Vous devrez "sentir" le "Liner-Lok" pivoter vers le haut et s'arrêter. Continuer à serrer la vis jusqu'à ce que la doublure soit bien fixée à la caisse du camion (voir fig 7).
2. Passer au côté opposé et répéter l'opération.
3. Répéter l'opération pour tous les "Liner-Lok" restants.

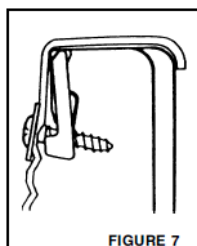
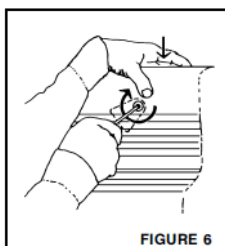
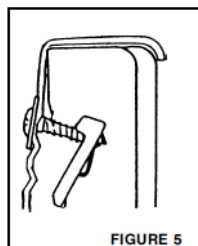



CUBIERTA DE NISSAN BEDLINER/TAILGATE



Part No. TG60X

Herramientas necesarias:

Destornillador Phillips,

Destornillador electrico con el pedacito Phillips

1. Preparacion para la instalacion

ADVERTENCIA:

- No transporte una camioneta apuntando hacia atras con un forro instalado.
- Se puede meter aire debajo del forro, lo cual puede hacer que el forro se despegue de la camioneta y ocasione

Preparacion de la caja de la camioneta:

Limpie la caja de la camioneta de toda materia extrana y abra los desagues del piso para asegurar la ventilacion y el drenaje de la humedad.

NOTA:

El forro puede instalarlo una sola persona. Sin embargo, el fabricante recomienda que lo hagan dos personas.

2. Pasos de instalaci6n de la cubierta de la compuerta trasera

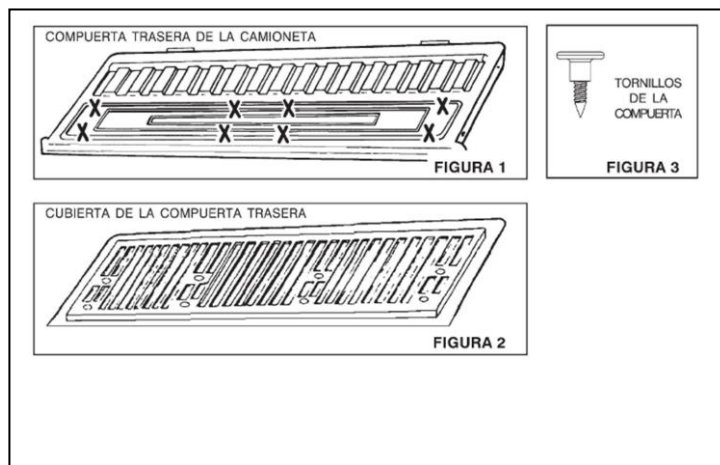

PAS01

Quite los (8) ocho tornillos que vienen instalados de fabrica en la compuerta de la camioneta (Representados con una "X" en la Figura 1) y deseche los.

PAS02

Utilizando los tornillos que se incluyen en el juego (Vea la FIGURA2), instale la cubierta en la compuerta trasera de la camioneta usando un destornillador Phillips. **NO APRIETE EN EXCESO.** Las inserciones de plastico de las tuercas de la compuerta trasera de la camioneta se danan facilmente.

PAS03

Repita el Paso 2 con los agujeros restantes hasta terminar con todos.

3. Debajo del arrastre del forro de la caja

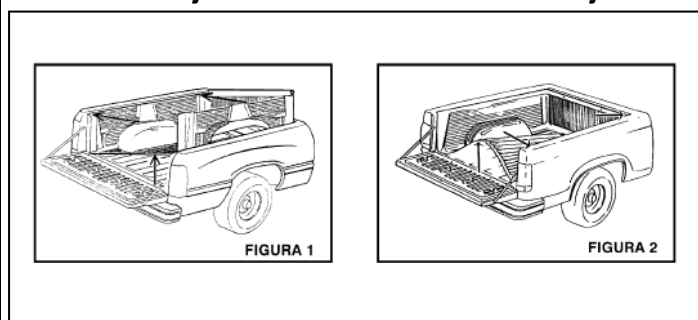

(Nota: Algunos bed liners pueden no tener lengüeta delantera para la baranda. Los detalles By C para el sujetador trasero nose aplican a todos los modelos.)

PAS01

Coloque el forro en la caja de la camioneta. Cuando este parado allado de la camioneta aproximadamente en el centro del area de la caja, levante el lado del forro a un angulo de 45° de modo que ellado opuesto se deslice debajo de la baranda lateral de la camioneta (Vea la FIGURA 1). Es posible que necesite la ayuda de una segunda persona para deslizar la pared del forro debajo de la pared lateral de la caja de la camioneta.

PAS02

Parese detras de la camioneta (en el centro) y levante el piso del forro hacia arriba. Haga que una segunda persona empuje la pared del forro bajo la baranda lateral de la camioneta (Vea la FIGURA 2). Suelte el piso del forro.

4. Bedliner Sobre El Riel

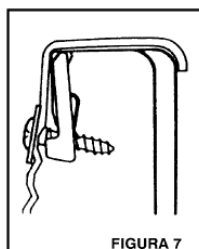
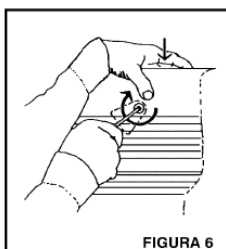
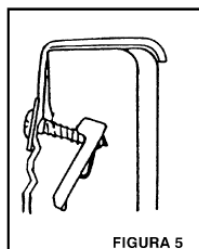
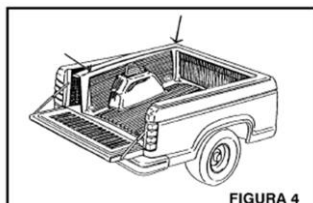
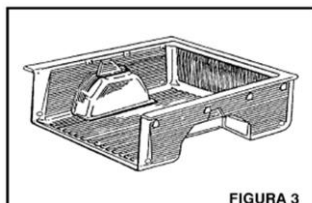
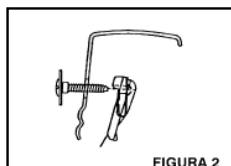
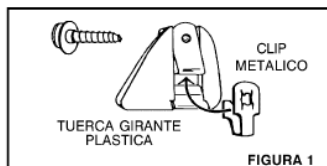

PAS01

Con el Bed liner fuera de la caja de la camioneta:

1. Monte los sujetadores del Bed liner "Liner-Lok", deslizando el clip metálico sobre la tuerca girante plástica (Vea Figura 1).
2. Inserte los tornillos a través de los orificios provistos en la pared del Bed liner, con la cabeza del tornillo hacia el interior de la caja de la camioneta.
3. Coloque el tornillo y el sujetador como se ve en la figura 2.
4. Inserte la punta del tornillo en el clip metálico y gire una o dos vueltas para que se engarse en el clip, **IMPORTANTE:** El clip metálico debe estar flojo y en posición olgando hacia abajo (Vea Figura 2).
5. Repita la montadura de los sujetadores "Liner-Lok" para el resto de los orificios provistos en la pared del Bed liner.

PAS02

Coloque el bed liner dentro de la caja con los sujetadores sueltos. Aleje los rieles del Bedliner de los rieles de la camioneta y empuje las esquinas hacia abajo empezando con las esquinas frontales de la camioneta. Asegurese que todos los sujetadores se han deslizado debajo de los rieles de la camioneta antes de apretar los tornillos. (Vea Figuras 3, 4 & 5).

PAS03

Cierre la compuerta y ajuste el Bedliner si es necesario.

PAS04

Parada o arrodillado en el Bed liner dentro de la caja de la camioneta:

1. Empiece de cualquier esquina frontal y empuje el Bed liner hacia abajo y con el desarmador apriete el tornillo en el sentido de las manecillas del reloj (Vea Figura 6) Debera sentir que el sujetador dejara de pivotar y se detenga, continúe apretando que se apriete (Vea Figura 7).
2. Muevase a la esquina contraria y repita el paso 4-1
3. Repita el paso 4-1 para el resto de los Sujetadores.

PRODUCT CARE

- Sweep any dirt and debris out of the bed of the truck. Pick up any items that may scratch the liner, such as rocks or large sticks.
- Inspect Bed liner on frequent basis to identify any damages.
- Clean the product with mild soap / cleaner to remove stains.
- While washing Rinse bed and tailgate thoroughly until no soap runs off the truck.

FAQ's

- 1. Will the bed feel hotter than the rest of the truck?**
No, protective coating shall help to keep it cooler than truck.
- 2. Protective coating is used as an undercoating?**
Yes, it can be used.
- 3. Is protective coating environmentally friendly?**
Yes, there is no possible health hazard and it is environment friendly
- 4. Can I take it out Protective Coating?**
No, Protective coating is a permanent coating and can't be removed.
- 5. Does the lining require special maintenance?**
No, it can be cleaned up with mild soap.
- 6. Missing / Excess Hardware.**
Recheck hardware count as per the part list.
- 7. Product not installing properly.**
Ensure make model year, cab length and bed size of your vehicle is listed in the application. All installation steps are followed correctly.

Check out these other TrailFX Products!!

www.TrailFX.com



SIDE BARS



ROCKER GUARD



BED RAILS



RUNNING BOARDS

Keystone Automotive Operations Inc. (KAO) warrants this product to be free of defects in material and workmanship at the time of purchase by the original retail consumer. KAO disclaims any other warranties, express or implied, including the warranty of fitness for a particular purpose or an intended use. If the product is found to be defective, KAO may replace or repair the product at our option, when the product is returned prepaid, with proof of purchase. Alteration to, improper installation, or misuse of this product voids the warranty. KAO's liability is limited to repair or replacement of products found to be defective, and specifically excludes liability for any incidental or consequential loss or damage.