



DODGE DAKOTA UNDER RAIL BEDLINER



Part No. 22108X, TG53X



Do not over tighten as screws can be stripped out.



30-60 min



CUTTING NOT
REQUIRED



DRILLING
REQUIRED



REMOVE CONTENTS FROM BOX. VERIFY ALL PARTS ARE PRESENT.



support@trailfx.com



READ INSTRUCTIONS CAREFULLY BEFORE STARTING INSTALLATION.



1 866 638 4870

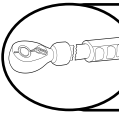

DO NOT OVER TORQUE. STANDARD OPERATING LOAD FOR TIGHTEN BODY MOUNT NUTS & BOLTS VARIES FROM 45 TO 65 FOOT POUND.



Limited Lifetime

Tools Required

Phillips Screw Driver (For Securing Screws in Scrivets)

1. INSTALLATION PROCEDURE:

Verify Kit Contents:

DODGE DAKOTA UNDER RAIL BEDLINER		
Description	Qty.	Kit Contents:
Under Rail Bedliner	1	10 Scrivets,
Tailgate Cover	1	2 Tie Down Hole Plugs (Short Bed Only),
Installation Kit	1	Installation Instruction Sheet

2. Tailgate Cover Installation Steps with Screws

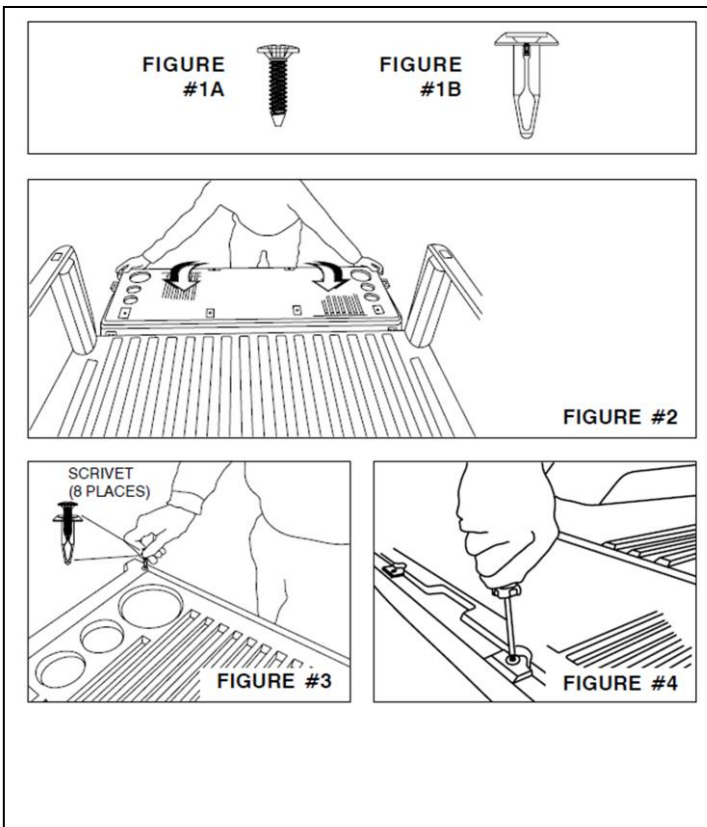

STEP 1 (FIGURE #2)

Center the Tailgate Cover on the Truck Tailgate. Press the Cover Down and Forward into Place. Line up Holes in Tailgate Cover with Holes in Truck Tailgate.

STEP 2 (FIGURE #3)

Place Scrivet Fastener in hole.

PRESS DOWN FIRMLY on the Scrivet Fastener to Seat in Hole.

Repeat Procedure for the 7 Other Scrivet Fasteners.

STEP 3 (FIGURE #4)

Using Phillips Screwdriver, Tighten the 8 Scrivet Screws.

Do Not Over-Tighten.

DO NOT USE POWER TOOLS.

3. Bedliner Installation

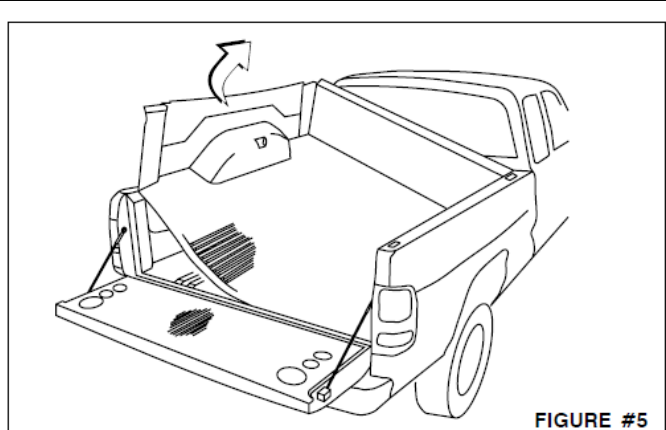

FIGURE #5

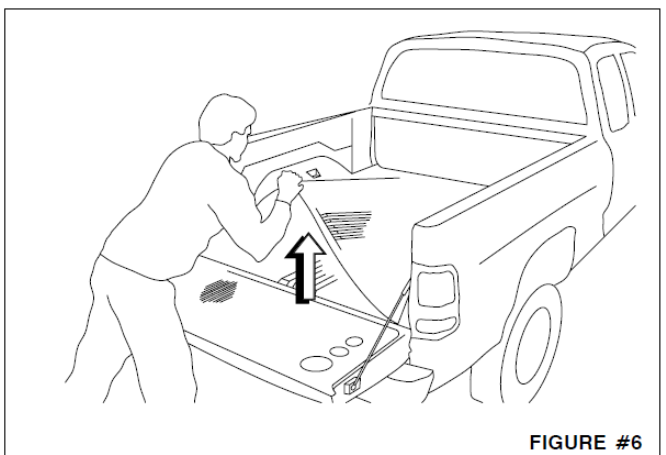

FIGURE #6

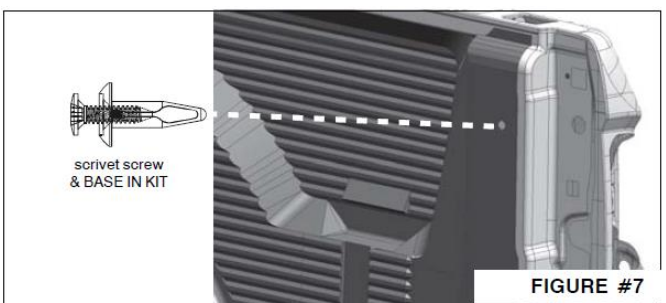

FIGURE #7

CAUTION: It is Recommended that Two (2) People Install the Bedliner to Avoid Damage to the Painted Surface of the Truck.

STEP 1 (FIGURE #5)

Place Bedliner in the Truck Bed, such that, the Front Rail Retainer Fits Over the Front Rail of the Truck Bed. While Standing on the Side of the Truck, Lift One Side of the Bedliner and Rotate the Bedliner, Allowing it to Slip/Lock in Position under the Opposite Side Bed Rail.

STEP 2 (FIGURE #6)

While Standing at the Rear of the Truck, Lift the Bedliner Floor in the Center. This Procedure Allows the Bedliner Sidewall to Rotate Away from the Bed Rail. Have a 2nd Person Slip/Lock the Bedliner Sidewall in Position by Applying a Downward Force.

STEP 3

Check the Overall Fit. It is Important that the Bedliner Fits Securely in Place Under the Bed Rails. If Necessary, Repeat Steps 1-3.

STEP 4

Line up the pre drilled hole in the rear bedliner sidewall and the existing hole in the truck box rear "D" pillar sidewall.

STEP 5 (Figure #7)

Place scrivet fastener in hole. **PRESS DOWN FIRMLY** on the scrivet to seat in hole. Using a Phillips screwdriver, hand tighten the scrivet.

STEP 6

Install Tie-Down Plugs into the Front Floor Bedliner Tie-Down Access Holes. Quad Cab Tie Down Access Holes do not have Tie-Down Plugs.

NOTE: The Bedliner has been Designed to Allow for Expansion/ Contraction in Extreme Ambient Temperatures. Therefore it is Impossible to have a Perfect Fit at All Times.

4. Installing Rear Cargo Supports/Dividers - if desired

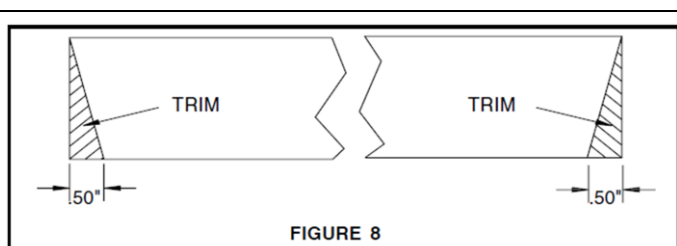

FIGURE 8

Your Bedliner has been Designed with Specific Molded-in Locations that Allow for Customization for Cargo Hauling.

STEP 1

Board Supports Should be Cut to the Following Dimensions:

- a) Upper Level Cargo Supports (Front) - 61.0" Long
- b) Upper Level Cargo Supports (Center) - 50.25" Long
- c) Upper Level Cargo Supports (Rear) - 60.63" Long
- d) Lower Level Cargo Supports (Front) - 57.75" Long
- e) Lower Level Cargo Supports (Rear) - 57.25" Long

Trim Corners as Shown in FIGURE #8



DOUBLURE DE PLATEAU SANS REBORD POUR DODGE DAKOTA



Part No. 22108X, TG53X

Outils Nécessaires:

Tournevis Cruciforme ((Pour attacher les vis dans les chevilles)

1. Préparation pour installation – Vérifiez le contenu du kit :

DOUBLURE DE PLATEAU SANS REBORD POUR DODGE DAKOTA

Description	Qty.	Contenu du kit :
Doublure sans rebord	1	10 chevilles, 2 bouchons pour trou d'attache (caisse courte seulement), Feuillet d'instructions d'installation
Doublure du hayon	1	
Kit d'installation	1	

2. Installation de la doublure du hayon (avec les trous des chevilles dans le hayon du pick-up)

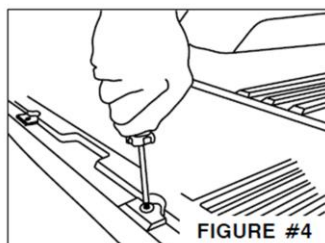
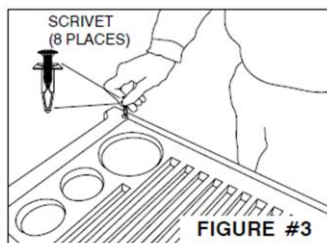
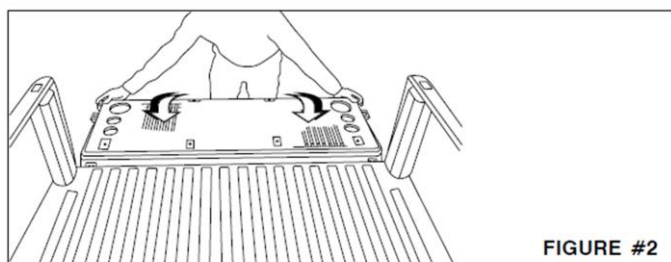
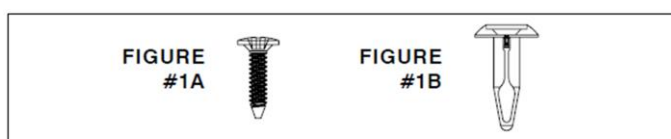

ÉTAPE N°1 (FIGURE N°2)

Centrez la doublure du hayon sur le hayon du pick-up. Installez la doublure en appuyant vers le bas et en avant. Alignez les trous dans la doublure du hayon avec les trous dans le hayon du pick-up.

ÉTAPE N°2 (FIGURE N°3)

Insérez l'attache de la cheville dans le trou.

APPUYEZ FERMEMENT sur l'attache de la cheville afin de l'arrimer dans le trou.

Placez les autres attaches de cheville de la même façon.

ÉTAPE N°3 (FIGURE N°4)

Avec un tournevis cruciforme, serrez les 8 vis des chevilles. Ne serrez pas trop fort.

N'UTILISEZ PAS D'OUTILS ÉLECTRIQUES.

3. Installation de la doublure du plateau

PRUDENCE: Il est conseillé à deux (2) personnes d'installer la doublure du plateau afin d'éviter des dégâts à la surface peinte du pick-up.

ÉTAPE N°1 (FIGURE N°5)

Installez la doublure sur le plateau du pick-up de sorte que le rebord avant recouvre la paroi avant du plateau du pick-up. Debout, à côté du pick-up, levez un côté de la doublure du plateau et tournez-la de façon à ce qu'elle glisse et soit bloquée en dessous de la paroi latérale opposée.

ÉTAPE N°2 (FIGURE N°6)

Debout, à l'arrière du pick-up, relevez la doublure en son centre. Ainsi, vous permettez la paroi latérale de la doublure du plateau de se dégager de la paroi latérale du pick-up. Pendant ce temps, une 2^{ème} personne glisse et bloque la paroi latérale de la doublure du plateau en place en appuyant vers le bas.

ÉTAPE N°3

Vérifiez que l'installation est bien ajustée. Il est important que la doublure du plateau soit bien placée en dessous des parois latérales du pick-up. Répétez les étapes 1 à 3 si nécessaire.

ÉTAPE N°4

Aligner le trou de la doublure en arrière et le trou dans la paroi de la caisse en arrière, pilier "D".

ÉTAPE N°5 (Figure NO 7)

Placer une vis autotaraudeuse dans le trou. Poussez fermement. Avec un tournevis, serrer la vis autotaraudeuse.

ÉTAPE N°6

Installez les bouchons dans les trous avant du plancher de la doublure du plateau. Pour le Quad Cab, les trous en arrière n'ont pas de bouchons.

REMARQUE: La doublure du plateau a été conçue de façon à permettre l'expansion ou la contraction à des températures ambiantes extrêmes. Aussi, il est impossible d'avoir toujours un ajustement parfait.

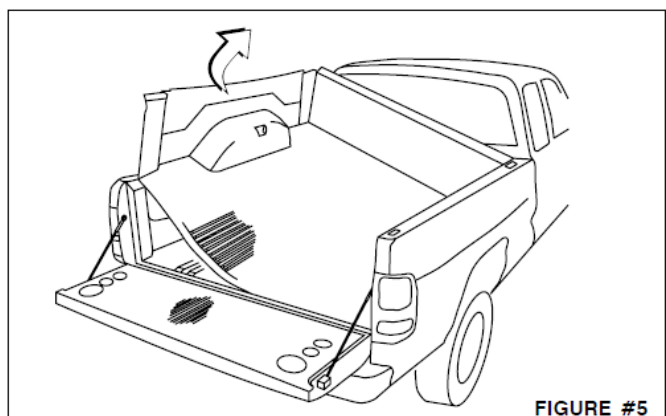

FIGURE #5

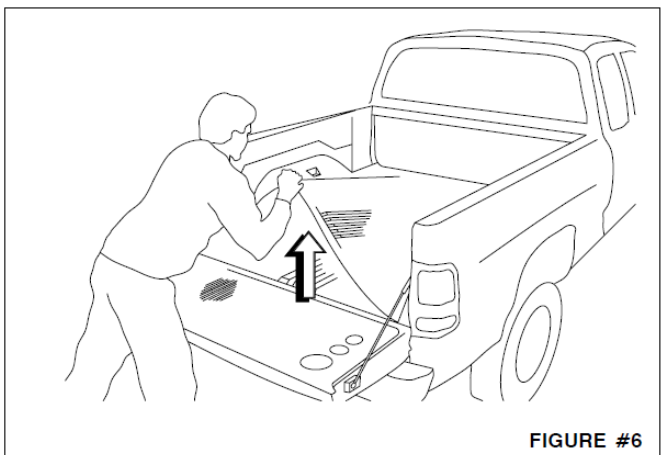
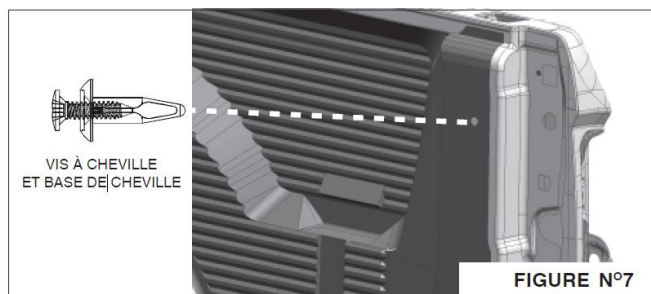

FIGURE #6



VIS À CHEVILLE
ET BASE DE CHEVILLE

FIGURE N°7

4. Installation des supports arrière de cargaison / diviseurs – si désiré

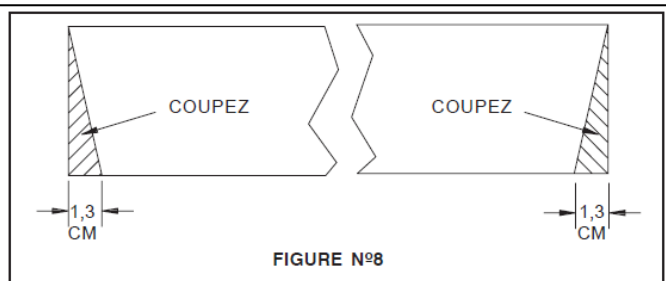

FIGURE N°8

Votre doublure MOPAR de plateau est munie d'emplacements moulés spécialement conçus pour personnaliser le transport des cargaisons.

ÉTAPE 1

Coupez les supports en bois aux dimensions suivantes :

- Supports supérieurs de cargaison
(Avant) – 154,9 cm en longueur
 - Supports supérieurs de cargaison
(Centre) – 128,6 cm en longueur
 - Supports supérieurs de cargaison
(Arrière) – 154,0 cm en longueur
 - Supports inférieurs de cargaison
(Avant) – 146,7 cm en longueur
 - Supports inférieurs de cargaison
(Arrière) – 145,4 cm en longueur
- Coupez les coins selon la FIGURE N°8



DEL FORRO BAJO LA BARANDA PARA DODGE DAKOTA



Part No. 22108X, TG53X

HERRAMIENTAS NECESARIAS:

Destornillador Phillips (Para asegurar los tornillos en los tarugos)

1. Preparación para instalar - Verifique el contenido del juego:

FORRO BAJO LA BARANDA PARA DODGE DAKOTA

Descripción	Cantidad	Contenido del juego:
Forro bajo la baranda	1	10 tarugos, 2 Tapones para los
Cubierta de la compuerta trasera	1	hoyos de amarre (solo por chico caja),
Juego de instalación	1	

2. Instalación de la cubierta de la compuerta trasera (con hoyos para tarugos en la compuerta trasera)

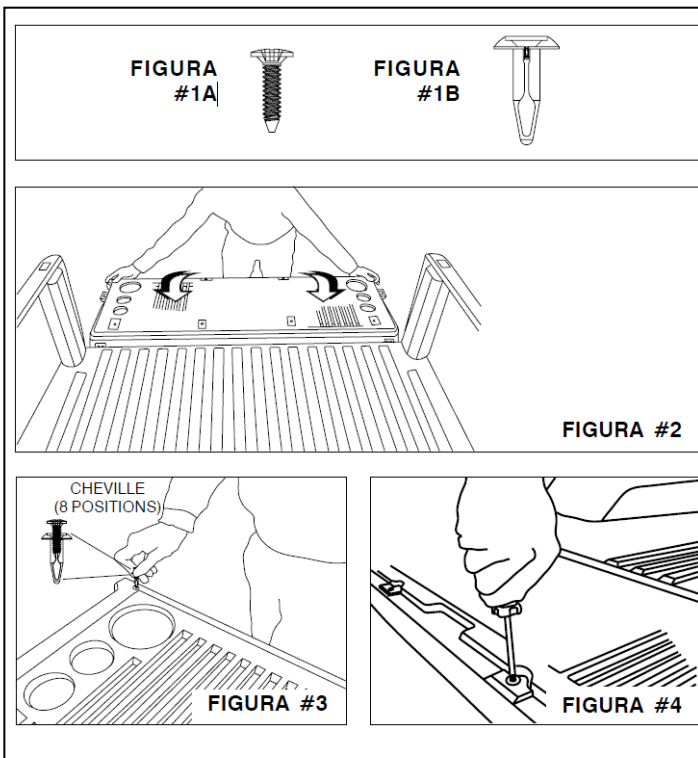

PASO 1 (FIGURA #1)

Centre la cubierta de la compuerta trasera en la compuerta trasera de la camioneta. Presione la cubierta hacia abajo y hacia adelante en su lugar. Alinee los hoyos en la cubierta de la compuerta trasera con los hoyos en la compuerta trasera de la camioneta.

PASO 2 (FIGURA #2)

Ponga el sujetador de tarugo en el hoyo.
PRESIONE FIRMEMENTE HACIA ABAJO el sujetador de tarugo para que quede en el hoyo.

Repita el procedimiento en los otros 7 sujetadores de tarugo.

PASO 3 (FIGURA #3)

Utilizando un destornillador Phillips, ajuste los 8 tornillos de tarugo.

No los apriete demasiado.
NO UTILICE HERRAMIENTAS ELÉCTRICAS.

3. Instalación del forro en la caja

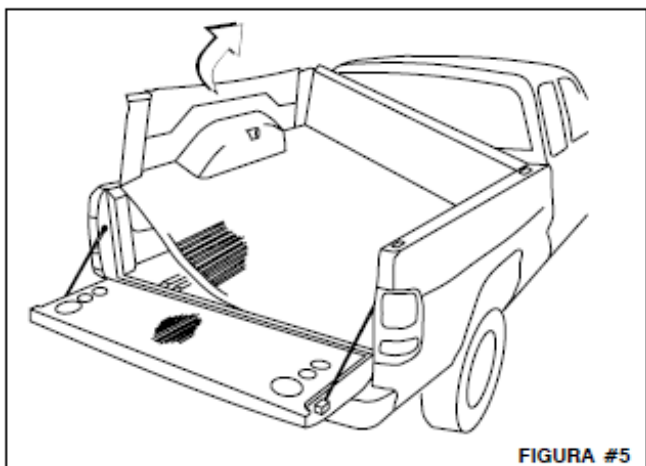

PRECAUCIÓN: Se recomienda que dos (2) personas instalen el forro para evitar daños a la pintura de la carrocería de la camioneta.

PASO 1 (FIGURA #5)

Coloque el forro en la caja de la camioneta, de modo que el retenedor de la baranda frontal quepa sobre la baranda frontal de la caja de la camioneta. Parándose al lado de la camioneta, levante un lado del forro y rótelo, permitiendo que se deslice o encaje en su posición bajo el lado opuesto de la baranda lateral de la caja.

PASO 2 (FIGURA #6)

Parándose en la parte trasera de la camioneta, levante el piso del forro en el centro. Este procedimiento le permite a la pared lateral del forro rotar hacia el lado opuesto de la baranda de la caja. Pida a una segunda persona que deslice o encaje la pared lateral del forro en su posición aplicando fuerza hacia abajo.



PASO 3

Revise el ajuste general. Es importante que el forro quede ajustado seguramente en su lugar bajo las barandas de la caja. Si es necesario, repita los pasos 1-3.

PASO 4

Alinearse los hoyos perforado atrás de el lado de el protector con el hoyo existente atrás "D" columna de el lado de la caja.

PASO 5 (Figura #7)

Coloque el remache tornillo en el hoyo. **OPRIMIR FIRMENTE** el remache tornillo para asegurar el tornillo en el hoyo. Usar destornillador Phillips y apretar a mano.

PASO 6

Instale los tapones de amarre en los hoyos de acceso de amarre al frente del piso del forro. Para la doble cabina, no tiene tapones de amarre in los hoyos de acceso traseros.

NOTA: El forro está diseñado para permitir la expansión o contracción en temperaturas ambientales extremas. Por lo tanto, es imposible que se fije perfectamente siempre.

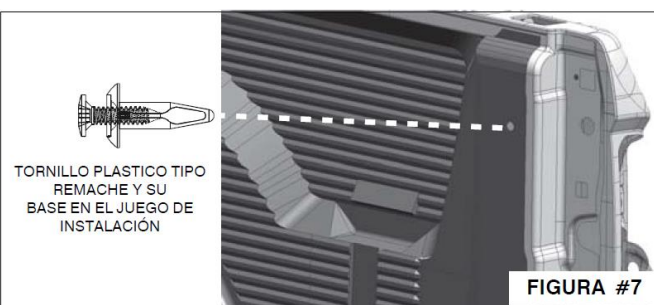

4. Instalación de los soportes/divisores de carga traseros – si se desea

PASO 1

Los soportes de madera se deben cortar en las siguientes dimensiones:

- Soportes de carga del nivel superior (Frente) – 152.5 cm (61.0") de largo
- Soportes de carga del nivel superior (Centro) – 125.625 cm (50.25") de largo
- Soportes de carga del nivel superior (Atrás) – 151.575 cm (60.63") de largo
- Soportes de carga del nivel inferior (Frente) – 144.375 cm (57.75") de largo
- e) Soportes de carga del nivel inferior (Atrás) – 143.125 cm (57.25") de largo

Recorte las esquinas como se muestra en la FIGURA #8

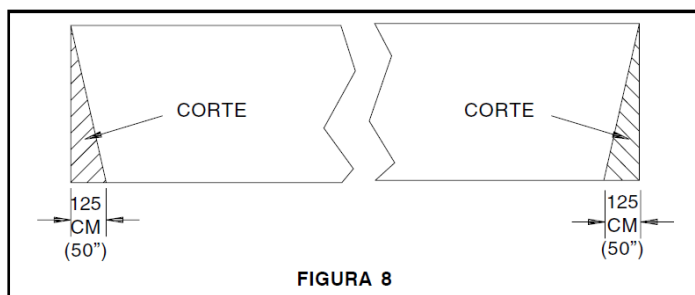

El forro está diseñado con localizaciones específicas moldeadas para permitir ajustar el arrastre de carga.

PRODUCT CARE

- Sweep any dirt and debris out of the bed of the truck. Pick up any items that may scratch the liner, such as rocks or large sticks.
- Inspect Bed liner on frequent basis to identify any damages.
- Clean the product with mild soap / cleaner to remove stains.
- While washing Rinse bed and tailgate thoroughly until no soap runs off the truck.

FAQ's

- 1. Will the bed feel hotter than the rest of the truck?**
No, protective coating shall help to keep it cooler than truck.
- 2. Protective coating is used as an undercoating?**
Yes, it can be used.
- 3. Is protective coating environmentally friendly?**
Yes, there is no possible health hazard and it is environment friendly
- 4. Can I take it out Protective Coating?**
No, Protective coating is a permanent coating and can't be removed.
- 5. Does the lining require special maintenance?**
No, it can be cleaned up with mild soap.
- 6. Missing / Excess Hardware.**
Recheck hardware count as per the part list.
- 7. Product not installing properly.**
Ensure make model year, cab length and bed size of your vehicle is listed in the application. All installation steps are followed correctly.

Check out these other TrailFX Products!!

www.TrailFX.com



Keystone Automotive Operations Inc. (KAO) warrants this product to be free of defects in material and workmanship at the time of purchase by the original retail consumer. KAO disclaims any other warranties, express or implied, including the warranty of fitness for a particular purpose or an intended use. If the product is found to be defective, KAO may replace or repair the product at our option, when the product is returned prepaid, with proof of purchase. Alteration to, improper installation, or misuse of this product voids the warranty. KAO's liability is limited to repair or replacement of products found to be defective, and specifically excludes liability for any incidental or consequential loss or damage.