



3" Side Bar

Part No. A0054S /B



Fits: **2019-Current Dodge Ram 1500 Quad Cab (Excl. 19-20 Ram 1500 Classic)**



REMOVE CONTENTS FROM BOX. VERIFY ALL PARTS ARE PRESENT.



READ INSTRUCTIONS CAREFULLY BEFORE STARTING INSTALLATION.

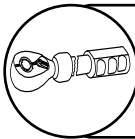

DO NOT OVER TORQUE. STANDARD OPERATING LOAD FOR TIGHTENING BODY MOUNT NUTS & BOLTS VARIES FROM 18 TO 20 FOOT POUND FOR M8 AND 60 TO 70 FOOT POUND FOR M12.



60-180 min



Cutting Not Required



Drilling Not Required



support@trailfx.com



1 866 638 4870



POLISHED STAINLESS STEEL - LIMITED LIFETIME
POWDER COATED BLACK - 3 YEARS

PARTS LIST:

Qty	Part Description	Qty	Part Description
2	3" 90 deg. Bent End Sidebars	1	Driver/left side Rear Support Bracket
1	Driver/left side Front Mounting Bracket	1	Passenger/right side Rear Support Bracket
1	Passenger/right side Front Mounting Bracket	4	1/2" x 2" Hex Bolts
1	Driver/left side Rear Mounting Bracket	4	1/2" x 1-1/2" x 1/8" Flat Washers
1	Passenger/right side Rear Mounting Bracket	4	1/2" Lock Washers
1	Driver/left side Front Support Bracket	12	8-1.25mm Nylon Lock Nuts
1	Passenger/right side Front Support Bracket	12	8mm x 24mm x 2mm Flat Washers

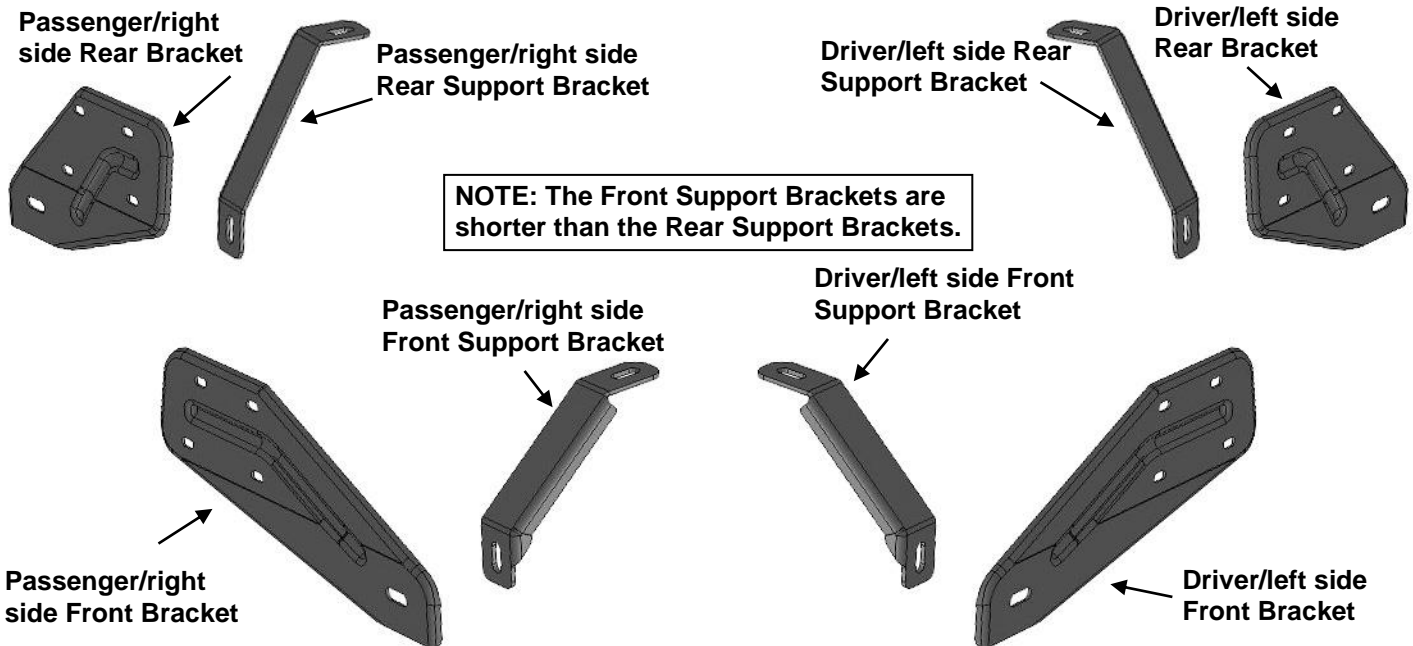

PROCEDURE:

REMOVE CONTENTS FROM BOX. VERIFY ALL PARTS ARE PRESENT. READ INSTRUCTIONS CAREFULLY BEFORE STARTING INSTALLATION. ASSISTANCE IS RECOMMENDED.

1. Start the installation under the driver/left side of the vehicle. Locate the front (3) factory studs along the inner side of the body panel, **(Figure 1)**. **IMPORTANT:** Use a wire brush or thread die to remove paint buildup on the threaded studs before continuing with installation.

2. Select the driver/left Front Mounting Bracket, **(Figure 2)**. Place the Bracket over the studs with the flat side against the body panel. Attach the Bracket to the (3) factory studs with (3) 8mm Flat Washers and (3) 8mm Nylon Lock Nuts, **(Figures 2 & 3)**. Leave Bracket loose at this time.
3. Locate the front body mount next to the installed Bracket, **(Figure 4)**. Remove the body bolt and washer, **(Figure 5)**. **NOTE:** Clean threads on body bolt to remove paint buildup before reinstalling.
4. Select the driver/left Front Support Bracket, **(Figure 6)**. Reuse the factory body bolt and washer to attach the upper slot in the Support Bracket to the body mount. **(Figures 7 & 8)**.
5. Move to the rear mounting location, **(Figure 9)**. Repeat **Steps 1—4** to attach the driver/left Rear Mounting Bracket and Support Bracket, **(Figure 10)**.
6. Carefully unwrap and select (1) Sidebar. With assistance, line up the front end of the tube with the front Bracket, **(Figure 11)**. Attach the front end of the Sidebar to the Front Brackets with the included 1/2" Hex Bolt, 1/2" Lock Washer and 1/2" Flat Washer, **(Figures 11 & 12)**. Do not tighten hardware.
7. Move to the rear of the Sidebar. Repeat **Step 6** to attach the Sidebar to the rear Brackets, **(Figure 13)**.
8. Level and adjust the Sidebar as necessary and fully tighten all hardware.
9. Repeat **Steps 1—8** for passenger/right Sidebar.
10. Do periodic inspections to the installation to make sure that all hardware is secure and tight.

To protect your investment, wax this product after installing. Regular waxing is recommended to add a protective layer over the finish. Do not use any type of polish or wax that may contain abrasives that could damage the finish. Mild soap may be used also to clean the Sidebar.

Driver/left Side Installation Pictured

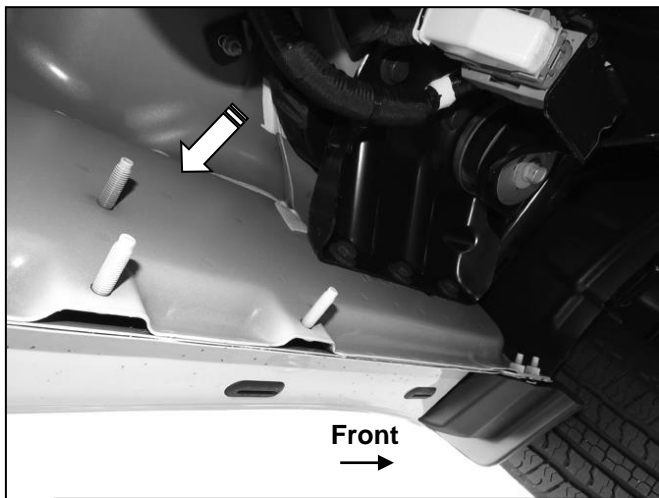

(Fig 1) Driver/left front mounting location

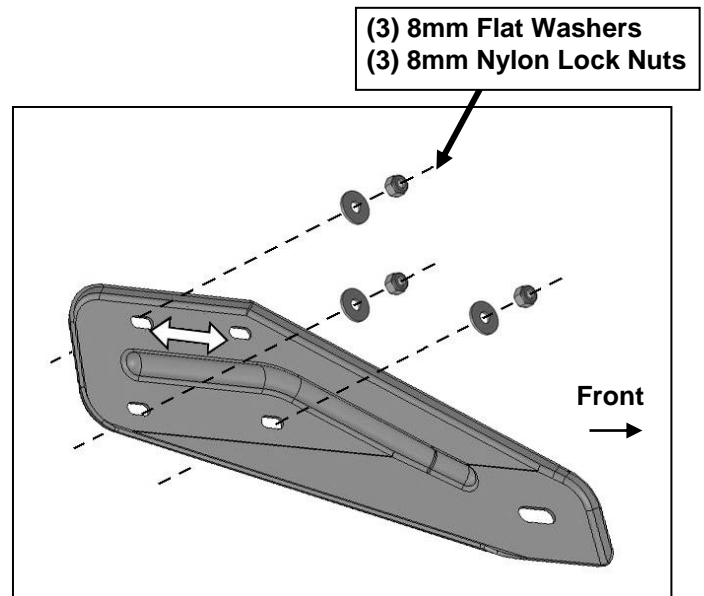

(Fig 2) Attach flat side of Driver/left Front Mounting Bracket to side of inner body panel

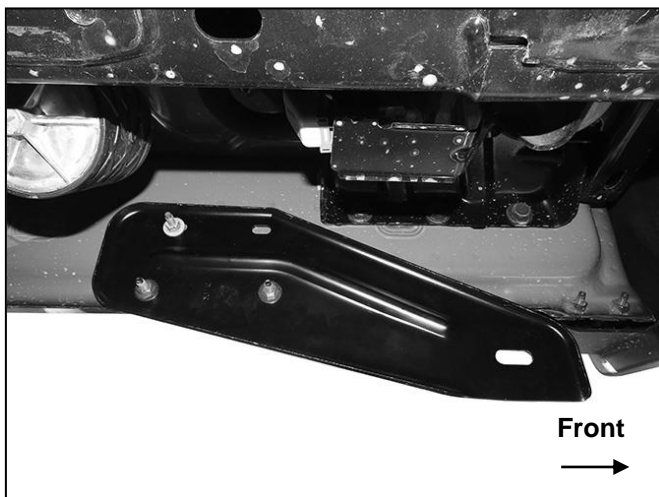

(Fig 3) Driver/left Front Bracket installed

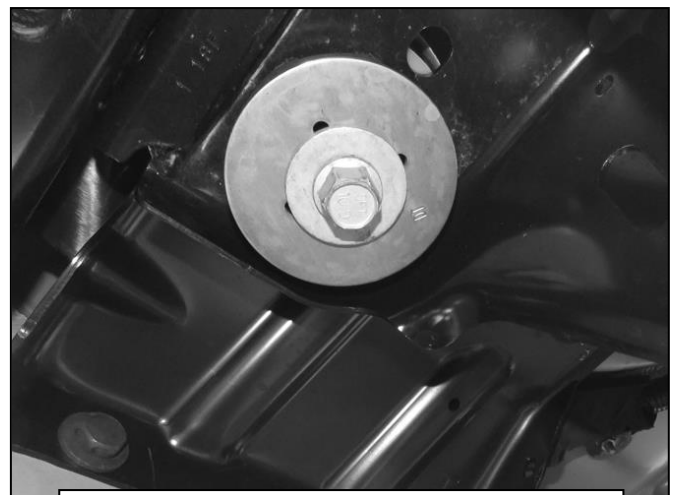

(Fig 4) Locate driver/left front body mount (passenger side pictured for example)

Driver/left Side Installation Pictured



(Fig 5) Remove factory body bolt

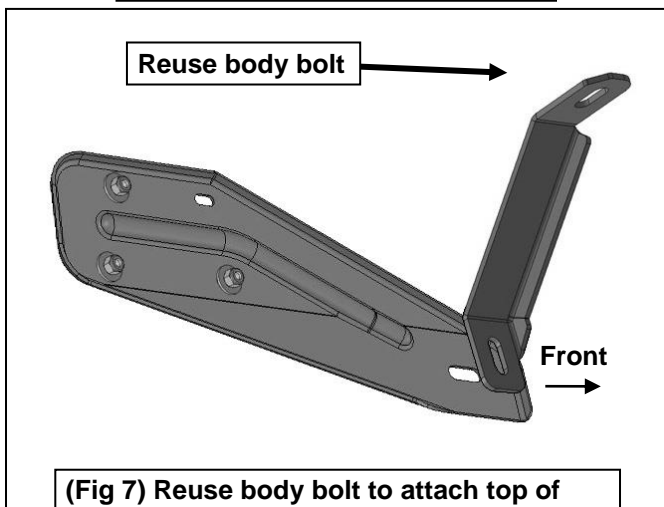

(Fig 7) Reuse body bolt to attach top of Support Bracket to body mount (Driver/left Front Support Bracket illustrated)



(Fig 6) Driver/left Front and Rear Support Brackets. NOTE: Front Support Bracket (left) is shorter than the rear (right).



(Fig 8) Driver/left Front Support Bracket attached to body mount

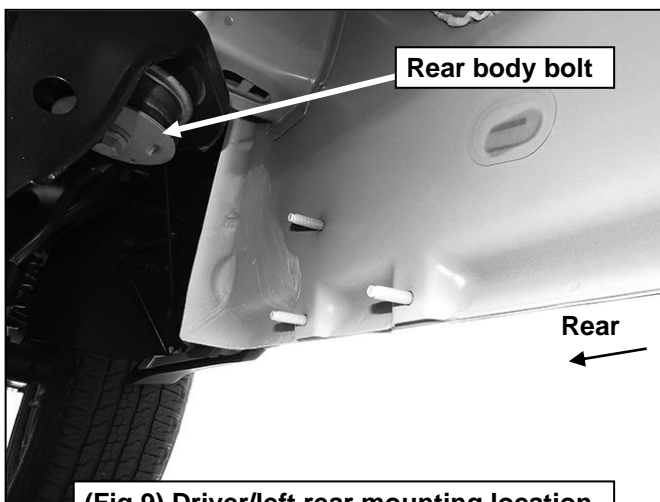

(Fig 9) Driver/left rear mounting location

Driver/left Side Installation Pictured

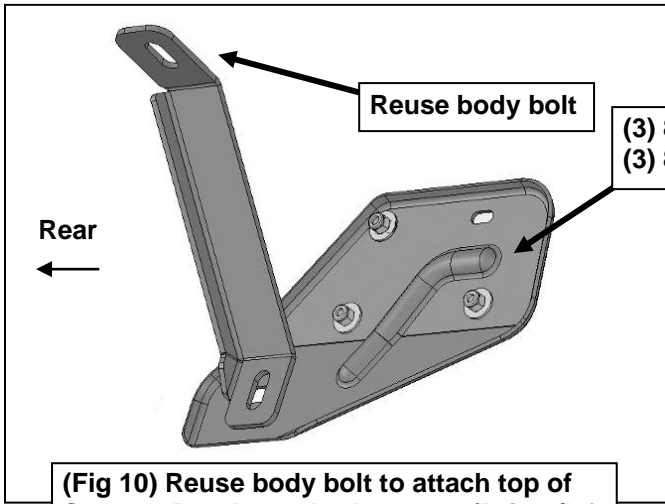

NOTE: The Front Support Bracket is shorter than the Rear Support Bracket.

(3) 8mm Flat Washers
(3) 8mm Nylon Lock Nuts

1/2" x 2" Hex Bolt
1/2" Lock Washer
1/2" Flat Washer

(Fig 10) Reuse body bolt to attach top of Support Bracket to body mount (Driver/left Rear Support Bracket illustrated)

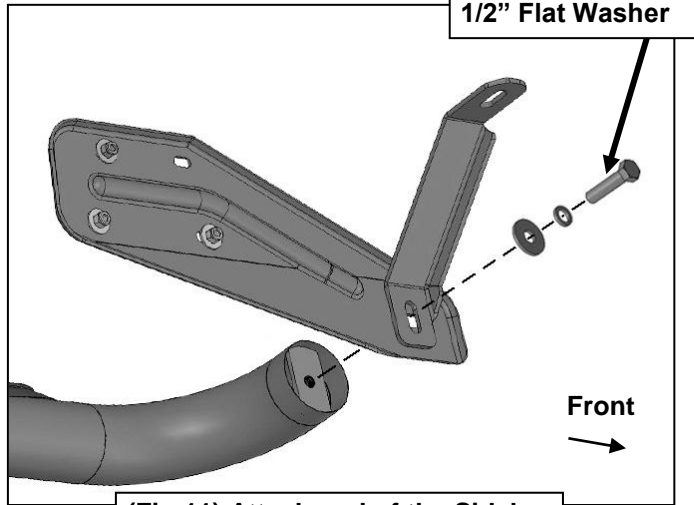

(Fig 11) Attach end of the Sidebar to the driver/left front Bracket

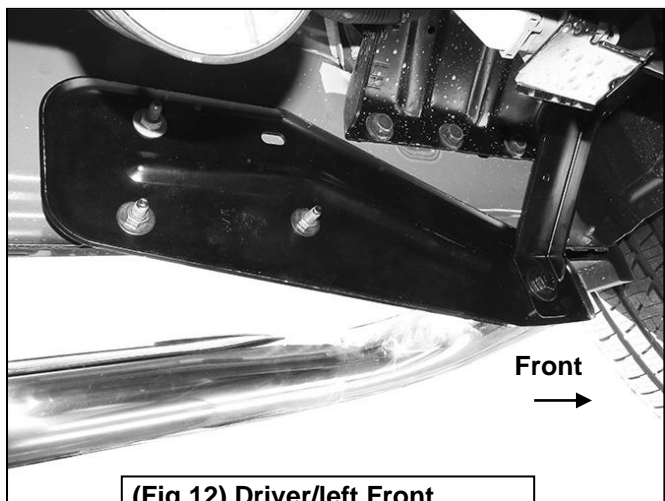

(Fig 12) Driver/left Front Brackets and Sidebar installed

1/2" x 2" Hex Bolt
1/2" Lock Washer
1/2" Flat Washer

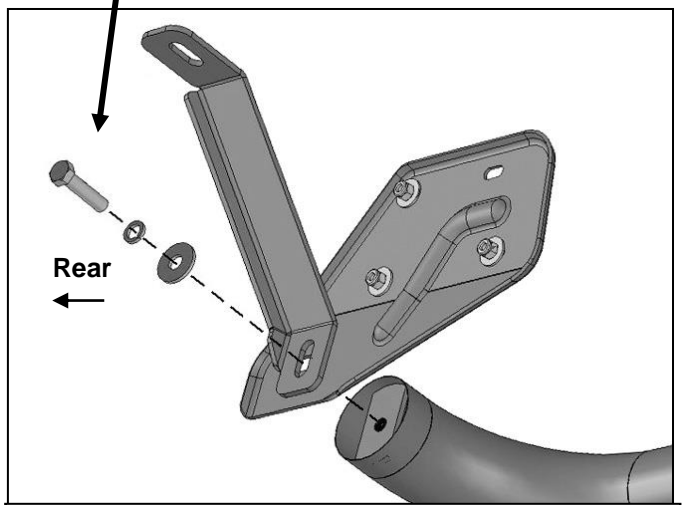

(Fig 13) Attach Sidebar to Driver/left Rear Brackets



No.	Parts Identification
1	Passenger / Right 'Rear' Bracket marked "PR"
2	Driver / Left 'Rear' Bracket marked "DR"
3	Passenger / Right 'Center' Bracket marked "PC"
4	Driver / Left 'Center' Bracket marked "DC"
5	Passenger / Right 'Front' Bracket marked "PF"
6	Driver / Left 'Front' Bracket marked "DF"

Note:

- This guide is to identify the parts and not a reference for part count.
- For part count, refer Parts List.
- Product / Bracket image is representative and actual design may vary.

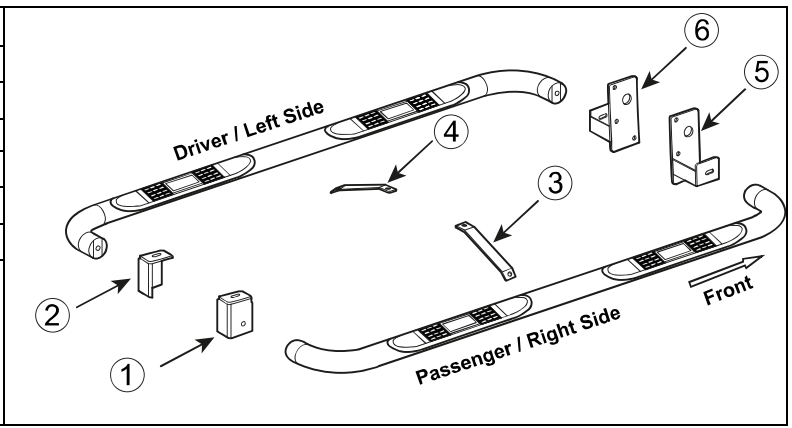

PRODUCT CARE

- Periodically check the product to ensure all fasteners are tight and components are intact.
- Regular waxing is recommended to protect the finish of the product.
- **Use ONLY Non-Abrasive automotive wax.** Use of any soap, polish or wax that contains an abrasive is detrimental and can scratch the finish leading to corrosion.
- Aluminum polish may be used to polish small scratches and scuffs for **Stainless Steel finish.**
- Mild soap may be used to clean the product for both **Stainless Steel and Black finish.**

FAQ's

- 1. Hardware's are not of correct size.**
In GMC / Chevrolet truck model 2006 & up, customer needs to reuse the factory body bolts to install the bracket. If your vehicle is not GMC / Chevrolet 2006 & up, ensure that holes are not partially covered with any plastic grommet or rust? If it is, remove the plastic grommet & rust from the thread holes & re-try the installation.
- 2. Mounting Bracket are not getting Installed properly.**
In some cases Illustration images shown in Installation manual may not be the exactly same as per actual vehicle images ,also if Driver / Passenger side mounting brackets are very identical in the design, suggest referring Parts Identification guide to avoid fitment issue.
- 3. Products are thumping / rattling after installation.**
Ensure that all required mounting brackets / hardware's are installed & tighten correctly. Suggest using white lithium / regular grease between the metal to metal contact surfaces.
- 4. Side Bar is not aligning with vehicle / Step Pads are not aligning with vehicle doors.**
Side bar may be interchanged or mounting brackets are not installed at the correct position in the vehicle. Refer Parts identification guide.
- 5. Missing / Excess Hardware.**
Recheck hardware count as per the part list.
- 6. Product not installing properly.**
Ensure make model year, cab length and bed size of your vehicle is listed in the application. All installation steps are followed correctly.

Check out these other TrailFX Products!!

www.TrailFX.com



Keystone Automotive Operations Inc. (KAO) warrants this product to be free of defects in material and workmanship at the time of purchase by the original retail consumer. KAO disclaims any other warranties, express or implied, including the warranty of fitness for a particular purpose or an intended use. If the product is found to be defective, KAO may replace or repair the product at our option, when the product is returned prepaid, with proof of purchase. Alteration to, improper installation, or misuse of this product voids the warranty. KAO's liability is limited to repair or replacement of products found to be defective, and specifically excludes liability for any incidental or consequential loss or damage.