

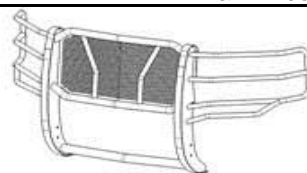

Extreme Grille Guard

Part No. 2720229103



Fits: 2010 - Current

Dodge Ram 2500/3500



ASSISTANCE IS RECOMMENDED.



REMOVE CONTENTS FROM BOX. VERIFY ALL PARTS ARE PRESENT.



READ INSTRUCTIONS CAREFULLY BEFORE STARTING INSTALLATION.

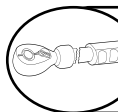

DO NOT OVER TORQUE. STANDARD OPERATING LOAD FOR TIGHTEN BODY MOUNT NUTS & BOLTS VARIES FROM 45 TO 65 FOOT POUND.



60-180 min



Cutting Required



Drilling Not Required



support@trailfx.com



1 866 638 4870



WARRANTY POLISHED STAINLESS STEEL – LIMITED LIFETIME
POWDER COATED BLACK – 3 YEARS

PARTS LIST:

Qty	Part Description	Qty	Part Description
1	Extreme Grille Guard	6	12mm Lock Washers
1	Driver/Left Frame Mounting Bracket	6	12mm Hex Nuts
1	Passenger/Right Frame Mounting Bracket	8	10-1.5mm x 45mm Gr. 10.9 Hex Bolts
1	Driver/Left Lower Mounting Bracket	16	10mm x 27mm OD x 3mm Flat Washers
1	Passenger/Right Lower Mounting Bracket	8	10mm Lock Washers
6	12-1.75mm x 40mm Gr. 10.9 Hex Bolts	8	10mm Hex Nuts
12	12mm x 32mm OD x 3mm Flat Washers		



Passenger/Right side Frame Bracket

Passenger/Right Lower Mounting Bracket



Driver/Left side Frame Bracket

Driver/Left Lower Mounting Bracket

INSTALLATION PROCEDURE:**ASSISTANCE IS RECOMMENDED. CUTTING IS REQUIRED.**

1. Starting under the front bumper, carefully remove the plastic splash guard from the bottom of the bumper. Depending on the model of truck, the splash guard may be attached to the bumper with hex bolts and several two-piece plastic push-in clips. First, remove all hex bolts, then locate the clips behind and across the front of the bumper, **(Figure 1A)**. Pry up on the center pin of the clip with a flat blade screwdriver to release the pin then remove the entire clip, **(Figure 1B)**. **NOTE:** Pay close attention to the type and location of all factory hardware for reinstallation. Move the splash guard to a clean stable work area.
2. Remove the driver side tow hook, **(Figure 2)**. **NOTE:** The factory hex bolts and nuts securing the inner (2) tow hook bolts may be difficult to remove. Assistance is recommended. Use a socket with a long extension to reach the hex nuts on the inner tow hook bolts. Once the tow hook has been removed, **(Figure 3)**, select the driver side Frame Bracket and place it between the tow hook and the frame. Secure the tow hook and Frame Bracket to the vehicle with (4) 10mm x 45mm Hex Bolts, (8) 10mm Flat Washers, (4) 10mm Lock Washers and (4) 10mm Hex Nuts, **(Figure 4)**. Snug but do not tighten hardware at this time.
3. Select the driver side Lower Mounting Bracket. Remove the (2) factory hex nuts securing the lower part of the bumper to the bumper bracket. Line up the mounting hole and slot in the Bracket with the (2) bumper bolts and secure with the factory hex nuts, **(Figure 5)**. Snug but do not tighten hardware at this time. Repeat Step 3 – 4 for passenger side Mounting Bracket installation.
4. Hold the plastic splash guard up in the approximate position. Mark the areas indicated onto the driver and passenger side of the splashguard, **(Figure 6)**. Cut out (2) openings for the lower Mounting Brackets, **(Figure 7)**. Reinstall the splash guard using the factory hardware.
5. With assistance, position the Grille Guard up to the Frame Mounting Brackets. Use the included (4) 12mm x 40mm Hex Bolts, (8) 12mm Flat Washer, (4) 12mm Lock Washers and (4) 12mm Hex Nuts to attach the Grille Guard to the Frame Mounting Brackets, **(Figure 8)**. Insert the lower tabs on the Grille Guard through the openings cut into the splash guard in **Step 5**. Trim plastic as necessary to properly clear brackets. Snug but do not tighten hardware at this time.
6. Line up the holes and attach the Grille Guard to the Lower Mounting Brackets using the included (2) 12mm x 40mm Hex Bolts, (4) 12mm Flat Washers, (2) 12mm Lock Washers and (2) 12mm Hex Nuts, **(Figure 9)**. Snug but do not tighten at this time.
7. With assistance, align and adjust the Grille Guard and tighten all hardware. **IMPORTANT:** Do not allow the Frame Mounting Brackets to contact the bumper. Align the Frame Mounting Brackets so that they are centered, side-to-side and that there is an even gap between the Brackets and the steel bumper.
8. Do periodic inspections to the installation to make sure that all hardware is secure and tight.

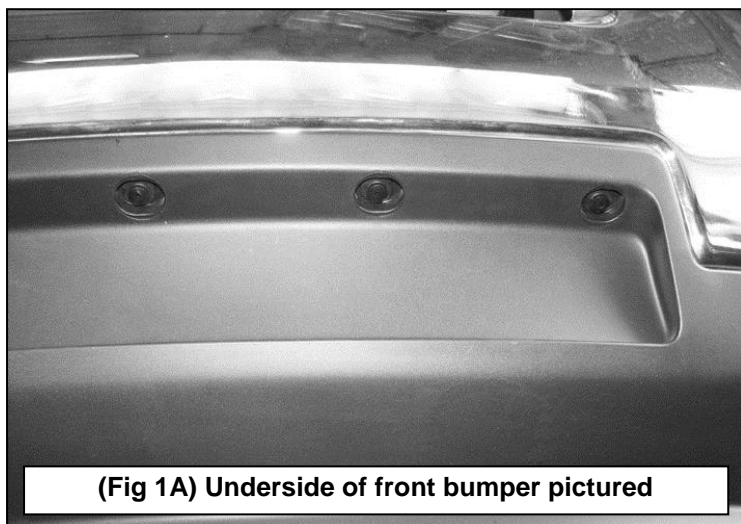
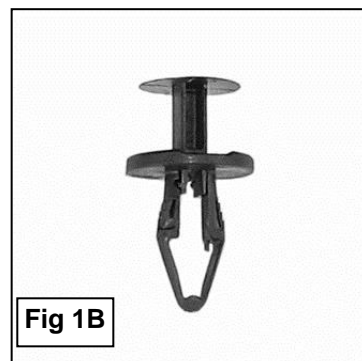
Driver Side Installation Pictured**(Fig 1A) Underside of front bumper pictured****Fig 1B****Pictured for example only,
actual clip may differ**

Driver Side Installation Pictured



- (4) 10mm x 45mm Hex Bolts
- (8) 10mm Flat Washers
- (4) 10mm Lock Washers
- (4) 10mm Hex Nuts

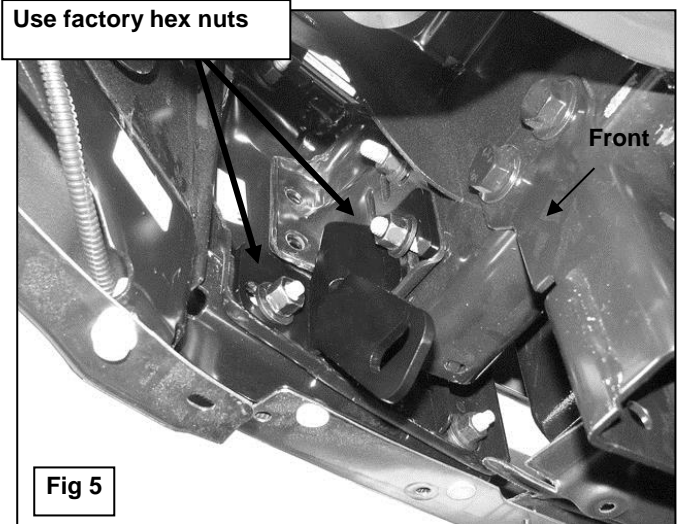
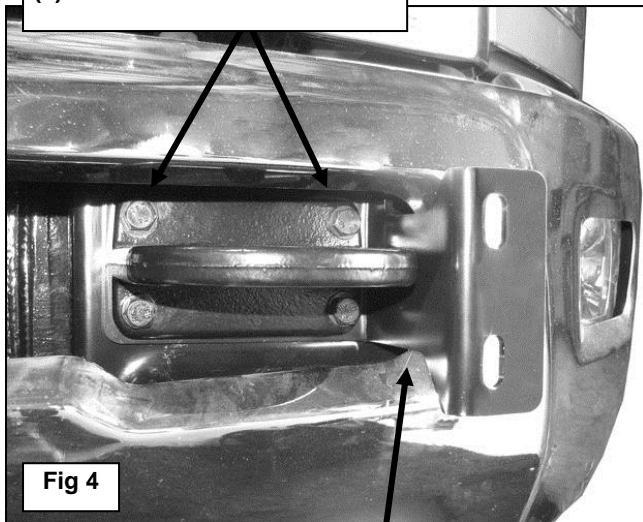

IMPORANT: To prevent damage to the bumper and/or Frame Mounting Brackets, do not allow the Brackets to come in contact, top or bottom, with the steel bumper

Driver Side Installation Pictured

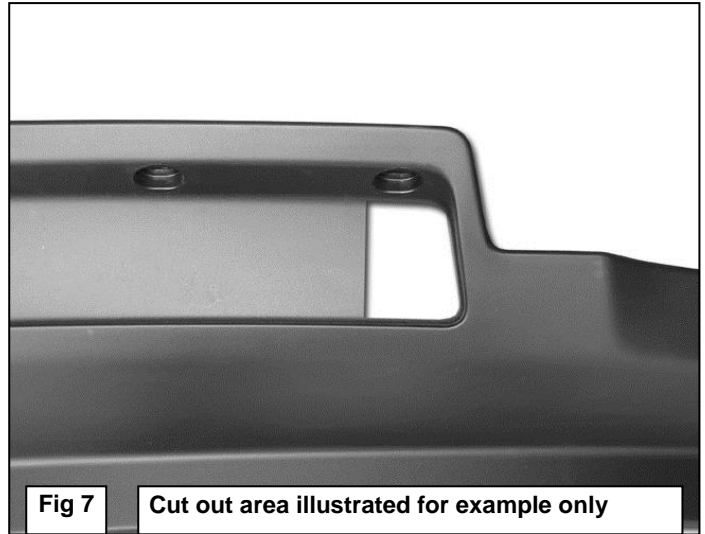
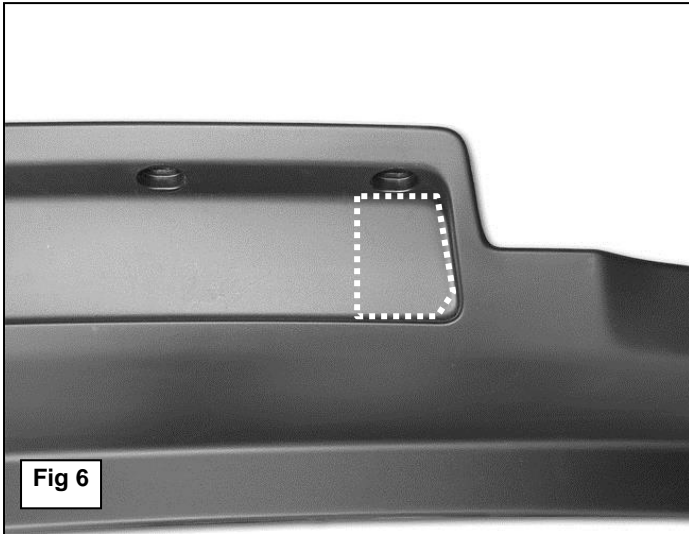

12mm x 40mm Hex Bolt
(2) 12mm Flat Washers
12mm Lock Washer
12mm Hex Nut

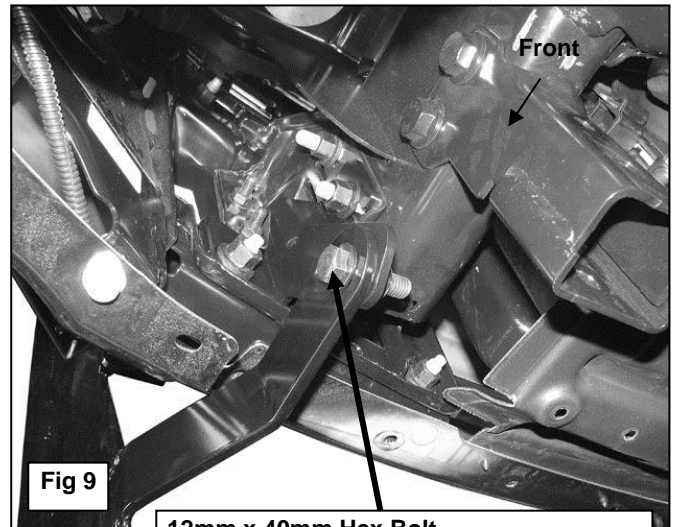
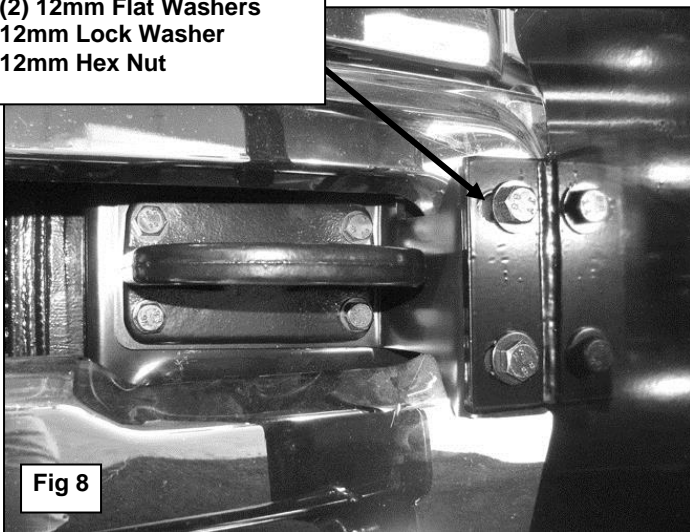

12mm x 40mm Hex Bolt
(2) 12mm Flat Washers
12mm Lock Washer
12mm Hex Nut
(Pictured from below without splash guard for illustration purposes only)

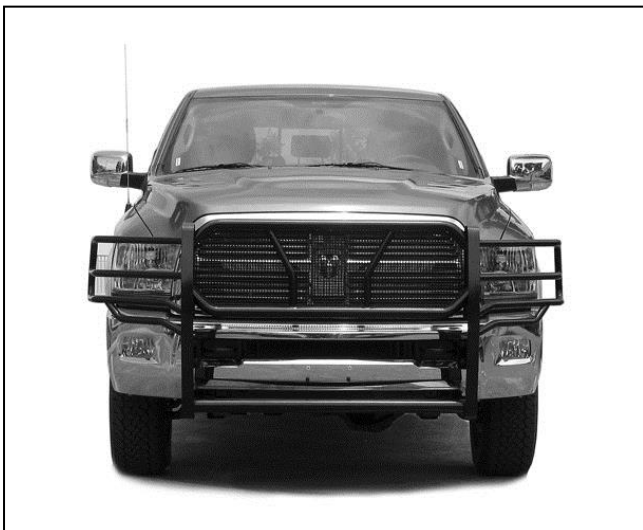

PRODUCT CARE

- Periodically check the product to ensure all fasteners are tight and components are intact.
- Regular waxing is recommended to protect the finish of the product.
- **Use ONLY Non-Abrasive automotive wax.** Use of any soap, polish or wax that contains an abrasive is detrimental and can scratch the finish leading to corrosion.
- Aluminum polish may be used to polish small scratches and scuffs for **Stainless Steel finish.**
- Mild soap may be used to clean the product for both **Stainless Steel and Black finish.**

FAQ's**1. Hardware's are not of correct size.**

In GMC / Chevrolet truck model 2006 & up, customer needs to reuse the factory body bolts to install the bracket. If your vehicle is not GMC / Chevrolet 2006 & up, ensure that holes are not partially covered with any plastic grommet or rust? If it is, remove the plastic grommet & rust from the thread holes & re-try the installation.

2. Mounting Bracket are not getting Installed properly.

In some cases Illustration images shown in Installation manual may not be the exactly same as per actual vehicle images ,also if Driver / Passenger side mounting brackets are very identical in the design, suggest referring Parts Identification guide to avoid fitment issue.

3. Products are thumping / rattling after installation.

Ensure that all required mounting brackets / hardware's are installed & tighten correctly. Suggest using white lithium / regular grease between the metal to metal contact surfaces.

4. Side Bar is not aligning with vehicle / Step Pads are not aligning with vehicle doors.

Side bar may be interchanged or mounting brackets are not installed at the correct position in the vehicle. Refer Parts identification guide.

5. Missing / Excess Hardware.

Recheck hardware count as per the part list.

6. Product not installing properly.

Ensure make model year, cab length and bed size of your vehicle is listed in the application. All installation steps are followed correctly.

Check out these other TrailFX Products!!

www.TrailFX.com



SIDE BAR



HEADACHE RACKS



RUNNING BOARDS



ROCKER GUARDS

Keystone Automotive Operations Inc. (KAO) warrants this product to be free of defects in material and workmanship at the time of purchase by the original retail consumer. KAO disclaims any other warranties, express or implied, including the warranty of fitness for a particular purpose or an intended use. If the product is found to be defective, KAO may replace or repair the product at our option, when the product is returned prepaid, with proof of purchase. Alteration to, improper installation, or misuse of this product voids the warranty. KAO's liability is limited to repair or replacement of products found to be defective, and specifically excludes liability for any incidental or consequential loss or damage.