

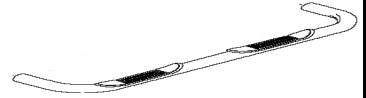

# 3" Side Bar

## Part No. A0018S/B



**Fits: 2014**

**Kia Sorento**



60-180 min

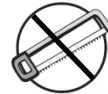

CUTTING NOT  
REQUIRED



DRILLING NOT  
REQUIRED



REMOVE CONTENTS FROM BOX. VERIFY ALL PARTS ARE PRESENT.



support@trailfx.com



READ INSTRUCTIONS CAREFULLY BEFORE STARTING INSTALLATION.



1 866 638 4870

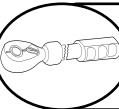

DO NOT OVER TORQUE. STANDARD OPERATING LOAD FOR TIGHTEN BODY MOUNT NUTS & BOLTS VARIES FROM 45 TO 65 FOOT POUND.



POLISHED STAINLESS STEEL - LIMITED LIFETIME  
POWDER COATED BLACK - 3 YEARS

### PARTS LIST:

Qty	Part Description	Qty	Part Description
1	Driver/Left Sidebar	4	12mm Lock Washers
1	Passenger/Right Sidebar	4	12mm Hex Nuts
2	Front Mounting Brackets	12	8-1.25mm x 25mm Hex Bolts
2	Front Support Brackets	16	8mm x 24mm x 2mm Flat Washers
1	Driver/Left Rear Mounting Bracket	12	8mm Lock Washers
1	Passenger/Right Rear Mounting Bracket	4	8mm Hex Nuts
4	14mm x 50mm x 4mm Flat Washers	8	6mm x 25mm Hex Bolts
2	12mm x 35mm Long Front Bolt Plate	16	6mm x 20mm OD x 2mm Flat Washers
2	12mm x 40mm Short Low Profile Rear Bolt Plate	8	6mm Lock Washers
4	12mm x 32mm x 3mm Flat Washers	8	6mm Hex Nuts

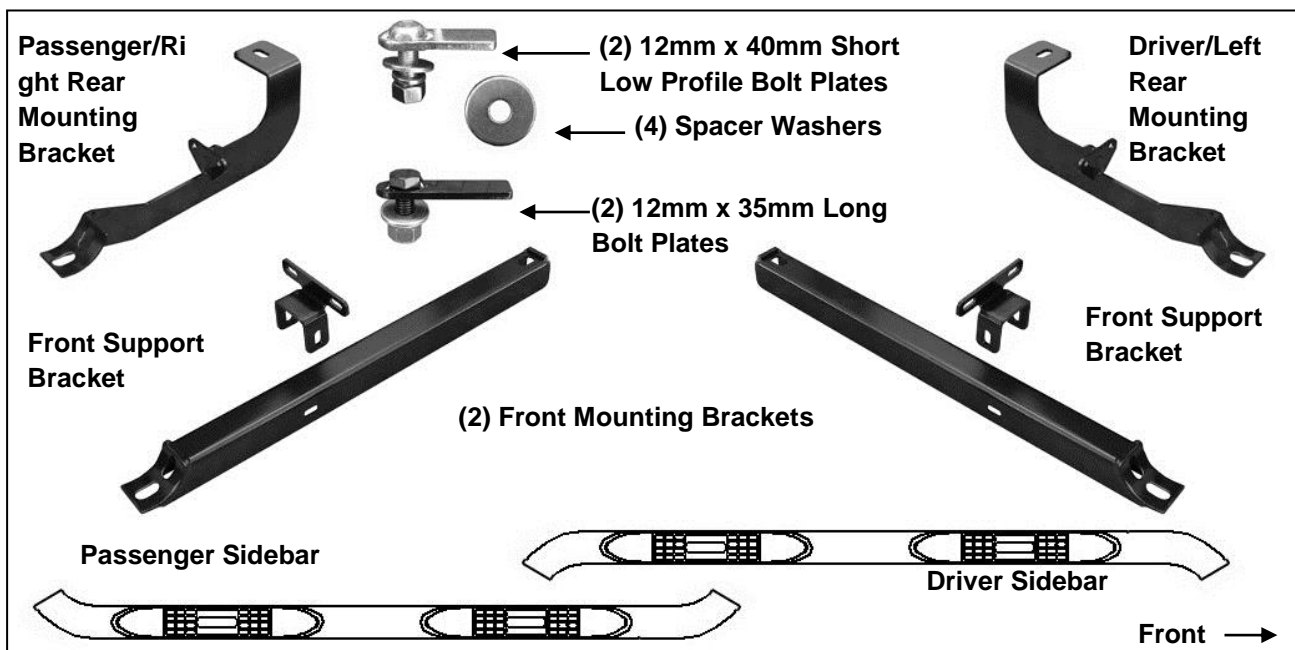

## INSTALLATION PROCEDURE

- Starting at the front, driver side of the vehicle, locate and remove the plastic cover attached to the bottom of the floor panel, **(Figure 1)**. Next, locate and remove the rubber plug in the bottom of the inner frame channel, **(Figure 2)**. Insert (1) 12mm x 35mm Long Bolt Plate into the hole, **(Figures 3A & 3B)**.

### Driver Side Installation Pictured

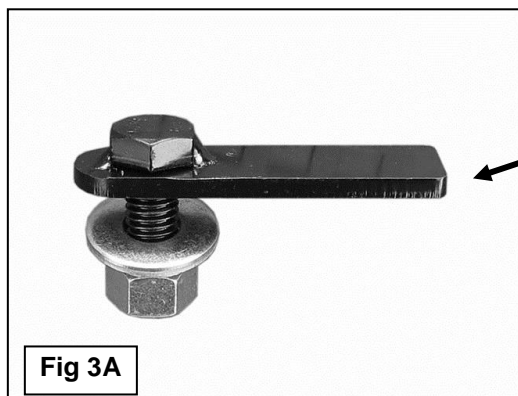
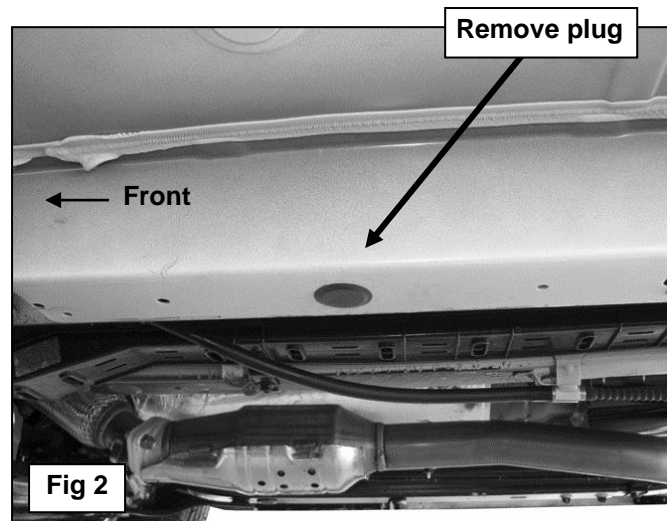
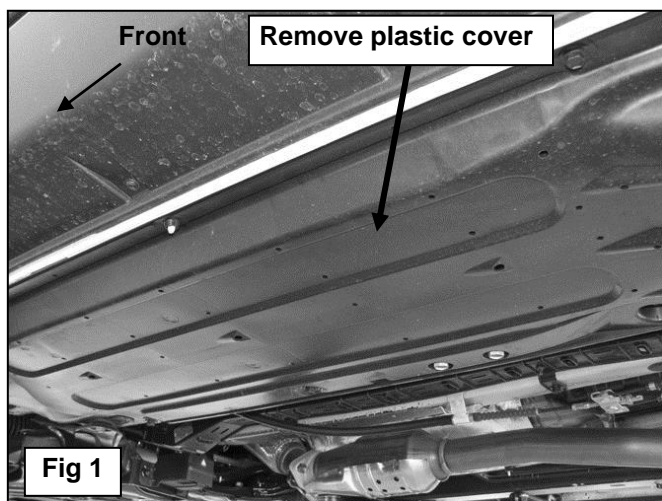

12mm x 35mm Long Bolt Plate

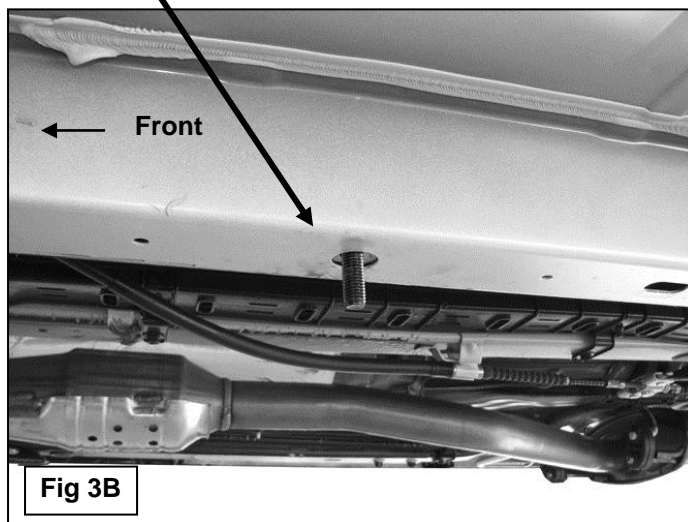

- Select (1) Front Bracket and (1) Front Support Bracket, **(Figure 4)**. Bolt the Support Bracket to the top of the front Bracket with (2) 8mm x 25mm Hex Bolts, (4) 8mm Flat Washers, (2) 8mm Lock Washers and (2) 8mm Hex Nuts. Snug but do not fully tighten hardware at this time.

- (2) 8mm x 25mm Hex Bolts
- (4) 8mm Flat Washers
- (2) 8mm Lock Washers
- (2) 8mm Hex Nuts

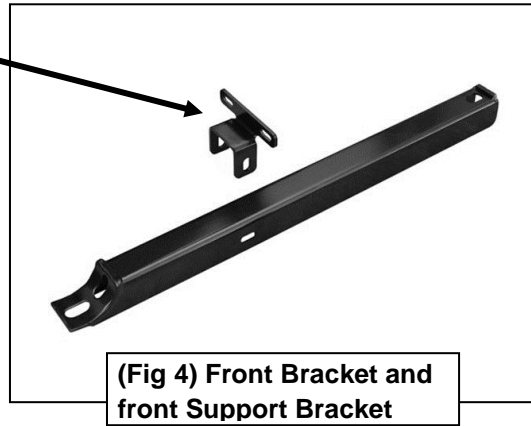

(Fig 4) Front Bracket and front Support Bracket

3. Next, attach the front Bracket assembly to the Bolt Plate with (1) 12mm Flat Washer (1) 12mm Lock Washer and (1) 12mm Hex Nut, (**Figure 5**). Leave hardware loose at this time.

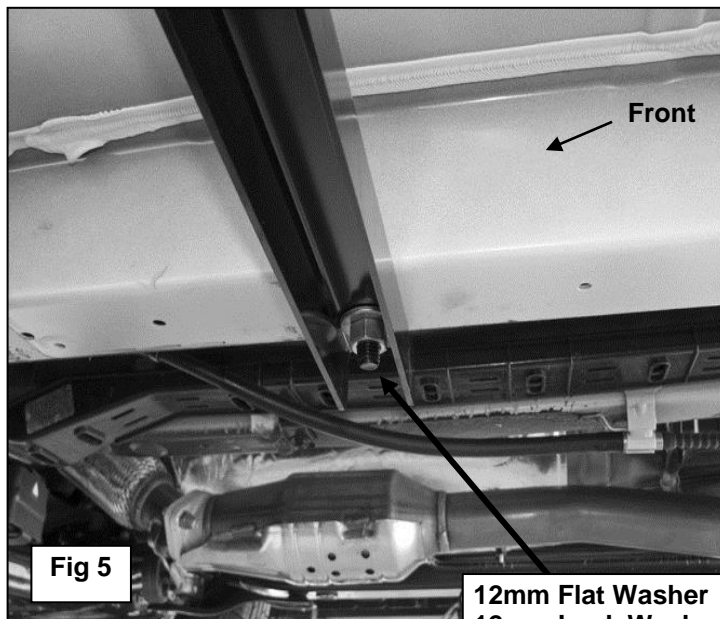

Fig 5

- 12mm Flat Washer
- 12mm Lock Washer
- 12mm Hex Nut

4. Line up the mounting tab on the front Support Bracket with the back of the pinch weld. Use a clamp to temporarily attach the Support Bracket to the pinch weld, (**Figure 6**).

Use clamp to temporarily hold front Bracket up to pinch weld until final installation

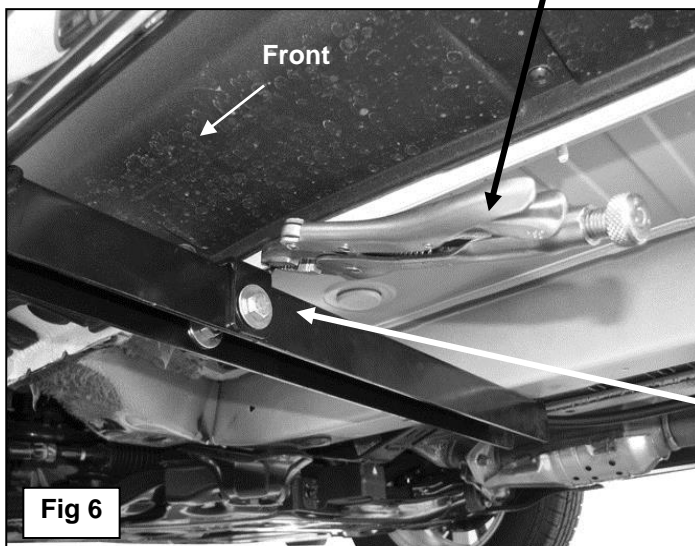
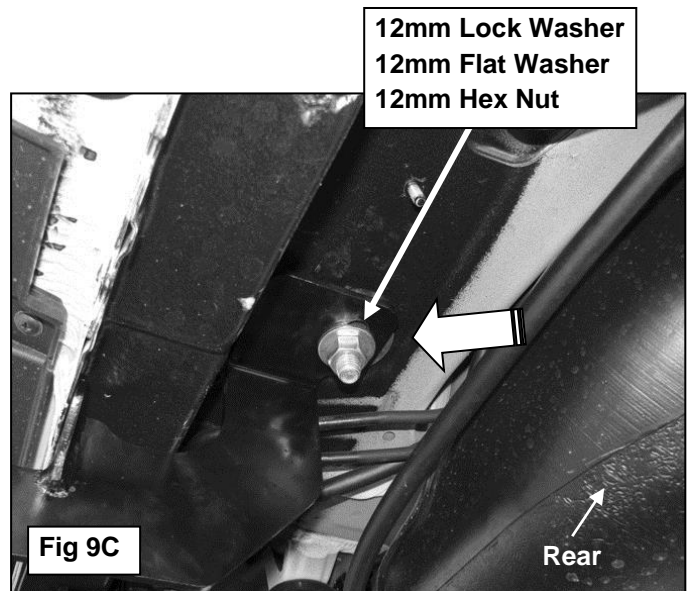
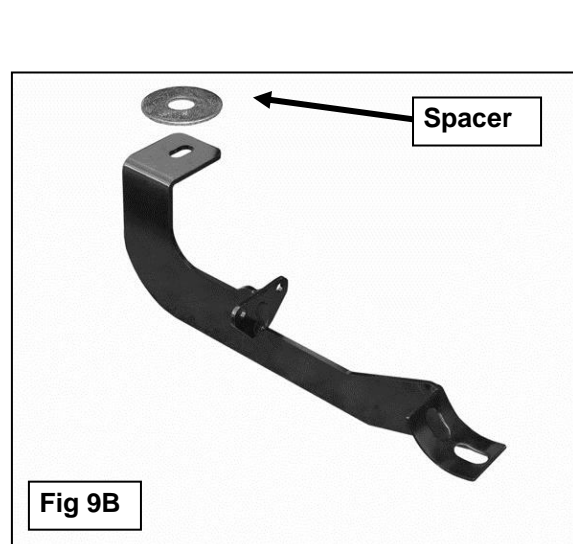
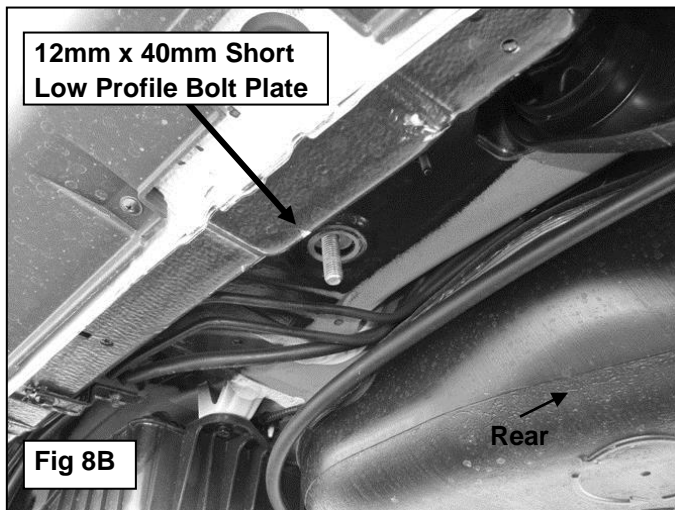
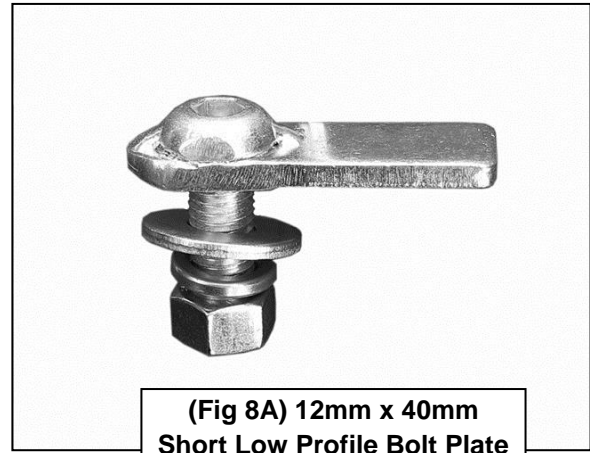
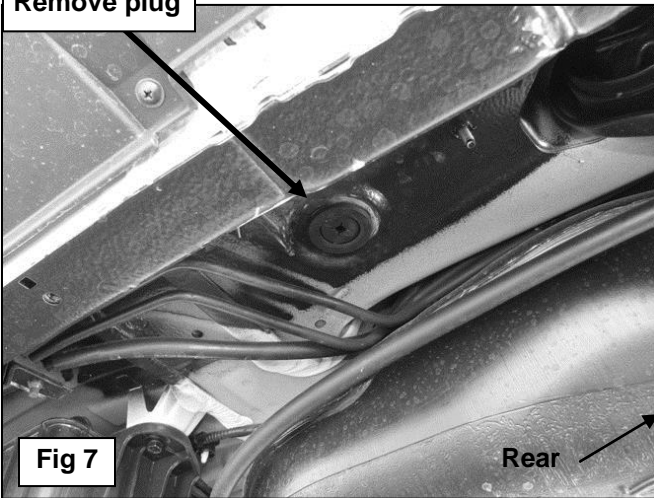

Fig 6

- (2) 8mm x 25mm Hex Bolts
- (4) 8mm Flat Washers
- (2) 8mm Lock Washers
- (2) 8mm Hex Nuts

5. Move toward the rear of the vehicle. Locate the rubber plug in the bottom of the floor panel directly in front of the rear suspension mount, **(Figure 7)**. Insert (1) 12mm x 40mm Short Low Profile Bolt Plate into the hole, **(Figures 8A & 8B)**. Slide (1) Large Spacer Washer over the Bolt Plate, **(Figure 9A & 9B)**. Attach the driver side Rear Bracket to the Spacer and Bolt Plate with (1) 12mm Flat Washer, (1) 12mm Lock Washer and (1) 12mm Hex Nut, **(Figure 9C)**.

Remove plug



Insert Spacer between the Bracket and the body panel

6. Push the mounting tab on the Bracket up against the back of the pinch weld. Use a clamp to help hold the Bracket in place if necessary. Tighten the 12mm Hex Nut only at this time. Mark the locations of the slots on the mounting tab onto the back of the pinch weld, (**Figure 12**).
7. Remove the plastic deflector in front of the rear tire, (**Figure 10**). Carefully position the driver Sidebar onto the Mounting Brackets. Attach the Sidebar to the Brackets with the included (4) 8mm x 25mm Hex Bolts, (4) 8mm Lock Washers and (4) 8mm Flat Washers, (**Figures 11 & 12**). Do not fully tighten.
8. Remove the screws attaching the plastic rocker cover to the bottom of the body, (**Figure 11**).
9. Move to the rear Bracket location. Repeat **Steps 10 & 11** to drill and attach the mounting tab on the rear Bracket to the back of the pinch weld. Reinstall and tighten the rear Bracket hardware only.

### Driver Side Installation Pictured

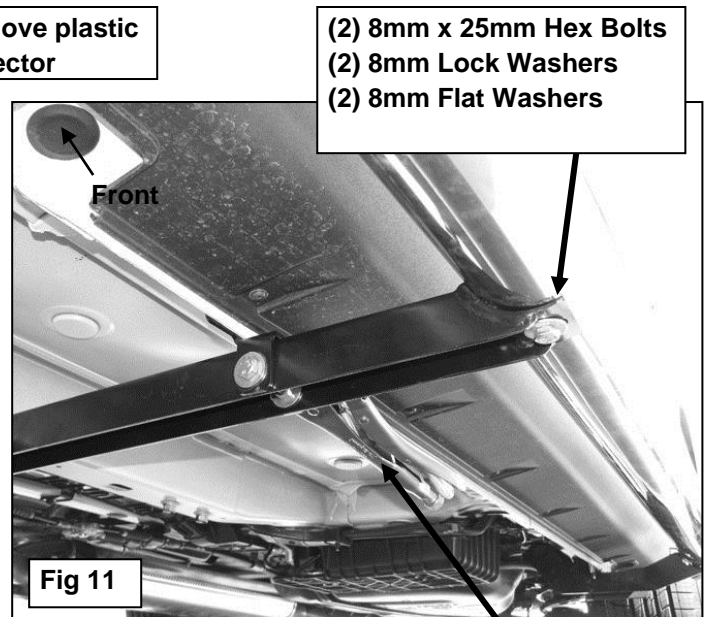
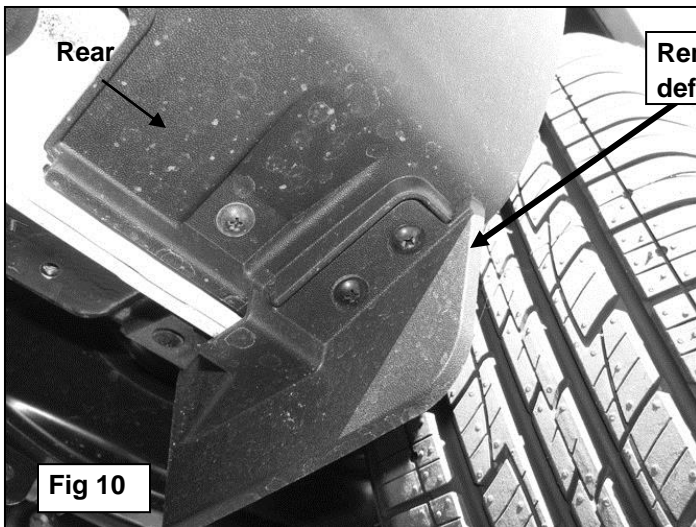

Use clamp to temporarily hold front Bracket up to pinch weld until final installation

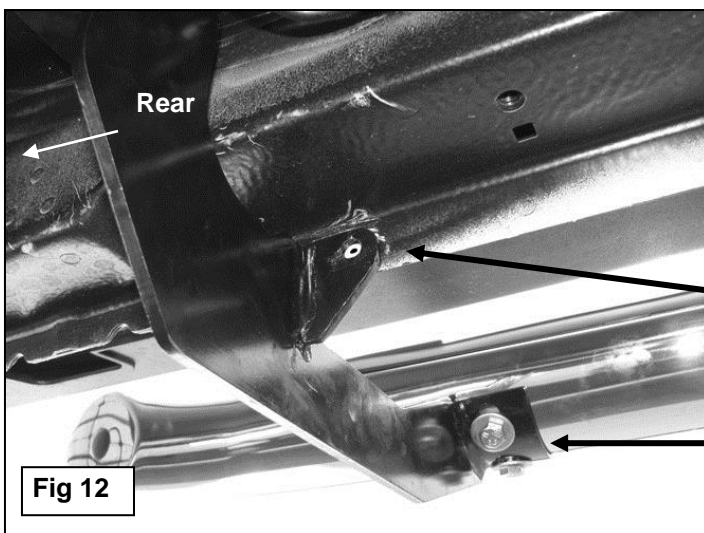



10. Level and adjust the Sidebar properly and tighten all hardware. Note that (2) extra 14mm Spacers have been included to allow for a little additional vertical adjustment as required for the front Brackets only. Insert (1) Spacer between the inner end of the front Bracket and the bottom of the frame channel over the Bolt Plate, (**Figures 13A & 13B**). **IMPORTANT:** Make sure that the Sidebar is level and that the mounting slots in the Support Bracket are not too close to the bottom edge of the pinch weld before marking any of the front or rear holes for the Brackets.

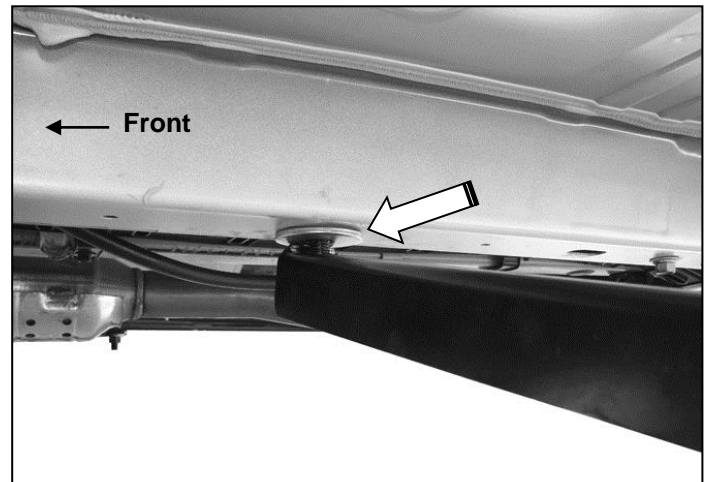
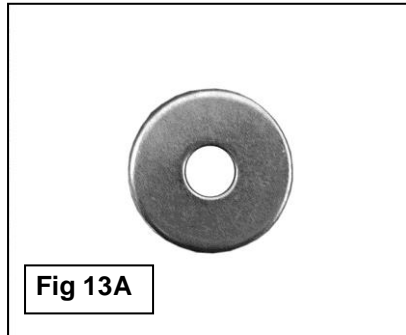

**(Fig 13B) Insert Spacer between Bracket and frame channel if additional adjustment is required**

11. Mark the front slot locations onto the back of the pinch weld, (**Figure 14**). Remove the Sidebar and the front and rear Brackets.
12. Drill (2) 1/4" holes through the pinch weld at the front Bracket location. **IMPORTANT:** Be very careful to avoid damaging the outer plastic rocker cover. Bolt the Support Bracket only to the back of the pinch weld with (2) 6mm x 25mm Hex Bolts, (4) 6mm Flat Washers, (2) 6mm Lock Washers and (2) 6mm Hex Nuts, (**Figure 15**). Snug but do not fully tighten hardware at this time.

### Driver Side Installation Pictured

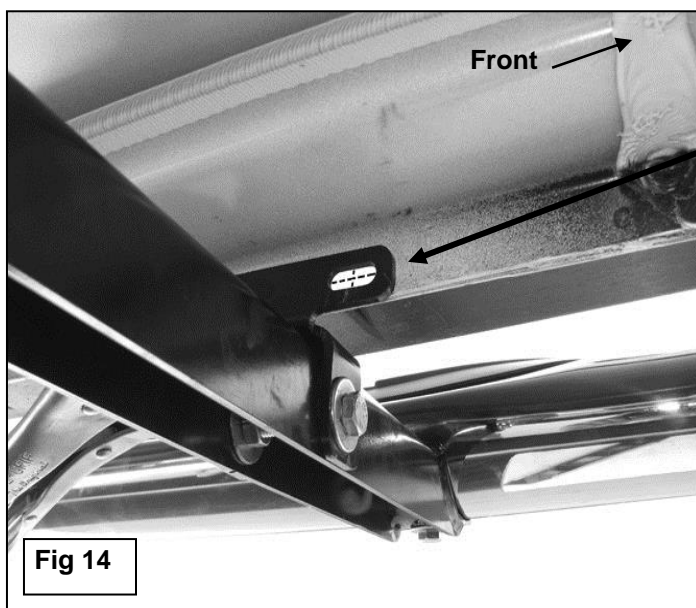

**Mark the Bracket location onto back of pinch weld. Do not drill until after Sidebar is properly aligned and adjusted. Use clamp to temporarily hold Support Bracket in place. Do not drill too close to bottom edge of pinch weld**

**(2) 6mm x 25mm Hex Bolts  
(4) 6mm Flat Washers  
(2) 6mm Lock Washers  
(2) 6mm Hex Nuts**

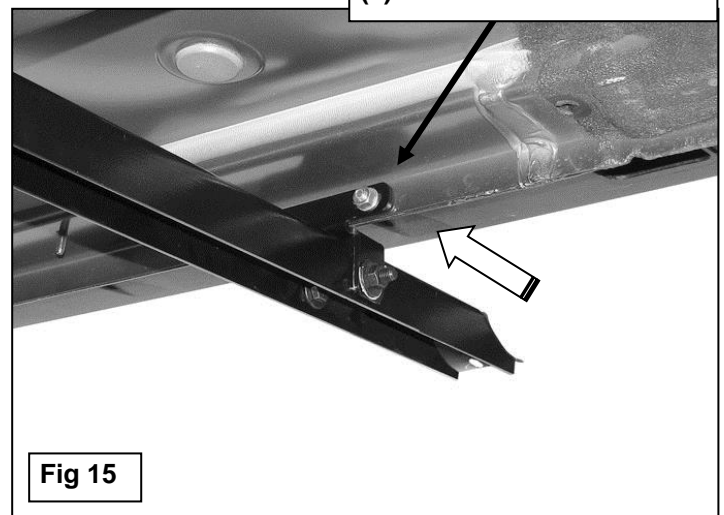

13. Reattach the rocker cover with the factory screws, (**see Step 8**). NOTE: Trim the rocker cover around the 6mm Hex Bolts for proper fit.
14. Temporarily attach the front Bracket to the front Support Bracket and Bolt Plate. Hold the large plastic cover removed in Step 2 up against the bottom of the front bracket. Mark the location of the Bracket onto the inside of the cover, (Figure 16A). Cut a slot in the cover with a sharp knife or hacksaw blade, (**Figure 16B**). IMPORTANT: Only remove material necessary to clear the front Bracket. Do not cut through the inner or outer edge of the cover. Once properly cut, remove the front Bracket. Reinstall the plastic cover with the factory hardware. Reinstall the front Bracket.
15. Reinstall the Sidebar. Align and adjust the Sidebar and fully tighten all hardware.
16. Repeat Steps 1 - 15 for passenger Sidebar installation.
17. Do periodic inspections of the installation to make sure that all hardware is secure and tight.

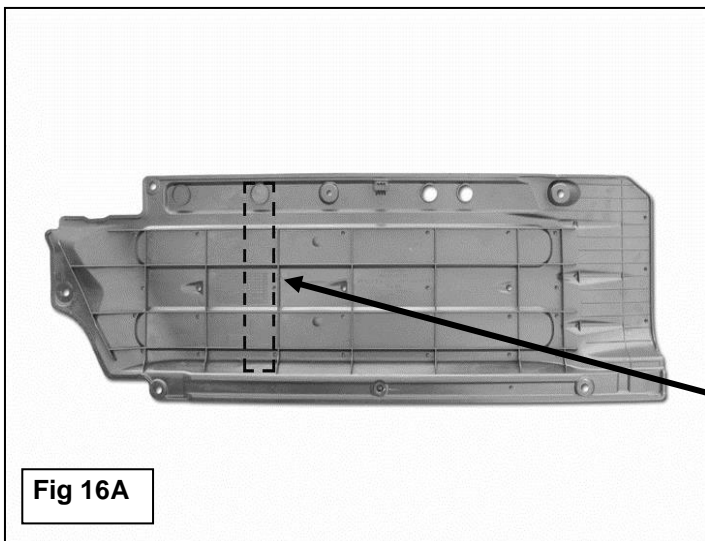

Fig 16A

After Sidebar has been properly aligned and adjusted, hold the plastic cover up in place against the front Bracket. Trace the Bracket location onto the cover. Cut slot out of cover to clear front Bracket.

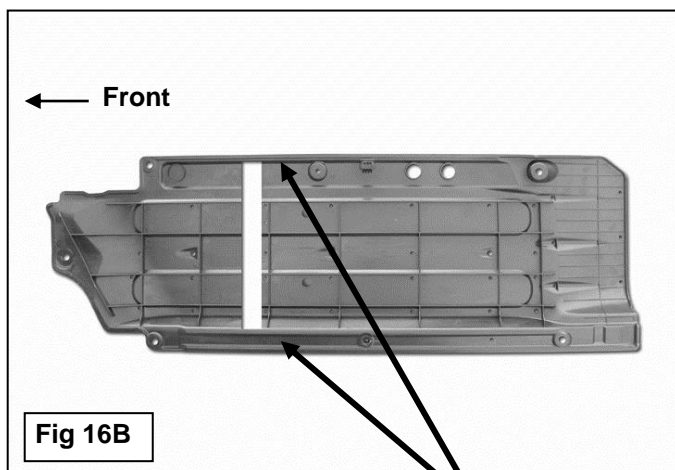

Fig 16B

**IMPORTANT:** Do not cut through the inner or outer edge of the cover. Only remove material required for Bracket clearance



Complete Installation

**PARTS IDENTIFICATION GUIDE**

*Driver Side tube packed using "Green" color foam sheet. Passenger Side tube packed using "White" color foam sheet*

No.	Parts Identification
1	Passenger / Right 'Rear' Bracket marked "PR"
2	Driver / Left 'Rear' Bracket marked "DR"
3	Passenger / Right 'Center' Bracket marked "PC"
4	Driver / Left 'Center' Bracket marked "DC"
5	Passenger / Right 'Front' Bracket marked "PF"
6	Driver / Left 'Front' Bracket marked "DF"

**Note:**

- This guide is to identify the parts and not a reference for part count.
- Product / Bracket image is for representative purpose only.
- Actual design may vary based on application.
- Refer Installation Instructions for Hardware Kit detail.

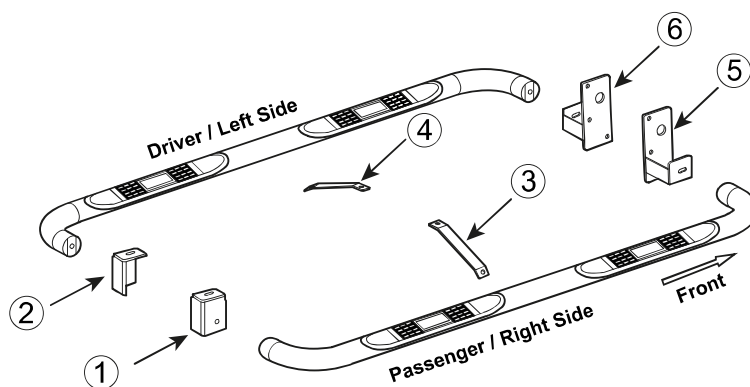
**PRODUCT CARE**

- Periodically check the product to ensure all fasteners are tight and components are intact.
- Regular waxing is recommended to protect the finish of the product.
- **Use ONLY Non-Abrasive automotive wax.** Use of any soap, polish or wax that contains an abrasive is detrimental and can scratch the finish leading to corrosion.
- Aluminum polish may be used to polish small scratches and scuffs for **Stainless Steel finish.**
- Mild soap may be used to clean the product for both **Stainless Steel and Black finish.**

**FAQ's**

1. **Hardware's are not of correct size.**  
In GMC / Chevrolet truck model 2006 & up, customer needs to reuse the factory body bolts to install the bracket. If your vehicle is not GMC / Chevrolet 2006 & up, please ensure that holes are not partially covered with any plastic grommet or rust? If it is, please remove the plastic grommet & rust from the thread holes & re-try the installation.
2. **Mounting Bracket are not getting Installed properly.**  
In some cases Illustration images shown in Installation manual may not be the exactly same as per actual vehicle images ,also if Driver / Passenger side mounting brackets are very identical in the design, suggest referring Parts Identification guide to avoid fitment issue.
3. **Products are thumping / rattling after installation.**  
Please ensure that all required mounting brackets / hardware's are installed & tighten correctly. Suggest using white lithium / regular grease between the metal to metal contact surfaces.
4. **Side Bar is not aligning with vehicle / Step Pads are not aligning with vehicle doors.**  
Side bar may be interchanged or mounting brackets are not installed at the correct position in the vehicle. Please refer Parts identification guide.
5. **Missing / Excess Hardware.**  
Recheck hardware count as per the part list.
6. **Product not installing properly.**  
Ensure make model year, cab length and bed size of your vehicle is listed in the application. All installation steps are followed correctly.

Check out these other TrailFX Products!!

www.TrailFX.com



Keystone Automotive Operations Inc. (KAO) warrants this product to be free of defects in material and workmanship at the time of purchase by the original retail consumer. KAO disclaims any other warranties, express or implied, including the warranty of fitness for a particular purpose or an intended use. If the product is found to be defective, KAO may replace or repair the product at our option, when the product is returned prepaid, with proof of purchase. Alteration to, improper installation, or misuse of this product voids the warranty. KAO's liability is limited to repair or replacement of products found to be defective, and specifically excludes liability for any incidental or consequential loss or damage.