







# 5" Oval Nerf Bar

## Part No. A7001S /B



**Fits:** 1999-2013 Chevrolet Silverado 1500/2500LD Reg. Cab  
 2001-2014 Chevrolet Silverado 2500HD/3500 Reg. Cab  
 1999-2013 GMC Sierra 1500/2500LD Reg. CAB  
 2001-2014 GMC Sierra 2500HD/3500 REG. CAB

-  Excl. C/K "Classic"
-  REMOVE CONTENTS FROM BOX. VERIFY ALL PARTS ARE PRESENT.
-  READ INSTRUCTIONS CAREFULLY BEFORE STARTING INSTALLATION.
-  DO NOT OVER TORQUE. STANDARD OPERATING LOAD FOR TIGHTEN BODY MOUNT NUTS & BOLTS VARIES FROM 45 TO 65 FOOT POUND.



60-180 min



Cutting Not Required



Drilling Not Required

 [support@trailfx.com](mailto:support@trailfx.com)

 1 866 638 4870

 **WARRANTY** POLISHED STAINLESS STEEL – LIMITED LIFETIME  
POWDER COATED BLACK – 3 YEARS

### PARTS LIST:

Qty	Part Description	Qty	Part Description
1	Driver/Left Sidebar	2	10mm Nut Plates
1	Passenger/Right Sidebar	4	10-1.50mm x 30mm Hex Bolts
1	Driver/Left Front Mounting Bracket	6	10mm x 20mm OD x 2mm Flat Washers
1	Passenger/Right Front Mounting Bracket	4	10mm Lock Washers
1	Driver/Left Rear Mounting Bracket	2	10mm Hex Nuts
1	Passenger/Right Rear Mounting Bracket	8	8-1.25 x 25mm Hex Bolts
1	Driver/Left Front Support Bracket	8	8mm x 24mm x 2mm Flat Washers
1	Passenger/Right Front Support Bracket	8	8mm Lock Washers

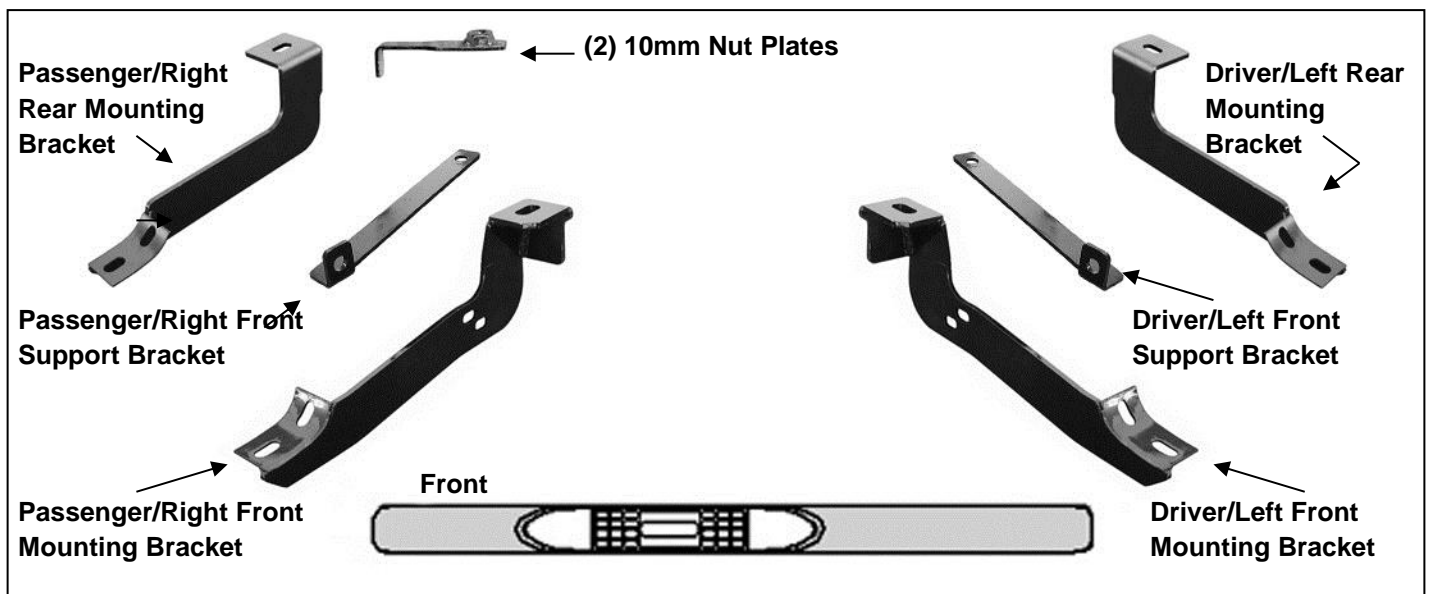

**IMPORTANT ALERT:** GM uses a very strong thread-locking compound on all body bolts. Use of an air assisted impact ratchet can cause damage to the threads on factory body mount bolts and the internal nut assembly because of this thread locking compound.

We only recommend the use of hand tools to slowly remove and reinstall body mount bolts on all GM vehicles.

#### INSTALLATION PROCEDURE:

**CRITICAL INFORMATION:** If during the removal process, it becomes increasingly difficult to unscrew the body mount bolt with hand tools, tighten the bolt several rotations to clear the thread locking compound from the threads, then reverse direction and continue to unscrew until the body mount bolt is out. Repeat this process as necessary on all GM body mount bolts. Use of an appropriate anti-seize compound is highly recommended for re-installation. Tighten body mount bolt to factory torque specifications for your particular model year.

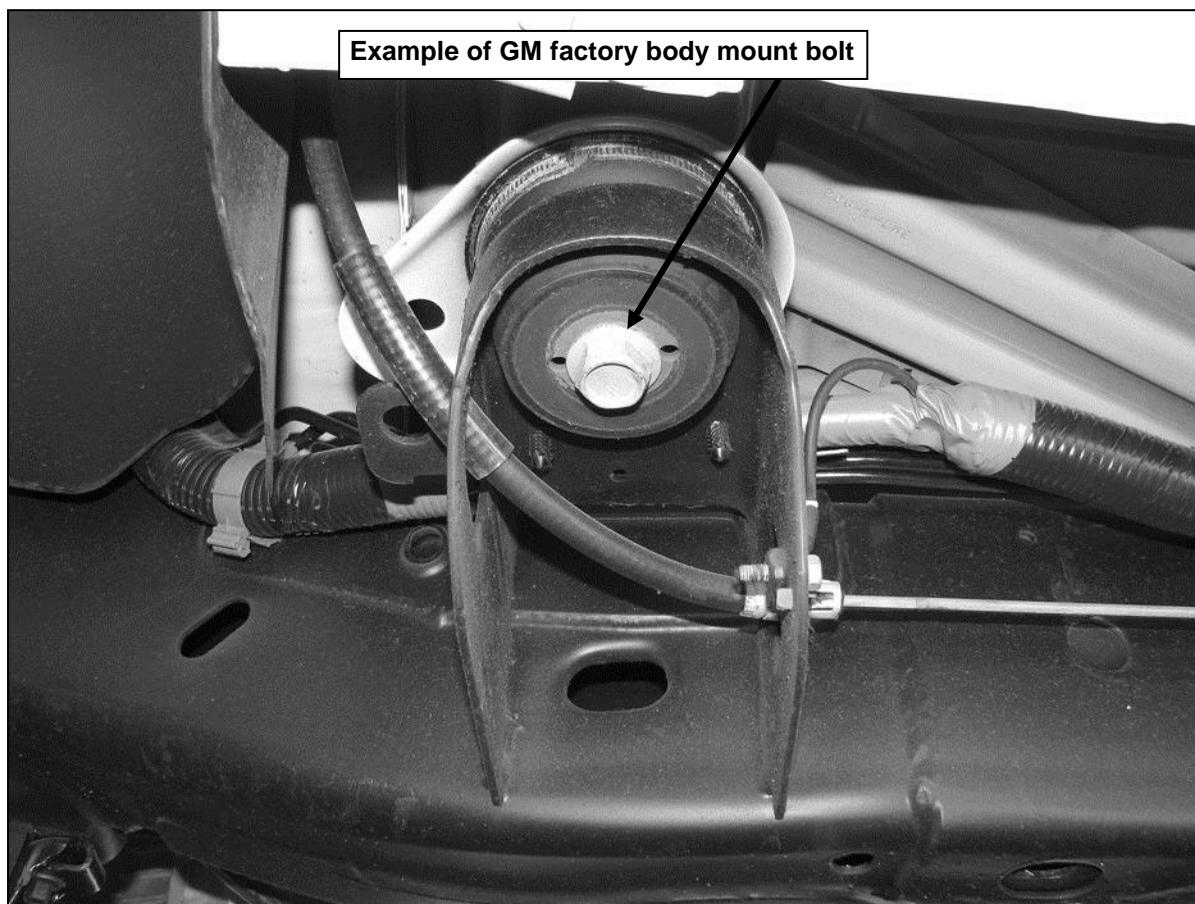

**INSTALLATION PROCEDURE:**

1. Start the installation under the driver side of the vehicle and remove the front and rear body mount bolts. Do not remove bushings
2. Hang the driver side front and rear Mounting Brackets from the body mounts using the factory hex bolts, **(Figures 1 & 2)**. Do not tighten hardware at this time.

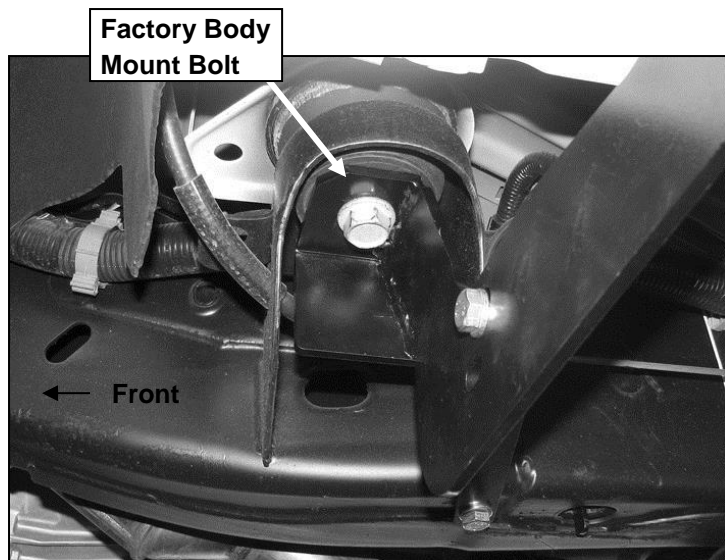
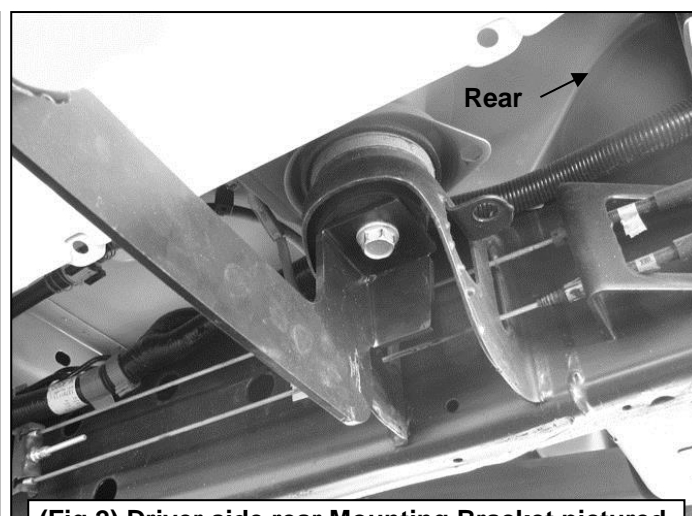
**(Fig 1) Driver side front Mounting Bracket pictured****(Fig 2) Driver side rear Mounting Bracket pictured**

3. Locate the two factory holes in the bottom of the frame towards the front of the vehicle. Insert (1) 10mm Nut Plate, **(Figure 3A)**, into the oval hole and line up the threaded nut with the forward round hole, **(Figure 3B)**.

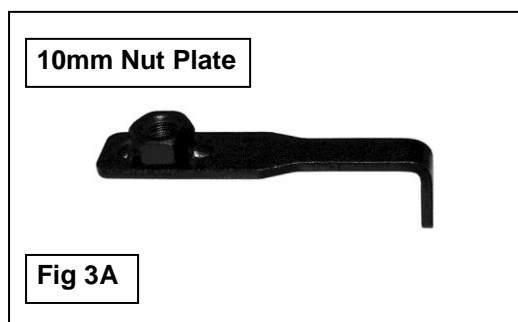
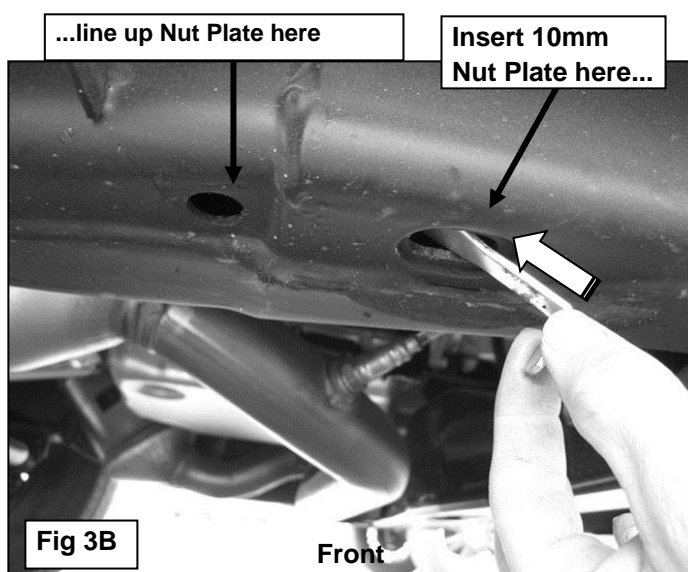
**10mm Nut Plate****Fig 3A****Fig 3B****Front**

4. Attach the driver side front Support Bracket to the Nut Plate with (1) 10mm x 30mm Hex Bolt, (1) 10mm Lock Washer and (1) 10mm Flat Washer, **(Figures 4 & 5)**. Do not tighten hardware at this time.

**1500 Models:**

Attach the bent end of the Front Support Bracket to the outside hole in the Front Mounting Bracket with (1) 10mm x 30mm Hex Bolt, (2) 10mm Flat Washers, (1) 10mm Lock Washer and (1) 10mm Hex Nut, **(Figure 4)**. Do not tighten at this time.

**Up to 2010 25-3500 Models:**

Note that the Front Support Bracket will not reach up to the Mounting Bracket, **(Figure 5)**. Tighten the Support Bracket to the Nut Plate in the frame. Carefully push up on the Support Bracket until it reaches the lower/inside hole in the Mounting Bracket. Bolt the Support Bracket to the hole in the Mounting Bracket with (1) 10mm x 30mm Hex Bolt, (2) 10mm Flat Washers, (1) 10mm Lock Washer and (1) 10mm Hex Nut, **(Figure 4)**. Do not tighten at this time.

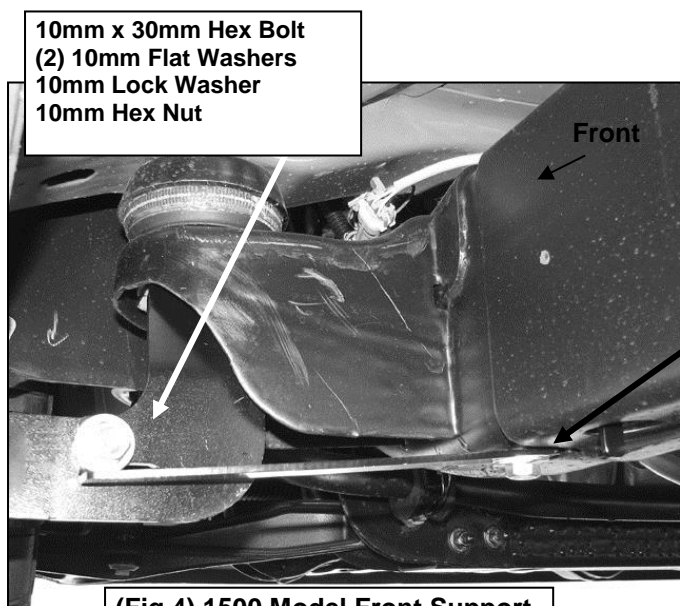

10mm x 30mm Hex Bolt  
 (2) 10mm Flat Washers  
 10mm Lock Washer  
 10mm Hex Nut

10mm Nut Plate  
 10mm x 30mm Hex Bolt  
 10mm Lock Washer  
 10mm Flat Washer

(Fig 4) 1500 Model Front Support Bracket Installation Pictured

**IMPORTANT NOTE:** Up to 2010 25-3500 Model Front Support Bracket Installation Pictured. Bend Support Bracket up by hand to meet the Front Mounting Bracket. Front Support Bracket not required for 2011-12 25-3500 models

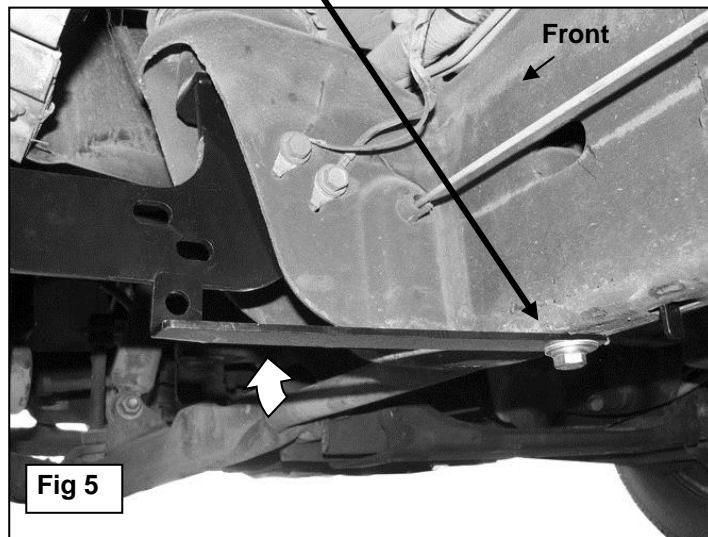
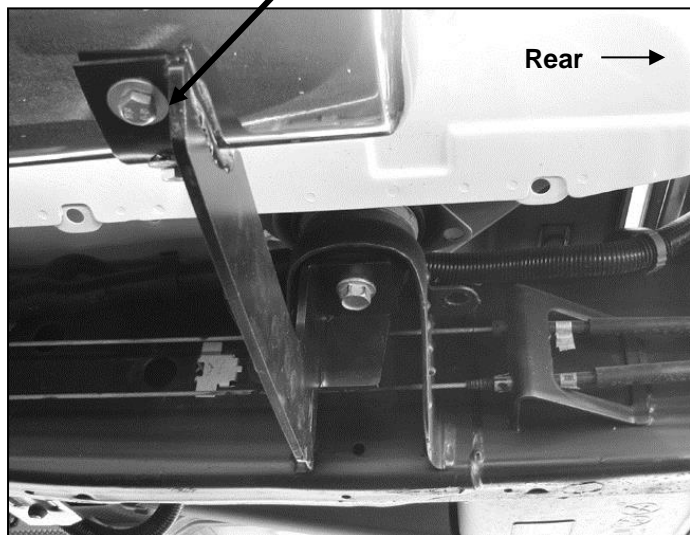

Fig 5

5. Carefully position the Driver Sidebar onto the Mounting Brackets. Attach the Sidebar to the Mounting Brackets with (4) 8mm x 25mm Hex Bolts, (4) 8mm Lock Washers and (4) 8mm Flat Washers, (Figure 6). Do not tighten hardware at this time.
6. Level and adjust the Sidebar and tighten all hardware.
7. Repeat steps 2-6 for passenger Sidebar installation.
8. Do periodic inspections to the installation to make sure that all hardware is secure and tight.

(2) 8mm x 25mm Hex Bolts  
 (2) 8mm Lock Washers  
 (2) 8mm Flat Washers



(Fig 6) Driver side rear Bracket installation pictured



Complete Installation

**PARTS IDENTIFICATION GUIDE**

**Driver Side tube packed using "Green" color foam sheet. Passenger Side tube packed using "White" color foam sheet**

No.	Parts Identification
1	Passenger / Right 'Rear' Bracket marked "PR"
2	Driver / Left 'Rear' Bracket marked "DR"
3	Passenger / Right 'Center' Bracket marked "PC"
4	Driver / Left 'Center' Bracket marked "DC"
5	Passenger / Right 'Front' Bracket marked "PF"
6	Driver / Left 'Front' Bracket marked "DF"

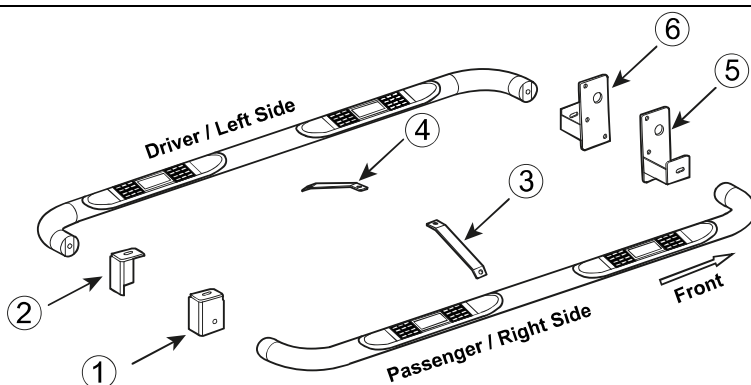
**Note:**

- This guide is to identify the parts and not a reference for part count.
- For part count, refer Parts List.
- Product / Bracket image is representative and actual design may vary.

**PRODUCT CARE**

- Periodically check the product to ensure all fasteners are tight and components are intact.
- Regular waxing is recommended to protect the finish of the product.
- **Use ONLY Non-Abrasive automotive wax.** Use of any soap, polish or wax that contains an abrasive is detrimental and can scratch the finish leading to corrosion.
- Aluminum polish may be used to polish small scratches and scuffs for **Stainless Steel finish.**
- Mild soap may be used to clean the product for both **Stainless Steel and Black finish.**

**FAQ's****1. Hardware's are not of correct size.**

*In GMC / Chevrolet truck model 2006 & up, customer needs to reuse the factory body bolts to install the bracket. If your vehicle is not GMC / Chevrolet 2006 & up, ensure that holes are not partially covered with any plastic grommet or rust? If it is, remove the plastic grommet & rust from the thread holes & re-try the installation.*

**2. Mounting Bracket are not getting Installed properly.**

*In some cases Illustration images shown in Installation manual may not be the exactly same as per actual vehicle images ,also if Driver / Passenger side mounting brackets are very identical in the design, suggest referring Parts Identification guide to avoid fitment issue.*

**3. Products are thumping / rattling after installation.**

*Ensure that all required mounting brackets / hardware's are installed & tighten correctly. Suggest using white lithium / regular grease between the metal to metal contact surfaces.*

**4. Side Bar is not aligning with vehicle / Step Pads are not aligning with vehicle doors.**

*Side bar may be interchanged or mounting brackets are not installed at the correct position in the vehicle. Refer Parts identification guide.*

**5. Missing / Excess Hardware.**

*Recheck hardware count as per the part list.*

**6. Product not installing properly.**

*Ensure make model year, cab length and bed size of your vehicle is listed in the application. All installation steps are followed correctly.*

**Check out these other TrailFX Products!!**

[www.TrailFX.com](http://www.TrailFX.com)



**BULL BAR**



**GRILLE GUARDS**



**BED RAILS**



**RUNNING BOARDS**

Keystone Automotive Operations Inc. (KAO) warrants this product to be free of defects in material and workmanship at the time of purchase by the original retail consumer. KAO disclaims any other warranties, express or implied, including the warranty of fitness for a particular purpose or an intended use. If the product is found to be defective, KAO may replace or repair the product at our option, when the product is returned prepaid, with proof of purchase. Alteration to, improper installation, or misuse of this product voids the warranty. KAO's liability is limited to repair or replacement of products found to be defective, and specifically excludes liability for any incidental or consequential loss or damage.